

SPECIAL SELECTION TEST

Held: 12 April 1975

**TO SELECT TECHNICAN STAFF FOR TRAINING LEADING TO ELIGIBILITY FOR
PROMOTION AS TELECOMMUNICATIONS TECHNICAL OFFICER IN
THE POSTMASTER-GENERAL'S DEPARTMENT**

Paper No. 1

(9.00 a.m. - 11.10 a.m.)

TELECOMMUNICATIONS PRINCIPLES

Time allowed: two hours

Perusal time: ten minutes

Maximum marks: 100

Pass Conditions:

Minimum mark: 40

Combined mark for Papers 1 & 2: 100

INSTRUCTIONS TO CANDIDATES

1. Write your distinguishing number at the top of the front cover of the answer book provided.
2. This examination paper contains ten questions. **ATTEMPT SIX QUESTIONS ONLY. QUESTIONS 1 & 2 ARE COMPULSORY.** Answer any four from the other eight.
3. Write your answer in the answer book provided and hand it in; **DO NOT TEAR OUT ANY PAGES.**
4. Do all rough working on the blank left hand pages of the answer book.
5. Clarity in setting out the key steps in solutions to problems will be taken into account when allotting marks.
6. Question 1 is worth 20 marks. All other questions are of equal value at 16 marks each.
7. Mathematical tables are provided. Slide rules may be used.

Q.1 Two parallel resistors of 240 and 480 ohms are connected in series with an unknown resistor to a 48 volt battery. A switch is wired in parallel with the unknown resistor. When the switch is closed, the current in the 240 ohm resistor is 180 mA. When the switch is opened, the power used by the 480 ohm resistor is 192 mW.

- (a) Calculate the internal resistance of the battery. (6 marks)
- (b) Calculate the value of the unknown resistance. (6 marks)
- (c) Determine the P.D. across the unknown resistor when the switch is closed. (2 marks)
- (d) A double coil relay has its second coil short circuited by one of its own break contacts as shown in the circuit below. Explain the effect that this contact and winding have on the operate and release times of the relay.

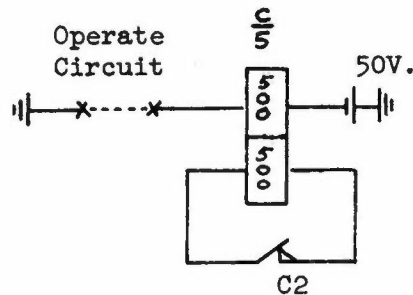

(6 marks)

Q.2 When a resistance and inductance are connected in series across a 48 volt 800 Hz supply, the current is 240 mA at a power factor of 0.6 lagging. Calculate the current and power factor when the same components are connected in parallel across the same supply.

(16 marks)

Q.3 (a) In the circuit below, the generator has an output impedance of 60,000 ohms and an adjustable output voltage. The transformer T is chosen to match the generator to the 600 ohm line, and the O/P voltage is adjusted such that the power delivered to the line is 0 dbm.

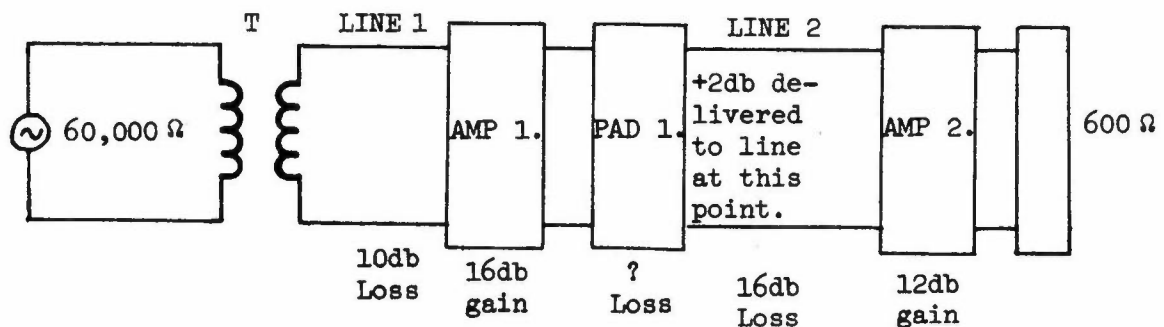

- Calculate
- (i) The turns ratio of transformer T and the voltage at the primary of the transformer. (4 marks)
- (ii) The loss in pad 1. (1 mark)
- (iii) The power, expressed in milliwatts, delivered to the 600 ohm termination. (4 marks)

- (b) If transformer T was replaced with one having a different turns ratio, what would be the effect on the power delivered to the load. (3 marks)
- (c) With the aid of sketches, explain why it is necessary to use attenuation equalisers with transmission lines. (4 marks)

Q.4 (a) A standard frequency of 1 kHz is applied to the horizontal deflecting plates of a cathode ray oscilloscope and unknown frequencies are applied, in turn, to the vertical deflecting plates. The patterns shown below are obtained.

What is the frequency in each case?

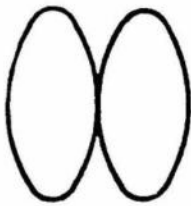

(i)

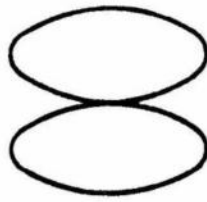

(ii)

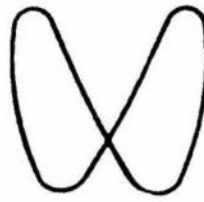

(iii)

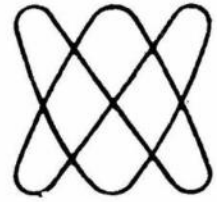

(iv)

(4 marks)

- (b) A moving coil meter has a F.S.D. of 100 microamps and an internal resistance of 100 ohms.

Draw circuit diagrams of the connections which enable the meter to have a full-scale reading of

(i) 10 Volts

(ii) 50 milliamps

and calculate the values of the additional components required.

(8 marks)

- (c) What changes to the circuit of the meter would be required to enable it to measure A.C. voltage? (4 marks)

Q.5 (a) The circuit below is used as a preamplifier for a high impedance microphone.

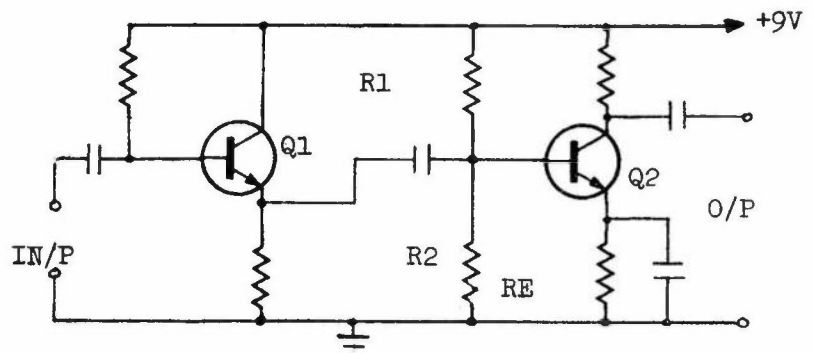

- (i) What feature of the circuit configuration used for Q1. makes it particularly suitable for the application? (2 marks)
- (ii) Why is there no bypass capacitor across the emitter resistor of Q1? (2 marks)
- (iii) Briefly explain how the bias arrangement for Q2 operates.

(4 marks)

- (b) Briefly explain the operation of the phase-shift oscillator shown. Include reference to the components which control the frequency of the oscillator.

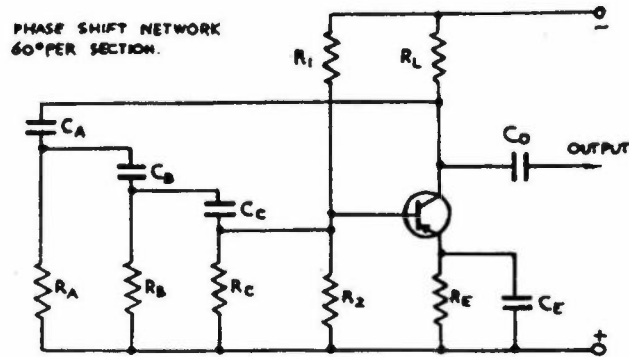

(8 marks)

- Q.6 (a) Transistor amplifiers can be operated in three main classes. Label the diagrams to indicate the class that each diagram represents and draw the output signal for the input cycle shown in each diagram.

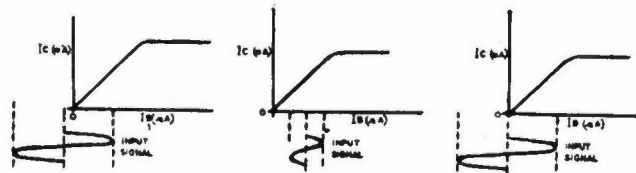

See attached answer sheet.

(4 marks)

- (b) Briefly explain the operation of each class of amplifier, giving examples where each would be used. (6 marks)

- (c) (i) In the tuned circuit below, calculate the resonant frequency. (4 marks)

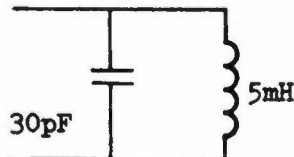

(4 marks)

- (ii) If the capacitance is increased, what is the effect on the resonant frequency. (2 marks)

- Q.7 In the circuit a time delay is introduced in the operation of the relay. The switch rests in position 1 and timing starts when the switch is operated to position 2. The relay operates when the grid potential is -10 volts and releases when the grid potential is -15 volts, with respect to the cathode in each case. Calculate the value of the capacitor to give a 4.6 minute delay. (16 marks)

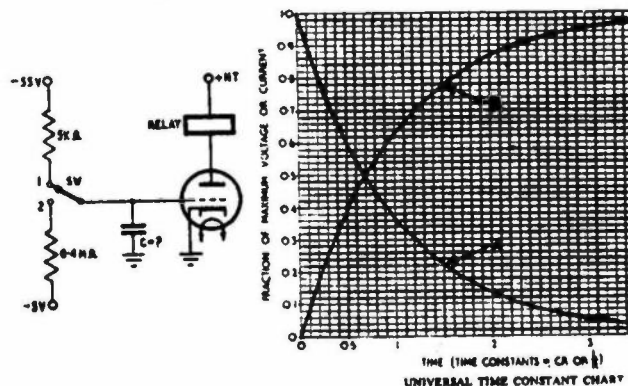

(16 marks)

- Q.8 (a) Describe with the aid of a diagram, how a Wheatstone bridge circuit can be used to measure resistance. (5 marks)

(b)

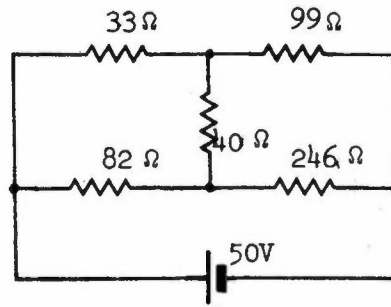

- (i) In the circuit above, calculate the current in the 40 ohm resistor, if the battery has negligible internal resistance. (3 marks)
- (ii) If the battery is replaced by one having an internal resistance of 10 ohms, what is now the current in the 40 ohm resistor. (2 marks)
- (c) The term 'Astable' applied to a multivibrator indicates a continuing output without external triggering. Briefly explain what is meant by the terms 'Bistable' and 'Monostable'. (6 marks)

- Q.9 The circuit below shows a phase inverter stage using a twin triode electron tube. It is operated from a 200 volt H.T. supply and the anode current in each tube is 0.85 mA.

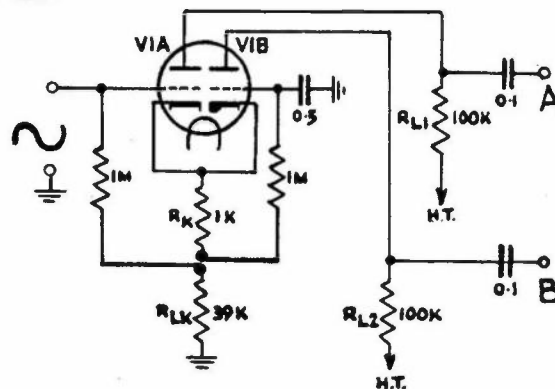

- (a) State a typical use for this type of circuit and show the waveforms at points A and B with respect to earth for the input signal shown. (4 marks)
- (b) Calculate the anode voltage of V1B with respect to cathode. (6 marks)
- (c) Explain how bias is applied to V1A and determine its value. (6 marks)

Q.10 (a) How are semiconductor diode elements grouped to increase (i) the overall voltage rating (ii) the overall current rating of a rectifier. (4 marks)

(b) Explain the operation of the rectifier circuits illustrated.

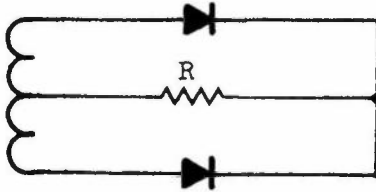

(i) Push-pull

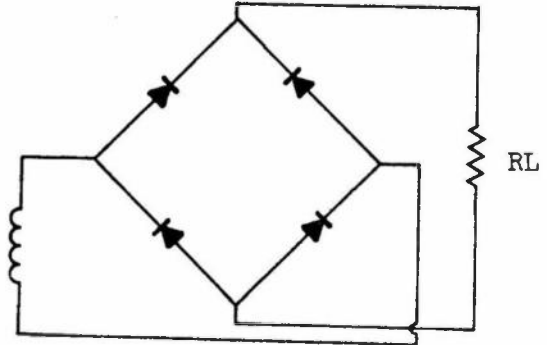

(ii) Bridge

What are the advantages of the bridge circuit? (6 marks)

(c) Sketch a full wave voltage double rectifier circuit and describe its operation.

What is its main disadvantage? (6 marks)