

THE POST OFFICE ELECTRICAL ENGINEERS' JOURNAL

Vol. 46

APRIL 1953

Part 1

CONTENTS

	PAGE
SATELLITE EXCHANGE WORKING IN NON-DIRECTOR MULTI-EXCHANGE SYSTEMS —W. J. E. Tobin, B.Sc., A.C.G.I., D.I.C., A.M.I.E.E., and S. Birch, A.M.I.E.E.	1
SIGNALLING SYSTEM A.C. NO. 5X—G. Toft	7
A NEW CABLE-FAULT INDICATOR—M. B. Williams, B.Sc.(Eng.), A.M.I.E.E., and D. Brookes, Graduate I.E.E.	13
SINGLE-SIDEBAND MULTI-CHANNEL OPERATION OF SHORT-WAVE POINT-TO- POINT RADIO LINKS, Part 3—An Independent-Sideband Short-Wave Radio Receiver— W. R. H. Lowry, B.Sc., and W. N. Genna	19
TELEGRAPH POWER PLANT USING A D.C. ASTATIC RELAY FOR VOLTAGE CONTROL—R. E. Hill, Graduate I.E.E.	25
A PARTIAL CALL QUEUEING SCHEME FOR SLEEVE-CONTROL EXCHANGES..	29
THE PACKAGING OF TELEPHONE EXCHANGE EQUIPMENT FOR LONG-TERM STORAGE IN TEMPERATE CLIMATES—G. W. Mackie and J. L. Cunningham, Associate I.E.E.	30
INTER-OFFICE TELEPHONE SYSTEM FOR THE POSTMASTER-GENERAL	33
THERMISTOR PRODUCTION—W. T. Gibson, O.B.E., M.A., B.Sc., M.I.E.E.	34
THE USE OF DRY CELLS IN SUBSCRIBERS' PREMISES—R. Collings and F. G. Jackson	37
NOTES AND COMMENTS	39
INSTITUTION OF POST OFFICE ELECTRICAL ENGINEERS	39
REGIONAL NOTES	40
ASSOCIATE SECTION NOTES	47
STAFF CHANGES	50
BOOK REVIEWS	6, 12, 18, 36, 38, 49

Price 2/6 net

How to make certain of your City & Guilds Certificates



"I guarantee tuition until you have passed"

If you consider taking one or the whole series of C. and G. examinations then I can help you. BY POST, in your own time, one of my Telecommunications specialists will coach you until you pass. He will give you individual attention, he will study you and your problems. And you will be surprised how fast you progress. For The Bennett College has specialised in technical subjects since it was founded 50 years ago. My system of personal postal tuition has helped thousands of students through their exams. It can do the same for you.

Send me the coupon to-day. I will send you—without obligation—full information on your subject.

Rep Bennett
GOVERNOR

YOU CAN START ON A BENNETT COURSE FOR ONLY 30/-

TEAR OUT

with monthly instalments of 15/-

WHICH IS YOUR NEXT STEP?

Preliminary Course
Telecommunications Principles I—V
Telecommunications Practice
Telephone Exchange Systems I—III

Radio I—IV
Telegraphy I & II
Line Transmission I & II
Mathematics for Telecommunications I—V

Radio Servicing Certificate
Television Servicing Certificate
A.M.I. Mech.E.
and many other subjects

The BENNETT COLLEGE

To the Governor, Dept. D24, The Bennett College, Sheffield, England. I would like to have (at no cost) your prospectus on:

NAME

ADDRESS

AGE (if under 21)

PLEASE WRITE IN BLOCK LETTERS.

ANACOS

REGD.

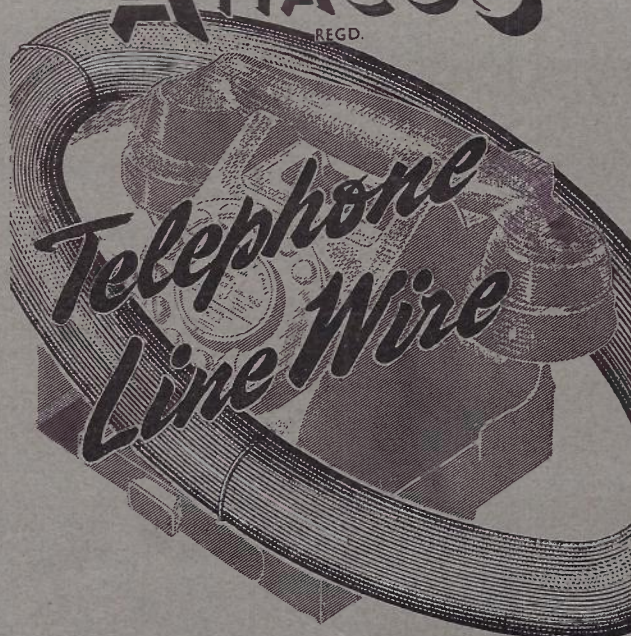

FOR THE RIGHT CONNECTION

FREDERICK SMITH & COMPANY
ANACONDA WORKS, SALFORD, 3, LANCS.

Incorporated in The London Electric Wire Company and Smiths Limited
Associated with The Liverpool Electric Cable Co. Ltd and Vesta Wire Co. Ltd



PROTECTION UNDER WATER!

The pipe in the photograph is one of many which have been Denso-protected prior to placing under water—in this instance Lake Zurich. Of a diameter of 350 mm., individual lengths of 50-60 metres were assembled on the bank, floated into position and sunk.

Necessary joints were made by a diver and then Denso-protected. The photograph shows the Denso tape actually being applied. Whether used under water, below or above ground, Denso—an anti-corrosive of proved ability—provides a protection which is full and lasting. Its "cold" application greatly reduces time and labour costs—an important consideration!

VISIT OUR STAND
D150, BIF,
CASTLE BROMWICH,
BIRMINGHAM



WINN & COALES LIMITED

DENSO HOUSE, CHAPEL ROAD, LONDON, S.E.27

Telephone: GIPsy Hill 4247/8. Telegrams: Denselte, Westnor, London.

FREE THIS VALUABLE BOOK



which details the wide range of Engineering and Commercial courses of modern training offered by E.M.I. Institutes—the only Postal College which is part of a world-wide Industrial Organisation.

Courses include training for:

P.M.G. Certificates, City and Guilds Grouped Certificates in Telecommunications; A.M.Brit.I.R.E. Examination, Radio Amateur's Licence, Radio & Television Servicing Certificates, General Radio and Television Courses, Radar, Sound Recording, etc. Also Courses in all other branches of Engineering.

E.M.I.

Institutes
associated with
MARCONIPHONE
COLUMBIA

H.M.V.
(His Master's Voice)
ETC.

COURSES FROM

£1

PER MONTH

POST NOW

Please send, without obligation, the above FREE book. E.M.I. Institutes, Dept. 22, 43 Grove Park Road, London, W.4.

Subject(s) which interest me

Name

Address

IC 10e

THE POST OFFICE

ELECTRICAL ENGINEERS' JOURNAL

Vol. 46

April 1953

Part 1

Satellite Exchange Working in Non-Director Multi-Exchange Systems

W. J. E. TOBIN, B.Sc., A.C.G.I., D.I.C., A.M.I.E.E.
and S. BIRCH, A.M.I.E.E.†

U.D.C. 621.395.743: 621.395.347.2.

The present B.P.O. standard equipment for satellite exchanges in non-director multi-exchange areas includes digit absorption and discrimination features for routing calls within a linked numbering scheme. The authors discuss a number of possible alternatives to this arrangement and describe a particular alternative using 2000-type group selector satellite equipment without digit absorption or discrimination. It is shown that such a scheme is attractive on economic grounds and has certain other inherent advantages.

INTRODUCTION

MULTI-EXCHANGE systems are designed to serve a city or large town where, although more than one exchange is necessary for an economic layout of plant, the telephone community of interest is over the area as a whole rather than mainly within each exchange area. For this reason it is undesirable to have the individual exchanges each with a self-contained numbering scheme using code dialling for calls between the exchanges. Instead, a single numbering scheme covering all subscribers in the complete multi-exchange system is introduced so that the objective subscriber's number only is dialled for a call anywhere within the area.

Non-director multi-exchange areas consist of a main exchange and one or more satellite exchanges.

The main exchange in addition to serving local subscribers in the central area, provides local and multi-fee tandem switching facilities and manual board services for the whole multi-exchange system. Satellite exchanges are thus generally dependent upon the main exchange switching equipment or manual board for completion of all calls except those between two subscribers both of which are served by the particular satellite exchange.

Some early small satellite exchanges had all calls, including local ones, connected via the main exchange but these were exceptional and few remain. They were known as full satellite exchanges.

The provision of satellite exchanges allows the subscribers' lines in the satellite area to be much shorter in length than if all subscribers were served from a large central exchange, but interconnecting junctions and extra exchange equipment are required.

The design of satellite exchange equipment gives scope for some ingenuity in order to economise both in exchange equipment and junctions. A considerable amount of development has taken place in the design of satellite exchange equipment since the first satellite exchange was opened but most schemes have retained the basic features of digit absorption on local calls to reduce the number of ranks of group selectors, and a discriminating arrangement to separate junction and local calls for routing purposes. These features are discussed in more detail later.

NEED FOR REVIEW OF EQUIPMENT ARRANGEMENTS IN MULTI-EXCHANGE AREAS

The British Post Office methods of design of multi-exchange areas on the basis of a central main exchange surrounded by a number of discriminating satellite exchanges were evolved many years ago, since when a number

of changes have been taking place, which could well affect the principles on which these methods were based. The most important of the changes concerned are:—

(i) The normal size for new and re-defined multi-exchange areas has been reduced. Formerly a multi-exchange area could include exchanges located up to five miles from the centre, but on re-definition of an area, an endeavour is made to include only those within about three miles of the centre.

(ii) The introduction of multi-metering up to four unit fees has added to the cost and complication of exchange equipment.

(iii) The increased local line plant planning limits introduced in 1946 have extended the use of small gauge local cables and altered the design of cable schemes. On a long term basis, it is probable that a further increase of planning limits will occur.

(iv) Since the development of the 2,000-type satellite discriminator, systems employing somewhat different techniques of discrimination have been employed abroad.

THE PRESENT STANDARD—2000-TYPE SATELLITE DISCRIMINATOR

A typical trunking diagram for three satellite exchanges and their main exchange is shown in Fig. 1. Satellite exchanges B and C are similar to A, but to avoid undue complication of the diagram, the separate C.C.B. first selectors and complete routes from junction levels have been omitted. The 2,000-type selector used in the normal manner cannot be operated as a discriminating selector repeater giving digit absorption because, owing to its rectangular release action the release time is, under many circumstances, too great for the inter-digit pause which may be encountered. The discriminatory and digit-absorbing facilities are therefore incorporated in a separate discriminator. At satellite exchanges special satellite first selectors are associated with the discriminators via hunters. A discriminator and a satellite first selector are brought into use on every call originated by a subscriber. Calls to local subscribers are connected via the appropriate levels of the satellite first selector, and calls to the manual board are connected via level "0" of that selector. Junction calls to other exchanges are switched over any selected spare level or levels of the first selector via junctions (M.E. group) to first selectors at the main exchange. The satellite first selector in this instance, acts simply as a junction hunter. For all calls the

†The authors are, respectively, Assistant Staff Engineer, Telephone Development and Maintenance Branch; and Senior Executive Engineer, Exchange Equipment and Accommodation Branch, E.-in-C.'s Office.

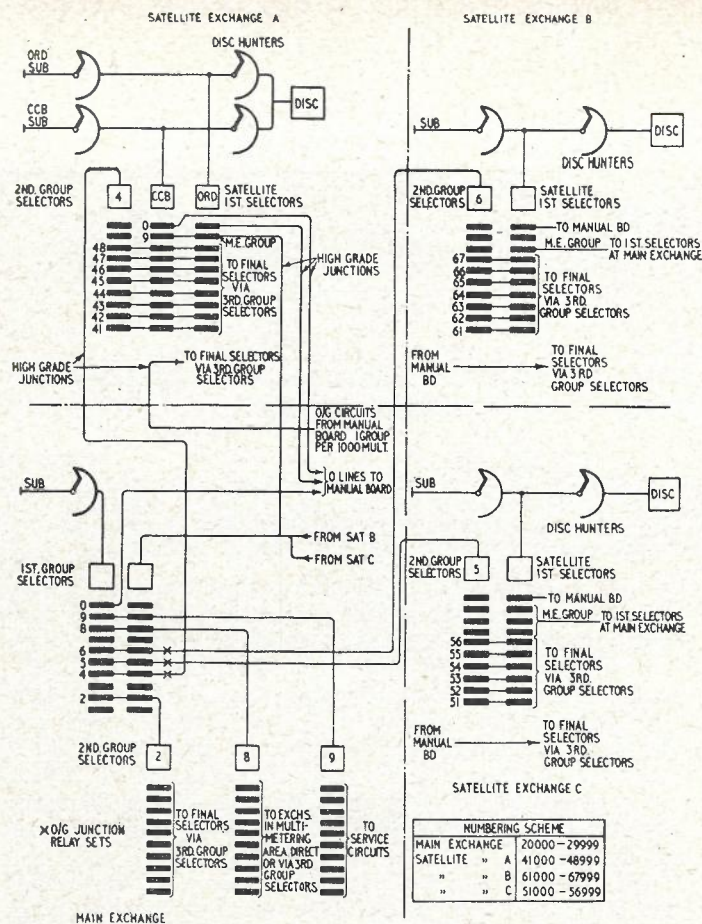

FIG. 1.—2,000-TYPE DISCRIMINATOR SATELLITE SCHEME.

discriminator is held until the called subscriber answers or until sufficient digits have been dialled to indicate that metering is not required.

Discrimination is effected for three main purposes, viz:—
Routing.

Discrimination is given on the first or first two digits to route the call in one of the following ways:—

- To local selectors, usually with absorption of the first digit, the satellite first selector then acting as a second group selector.
- To first selectors at the main exchange for calls to the main exchange (including "9" level calls when the code "94" is not used for "trunks"), to other satellites, and to exchanges outside the multi-exchange area but within the subscribers' permitted dialling range. In these cases the discriminator causes the satellite first selector to act as a junction hunter by stepping to a level on which the M.E. group of junctions appears and hunting for a free outlet. When the free junction has been seized, the discriminator repeats forward all the dialled information, including the first digit.
- Direct to the auto-manual board via separate groups of junctions for "0" level calls.
- To second selectors at the main exchange via a separate group of junctions for "9" level calls when code "94" is used for "trunks."

Metering, Barring and Manual Hold.

The discriminator applies the required conditions according to the digits dialled in respect of the following classes of traffic:—

- Calls to subscribers in the M.E. area.**—Single fee metering where the first digit indicates that a M.E. area subscriber is required. In the event of a spare

level being dialled, a forced release signal is sent to the satellite first selector which returns N.U. tone to the caller.

- Calls to service points ("0" and "9" level calls).**—Metering, or non-metering and/or manual hold conditions are applied according to the first, first two, or first three digits dialled. Manual hold conditions are set up by the satellite first selector on receipt of a signal from the discriminator.
- Calls to exchanges outside the M.E. area.**—One, two, three or four metering pulses are applied according to the first two or first three digits dialled, or forced release is signalled to the satellite first selector in the event of a spare or barred code being dialled. The discriminator provides metering discrimination for these purposes on 10 two-digit or 100 three-digit codes.

The extent to which exchanges within 15 miles chargeable distance of the satellite exchange can be made available is subject to the limitations of the multi-metering scheme employed at main exchanges, since all calls to exchanges outside the multi-exchange area are routed via the main exchange. Main exchanges at present use the "restricted" multi-metering scheme, whereby exchanges which are outside the multi-exchange area but within subscriber dialling range, and which can be reached by *direct junctions*, are usually grouped in such a way that each level of second selectors serves exchanges having a common fee. This enables the fixed fee multi-metering relay sets, controlling metering to main exchange subscribers, to be on second selector levels in all such cases.

C.C.B. Subscribers' Identification.

Discrimination between ordinary and coin box subscribers at the satellite exchange is effected by connecting them via separate groups of satellite first selectors and discriminator hunters to the discriminators. This permits signals to be passed to the discriminator enabling it to apply the necessary discriminatory conditions—mainly the barring to coin box subscribers of calls other than unit fee and certain special services. The equipment is capable of generating and passing forward signals over a common "0" level group of junctions to enable an operator to distinguish between an ordinary and a C.C.B. caller. This facility is not, however, used—it is the practice to provide separate groups of "0" level junctions for ordinary and C.C.B. subscribers.

In general, therefore, traffic originating at a satellite exchange which is destined for subscribers not connected to that exchange passes over one of three or four groups of junctions to the main exchange. This concentration of traffic leads to higher efficiency of junction usage, but has the disadvantage that the grade of junction must be suited to the most onerous routing which may be completed via that link.

Where a satellite exchange has the whole of a level allocated to it, only one group of incoming junctions from the main auto equipment is required. Additionally, of course, there is need for junctions incoming from the manual board. It is the standard practice to provide junctions incoming from the manual board to the penultimate switching rank, to reduce operating functions. Hence, one group of junctions per thousand multiple is provided. If a satellite exchange shares a level with one or more other satellite exchanges, it is necessary to provide second selectors at the main exchange and a group of junctions per 1,000 multiple incoming from the main auto equipment also.* For incoming junctions, as with outgoing

*The arrangement adopted in this case is similar to that illustrated in Fig. 4.

junctions, the grade of circuit provided must be suitable for the most onerous routing which may be completed over them. This may lead, under operator trunk dialling conditions, to all incoming circuits being of high grade.

POSSIBLE ALTERNATIVES TO THE STANDARD SCHEME

Several schemes whereby the 2,000-type selector may be used as a D.S.R. have been developed in recent years.* The main ones are:—

(i) *Fast release.*—Discrimination is effected on a vertical marking bank, and release is accelerated by using a rotary magnet of reduced resistance in series with a non-inductive resistor. Hunting into the bank is at normal speed.

The trunking arrangements of this scheme are similar to those of the pre-2,000-type D.S.R. scheme, but the availability per level is 20 instead of 10.

(ii) *Level "1" discrimination.*—On seizure the selector steps up to, but not into, level "1". The first digit steps the selector into level "1" and discrimination takes place, followed by rectangular release. Since the selector is not, at this stage, above level "1" and is some way into the level, the release time is less than when discrimination is effected on the vertical marking bank.

The trunking arrangement is similar to that of the pre-2,000-type D.S.R. scheme. The availability for level "1" is reduced from 20 to 10 as the P2 wiper and bank are used for discrimination. For levels 2-0 inclusive the availability per level can be 20.

(iii) Combinations of (i) and (ii) giving one and two digit discrimination.

Other possible schemes are:—

(iv) *Motor unselector used as a D.S.R.*—Discrimination is effected by counting the first digit on an ordinary unselector. The motor unselector is brought into use after discrimination and can act either as a junction hunter or as a second selector.

The designs of schemes (i)-(iv) do not, in themselves, provide for multi-metering, but they could all be arranged to do so in the same way as has been done for the pre-2000-type D.S.R. scheme, i.e., by associating a hunter giving access to multi-metering discriminators with each D.S.R. The general trunking of such schemes however would be practically the same as for the 2000-type satellite discriminator scheme. The holding times and therefore the quantities of selectors, hunters, and discriminators required would be similar. The costs are therefore unlikely to be significantly different from those for the 2000-type equipment.

(v) *2000-Type Group Selector Satellites.*—No discriminating or digit absorbing facilities are provided for routing calls within the linked numbering scheme. Each satellite exchange in a M.E. area is connected to each other satellite exchange by a single group of direct junctions, except in those cases where exchanges share first selector levels and economic considerations may warrant either direct groups of junctions for each 1,000 multiple or routing via tandem at the main exchange. "0" and "9" level services are routed via separate groups of junctions to the main exchange. Calls to exchanges outside the multi-exchange area, but within the permitted dialling range of 15 miles, are routed via another group of junctions to second selectors at the main exchange. For multi-metering purposes a variable fee multi-metering relay set is required on these junctions.

Since digit absorption and discrimination for routing purposes is not employed, the special satellite first selector

*The pre-2,000-type discriminating selector repeater uses an obsolescent type of switch, and, although equipment has now been designed to provide multi-metering at existing exchanges, this system is not considered in detail in this article.

equipment which is used in most of the discriminatory schemes, is replaced by standard group selectors. For this reason this scheme is referred to as the Group Selector Satellite Scheme. This scheme appeared to have some possible advantages, and its cost has been compared with the present standard. It is, therefore, described in some detail in the following paragraphs.

TRUNKING ARRANGEMENTS OF A MULTI-EXCHANGE AREA WITH GROUP SELECTOR SATELLITE EQUIPMENT

A system with four exchanges (similar to that of Fig. 1) is used to show the general principles and Fig. 2 illustrates

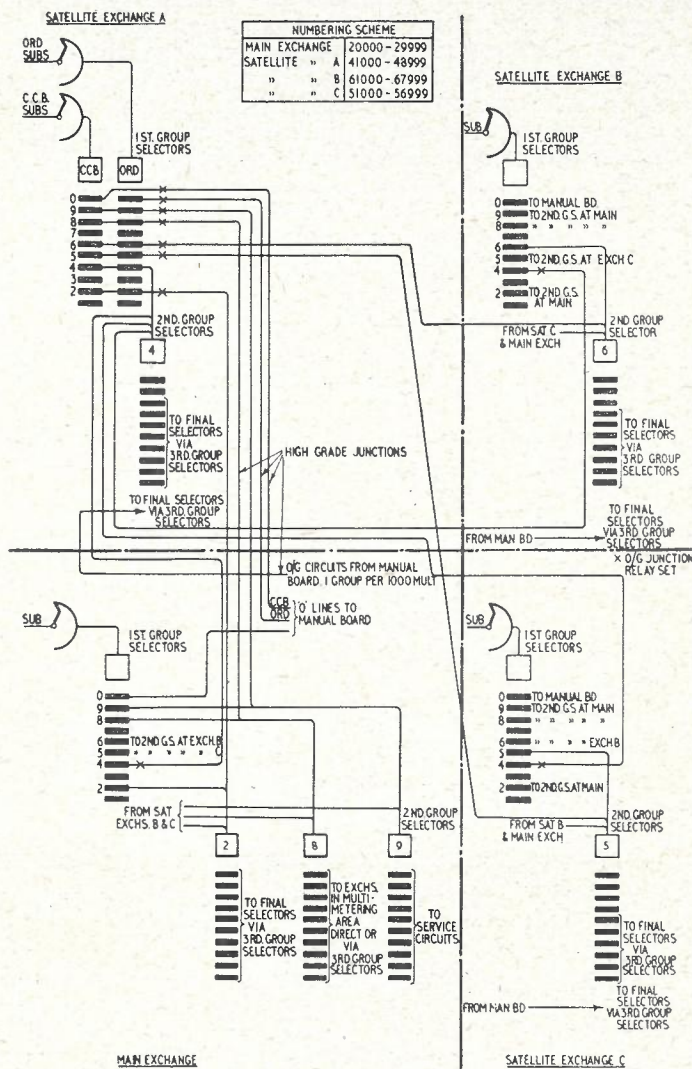

FIG. 2.—GROUP SELECTOR SATELLITE SCHEME.

the trunking arrangements in outline form. The full details of a complete exchange installation have of necessity been omitted to avoid undue complication of the diagram, but satellite exchange A has been shown in sufficient detail to illustrate the effect on the junction network and switching equipment when group selector working is introduced. Satellite exchanges B and C are similar to A but the separate C.C.B. first selectors and complete routes from junction levels are omitted from the diagram. It is assumed that satellite A has 8,000 multiple, satellite B 7,000 multiple and satellite C 6,000 multiple.

At the satellite exchanges the number of outgoing junction groups is seven, of which five are to the main exchange and two to the other satellite exchanges. There are also three incoming groups of junctions, one from the main exchange,

and one each from the two satellite exchanges. In addition there is one group per 1,000 multiple from the manual board. This may be compared with Fig. 1 which shows four outgoing groups and one incoming group. The manual board junction groups are the same in Figs. 1 and 2. A system with more satellite exchanges would require additional junction groups for Fig. 2 but Fig. 1 would remain unchanged as traffic to any number of satellite exchanges would be routed over the one M.E. group of junctions to the main exchange.

Fig. 2 does not illustrate the requirements of a large multi-exchange system. When the number of exchanges exceeds the number of first selector levels available for subscribers numbers (at present usually six levels) it becomes necessary for some satellite exchanges to share a level, i.e., the subscribers numbers on the exchanges concerned commence with the same initial digit. When this occurs two alternative methods of routing are practicable. Each satellite exchange may be provided with second selectors on the level concerned, with groups of direct junctions to the two satellite exchanges sharing the level or alternatively the first selector level may be trunked to second selectors at the main exchange and from there to the two satellite exchanges.

Fig. 3 shows the first alternative in outline. Satellites A

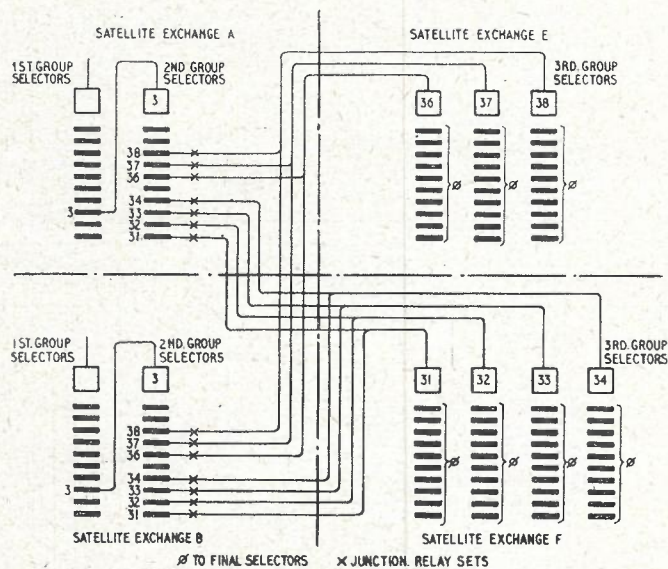

FIG. 3.—TRUNKING FOR SATELLITE EXCHANGES WITH THE SAME INITIAL DIGIT; DIRECT JUNCTION SCHEME.

and B are typical exchanges from which a call is assumed to originate, Satellites E and F are the two exchanges which have the same initial digit, in this case three. Only the switches and junction groups concerned are shown.

It will be seen that each originating exchange (A and B are typical) has several groups of junctions (1 per 1,000 multiple) to the sharing satellites E and F. Compared with Fig. 2 in which no exchanges share initial digits a considerable increase in the number of junction groups results. This is minimised by adopting the second alternative, shown in Fig. 4, where only one junction group is provided on level 3 which is routed to second selectors at the main exchange and only from here are the separate groups of junctions to the satellite exchanges E and F provided. These groups will thus be used jointly by all exchanges and an overall saving in total junction route mileage may be obtained. The arrangement becomes similar to discriminator working in respect of the number of junction groups.

For exchanges sharing a particular level, e.g., exchanges E and F, routing on that level (3) via the main exchange would not be adopted as it would involve local calls being

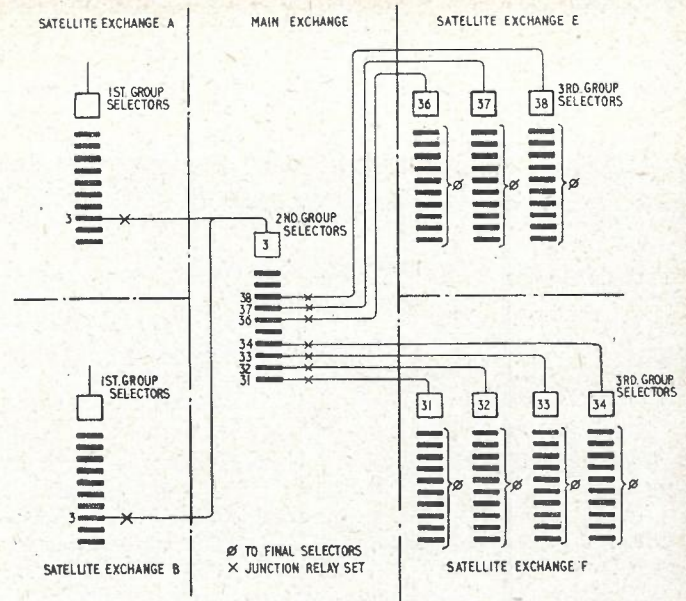

FIG. 4.—TRUNKING FOR SATELLITE EXCHANGES WITH THE SAME INITIAL DIGIT; SCHEME WITH ROUTING VIA MAIN EXCHANGE.

connected out to the main exchange and then back to the originating satellite exchange. Second selectors would be provided at exchanges E and F on level 3 and the local levels (36-38 at exchange E) connected to third and final group selectors, the other appropriate levels (31-34 at exchange E) being connected over the separate junction groups to the other sharing exchange.

The general effect of group selector working is therefore to increase the number of junctions, although many of the direct junctions may be much shorter than junction routing via the main exchange. Moreover, as usually only one type of traffic circulates over a particular junction group, the potential savings by using low-grade junctions (from a transmission standpoint) for certain types of calls, may more generally be realised.

The type of equipment required at group selector satellite exchanges is rather more simple than at discriminator exchanges. It embraces the step-by-step principle in its simplest form with a switching train consisting of subscribers' uniselectors followed by group selectors and terminating in final selectors.

The full number of ranks of switches is required as no digit absorption occurs. Additional equipment is necessary for junction calls and an appropriate type of relay set is included in trunks from those selector levels connected to junctions. On junctions direct to other satellite exchanges and to main exchange subscribers, standard auto-to-auto relay sets are fitted. On the junctions to the main exchange for multi-metered calls, i.e. to exchanges within 15 miles radial distance (usually obtained from level 8 as shown in Fig. 2) a new relay set has been designed for the satellite exchanges. Apart from the usual transmission bridge and holding features the relay set includes facilities for counting the second and third digits dialled and applies the appropriate number of meter pulses when a call is established. In addition, where calls beyond 15 miles might be obtained via the main exchange, these can be barred by the relay set. This barring facility is required for those satellite exchanges which have call charges based on radial distance from the satellite exchange instead of the main exchange. The multi-metering network from the main exchange would give access to all exchanges within 15 miles of the main exchange and connected by direct junctions, and might include some exchanges over 15 miles from a particular satellite exchange. The relay set also allows call office

circuits access to level 8 for calls to exchanges outside the linked numbering scheme but within unit fee distance. Direct access for other calls on level 8 are barred to call office users.

The relay set used on the service level (level 9) at the satellite exchange gives either single fee metering or manual hold conditions dependent upon the service required and governed by the signalling conditions sent back from the individual service level relay set at the main exchange. The level "0" relay set gives standard manual board facilities. Both "9" and "0" level relay sets are in current use and no new design is involved.

The introduction of group selector working at satellite exchanges thus allows the simplest and least expensive equipment to be used.

The question which arises however is whether the savings with the simple type of satellite exchange equipment will offset the extra line costs of the additional junctions and the Bournemouth multi-exchange system has been examined in detail to resolve this question.

COMPARISON OF COSTS OF THE TWO SYSTEMS

Bournemouth was used for the study as up-to-date traffic data for the whole area was available in connection with conversion from manual to automatic working, and it was reasonably representative of a medium-sized non-director multi-exchange system.

Details of the size and traffic distribution for the Bournemouth area estimated as at 1968 are given in Table 1 and the relative disposition of exchanges and the junction mileages in Fig. 5.

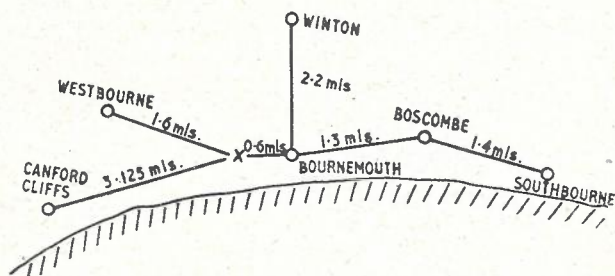

FIG. 5.—LAYOUT OF BOURNEMOUTH EXCHANGES.

The area as designed is quite straightforward. A five-digit numbering scheme is adopted, each satellite exchange has an individual initial digit and the number of junction routes is not inflated by any special numbering considerations under either system of working.

TABLE 1
Traffic details of Bournemouth Multi-Exchange Area

Exchange	No. of lines	Multiple required	Numbering range	Total originating traffic. T.U.s	Local traffic as per centage of total	Traffic to rest of M.E. area. Percentage of total
Bournemouth	7,407	8,400	21,000-29,999	262	46	25
Winton ..	6,666	7,200	51,000-58,199	119	23	48
Southbourne ..	6,384	7,000	41,000-47,999	102	29	40
Boscombe ..	5,116	5,600	31,000-36,599	120	26	46
Westbourne ..	3,296	3,800	61,000-64,799	85	17	40
Canford Cliffs..	1,661	2,000	71,000-72,999	39	28	46

Some indication of the amount of switching equipment required at each exchange is given by the number of racks of equipment scheduled in Table 2. These quantities are in respect only of group selectors (all types), discriminators and junction relay sets. Subscribers' uniselectors, meters and other equipment common to both schemes have been excluded.

TABLE 2
Switching Equipment Quantities

Exchange	Discriminator scheme	Group selector scheme
Bournemouth	69 racks	65 racks
Winton	23 racks	27 racks
Southbourne	23 racks	25 racks
Boscombe	26 racks	23 racks
Westbourne	19 racks	18 racks
Canford Cliffs	13 racks	12 racks
Total	183 racks	170 racks

The reason for the difference in group selectors required at Bournemouth exchange is that with the discriminator scheme, the M.E. groups of junctions from satellite exchanges require first selectors at the main exchange. Moreover, as all traffic circulates via the main exchange there are more o/g junction relay sets. At the satellite exchanges, with discriminator working fewer switches are required, but the special first selectors and the discriminators are large items and only a small number is accommodated on a rack. The nett result is that the overall number of equipment racks is slightly greater than for group selector working.

Details of the route mileage of the junction network are given in Table 3. Although there is an increase in junction mileage with group selector working the cost is not proportionately higher as only 54 per cent. of the junctions need high-grade transmission characteristics, whereas with discriminator working 76 per cent. must be suitable for high-grade transmission.

TABLE 3
Route Mileage of Junction Circuits

Exchange	Discriminator scheme	Group selector scheme		
		Route mileage		
		To Bournemouth	To other Satellites	Total
Winton	684	612	194	806
Southbourne.. ..	675	596	177	773
Boscombe	366	295	183	478
Westbourne	475	447	166	612
Canford Cliffs ..	436	428	103	531
Total	2,630			3,200

The difference in route mileage of junctions for the two schemes is not great. This is because with both systems there are substantial groups of circuits to the main exchange for traffic to Bournemouth exchange, to exchanges outside the linked numbering scheme but within 15 miles (with automatic access and multi-fee registration) and to exchanges over 15 miles distant (including trunk traffic). Inter-satellite exchange traffic, for which a larger junction network becomes necessary under group selector working, is relatively small and the number of additional junctions is not therefore great compared with the total. Moreover, between Boscombe and Southbourne, and to a lesser extent between Canford Cliffs and Westbourne, the direct junction route mileage is less than that of the indirect routing via the main exchange.

The comparative costs of the two systems have been estimated and produced on a basis of the annual charges for each scheme, thus taking into consideration the higher maintenance costs for any complicated equipment. A comparison of capital costs only would not, of course, be satisfactory.

It is usual when considering schemes over a period to capitalise the annual charges as a "Present Value of Annual Charges" (P.V. of A.C.). This is to obtain a measure of the effect of charges occurring, ceasing or changing at different times over the period.

In this study the subscribers' development and therefore increase in plant capacity is identical at corresponding dates for each scheme and a comparison at a particular fixed date allows the annual charge basis to be used.

The total cost of the two schemes is given in Table 4 and it will be seen that the group selector scheme shows a saving of £4,300, some 5 per cent. of the total annual charges.

TABLE 4
Costs of the two schemes

	Annual charges (£)	
	Discriminator scheme	Group selector scheme
Bournemouth equipment ..	34,000	32,700
Winton equipment	13,100	11,900
Southbourne equipment ..	12,000	11,400
Boscombe equipment	10,800	9,900
Westbourne equipment ..	7,500	6,800
Canford Cliffs equipment ..	4,200	4,000
Total for exchange equipment	81,600	76,700
Total for junctions	2,800	3,400
Total for junctions and equipment	84,400	80,100

The study indicates that for the Bournemouth area discriminator equipment is not as economical as group selector equipment. It is interesting to note that a small satellite exchange some distance from the main exchange may be almost as expensive when equipped with group selectors as with discriminators and the junction costs could throw the balance in favour of discriminator working. This tendency is illustrated at Bournemouth by the Canford Cliffs exchange. It would have to be smaller and more distant from the central area than it is before the group selector scheme proved more expensive. It is not considered that in practice in this country any satellite exchanges will be found more economical as discriminator exchanges.

It should be mentioned that the Bournemouth area has features which tend to favour group selector working. The exchanges are all of fair size and only six in number. The junction groups are of fair efficiency and not unduly numerous and the distances are reasonably short. In addition the geography of the area, along the sea coast, allows short direct junctions between Boscombe and Southbourne. All these factors tend to keep the junction costs of group selector working low. Further study of a hypothetical area was, therefore, made to obtain information of the effect of size, calling rate, number of exchanges and distance between exchanges in order to decide whether general application could be considered.

The area was laid out in a manner likely to prejudice the adoption of group selector working, particularly in so far as the junction costs were involved.

Book Review

"Electrical Units, With Special Reference to The M.K.S. System." Eric Bradshaw, M.B.E., M.Sc.Tech., Ph.D., M.I.E.E. Chapman & Hall. 64 pp. 9 ill. 9s. 6d.

Professor Bradshaw contributed one of the four papers to the Symposium on the M.K.S. system of units organised by the I.E.E. in 1950. He is an advocate of the M.K.S. system in its rationalised form and is specially concerned with its use in education. The whole subject is treated very thoroughly from many aspects, but the subject is not very big and neither is the book. The many tables of formulæ and conversion factors, apart

From this further study it has been established that it is generally more economical to adopt group selector working rather than discriminator working as a standard for satellite exchanges in this country. It will no doubt be appreciated, however, that this conclusion would not necessarily apply where the basic factors such as size of M.E. areas, telephone density, calling rate, ratio of external and internal plant costs, etc., varied substantially from the general conditions in the United Kingdom.

CONCLUSIONS

The costs of the 2000-type group selector satellite scheme show overall savings of some 5 per cent. in respect of annual charges on switching equipment and junction line plant as compared with the 2000-type satellite discriminator scheme. Detailed cost figures indicated that, for the satellite discriminator scheme, the annual charges on the satellite first selector and discriminator equipment were about 10 per cent. of the total annual charges. Thus, the 5 per cent. savings are equal to about half of the annual charges on this equipment. For any other discriminator scheme to prove more economical than group selector satellite working, therefore, it would be necessary for the annual charges on its first selector and discriminator equipment to be less than half of those on the similar standard equipment. Since this is considered to be impracticable, detailed costing of alternative discriminator schemes is not warranted.

Whilst the cost studies indicate that the 2000-type group selector satellite system is cheaper overall than the discriminator schemes, the saving is not large, and in the absence of other considerations might be judged insufficient to warrant a change from existing standards. The group selector system has, however, some important general advantages, as follows:—

- The main exchanges and satellites use the same type of equipment. That is, standard group selectors, final selectors and relay sets are used throughout a multi-exchange area, with obvious advantages in respect of training and interchange of staff, numbers of types of equipment, and stocks of items held for maintenance replacements. The only differences between a satellite and main exchange are the variable fee multi-metering relay set and the "9" level relay set.
- The equipment is in general simpler, which should lead to ease of maintenance and improved service, and, as in (a) above lead to smaller training costs and greater flexibility in the employment of staff.
- The satellite exchanges are more independent and therefore not so likely to be affected by any interruption of service at the main exchange.

It is, therefore, concluded that for non-director multi-exchange areas in this country 2000-type group selector satellite exchanges will prove to have such advantages over the discriminating type as to justify adoption.

from the elucidatory material, will make it a very useful reference book. Some care has evidently been taken with notation, which is of great importance in the treatment of such a subject, and the result is, on the whole, excellent, but the removal of one or two minor inconsistencies would improve matters: thus it would be preferable to avoid using t both for time and thickness, to use a exclusively for area (not sometimes A), to use V exclusively for potential difference (not sometimes E) and to retain consistently the brackets in (T) for turns. On page 50 the resistance of free space should, of course, be $\sqrt{(\mu_0/\epsilon_0)}$ not $\sqrt{(\mu_0\epsilon_0)}$.

W. E. T.

U.D.C. 621.395.636: 621.316.93

This article describes equipment which provides a relatively simple and economical means of signalling over U.A.X. junctions which have no D.C. signalling path. The immediate need for the system arises from the protective measures necessary in "parallelism" cases in Scotland, where isolating transformers are inserted in overhead junction lines to limit the induced voltage, should the parallel high voltage power lines develop a fault.

INTRODUCTION

THE recent extensive development of electric power in the Scottish Highlands by the North of Scotland Hydro Electric Board has involved the construction of many new power lines, and due to the nature of the terrain these have often to run close and parallel to Post Office overhead lines. Power line faults may, under such conditions, cause very high voltages to be induced in the adjacent telephone lines, and protection must therefore be provided for the safety of subscribers, Post Office staff and equipment. Wherever possible this is done by earthing the telephone lines through gas discharge tube protectors¹ whenever a high voltage is present. Under adverse conditions of induced voltage or earth resistivity, however, the use of gas discharge tubes is not satisfactory and it becomes necessary to divide the telephone line into a number of sections by inserting isolating transformers. Signalling System A.C. No. 5X has been developed to meet the need for a signalling system with which signal impulses may be transmitted over such U.A.X. junctions having no D.C. signalling path.

It is sometimes found that subscribers' lines also need the protection given by isolating transformers and, to overcome the signalling problem, equipment was developed to enable the subscribers concerned to use magneto signalling to the U.A.X. So far, however, it has proved more convenient to provide a new U.A.X. near the subscribers concerned, so reducing "parallelism" and enabling the subscribers' lines to be worked normally. The junctions to such U.A.X.s, however, need isolating transformers and consequently have to be equipped with signalling system A.C. No. 5X.

SIGNALLING CONDITIONS

50 c/s A.C. taken from the supply mains and stepped down to a suitable voltage, is the cheapest and simplest source of A.C. to use for signalling over the isolating transformers; and only by using a very low signalling frequency may a sufficient level of signal be transmitted to operate a receive relay directly, thus avoiding a valve-type V.F. receiver with its continuous power drain, which would be undesirable at a U.A.X. Also, by using a high signal level voice immunity problems can be avoided, since the receive relay will be insufficiently sensitive to operate on speech. It might be thought that the use of 50 c/s for signalling would be liable to interference from the 50 c/s power line voltages. However, such induction is always longitudinal and the loop voltage induced represents the difference between the voltages induced in the two lines and is not likely to affect the system. Nevertheless, there seems a possibility of transient surges of exceptionable magnitude being induced (e.g. during operation of power switchgear, or due to power line faults) and to avoid false seizures a double, instead of a single, pulse seizure signal has been used.

PULSE CODES

The pulse codes were designed to meet the following requirements:—

- (a) Different signals to be provided for various functions, e.g. answer 2 pulses, backward clear 1 pulse, for an incoming call. Since the circuits were to be bothway,

the same signals and circuit elements could function in each direction, e.g. call 2 pulses, clear 1 pulse, for an outgoing call.

- (b) The release, or clearing signal to override all others, e.g. a long pulse compared with the short pulses for other signals.
- (c) Signals of critical timings to be avoided.

The signalling codes and impulses transmitted over a junction are as follows:—

Call and Answer	<u>63</u>	34	<u>63</u>	pulses of 50 c/s A.C.
Clear		<u>63</u>		pulse of 50 c/s A.C.
Impulses	<u>54</u>	46	<u>54</u>	pulses of 50 c/s A.C. corresponding to the break impulses from the dial.

The figures on and between the pulses represent the nominal timing in milliseconds; the departure from the standard 10 i.p.s. with break/make ratio of 2 : 1 is explained later. In addition to the short pulse signals, the release and the distant test busying of junction equipment have been catered for by increasing the pulse period. To effect the release of the distant equipment a pulse of 800 mS is generated and transmitted, but for test busying a junction and its distant termination a continuous 50 c/s signal is transmitted. Conversely, when a free termination receives a single short, long or continuous 50 c/s signal, including a surge that may be induced from a neighbouring power line, the termination is busied for the duration of the signal and released to the free condition as the signal ceases; this ensures that a surge, or fault on the power line, does not lock-up all the junctions on a route.

TYPICAL SIGNALLING CHARTS

Tables 1-4 show the number, direction and duration of the pulses and their signalling functions for various types of connection. The pulse timings given in milliseconds are nominal.

TABLE 1
Outgoing Call from U.A.X. to Manual Exchange

U.A.X. No. 12 Operations	Pulses over Junction	Manual Exchange Operations
Seizure of circuit from selector level outlet. Caller receives ring tone.	63 → 34 → 63	Calling signal operates.
Ring tone disconnected.	← 63 ← 34 ← 63	Operator answers.
Caller clears. Manual hold condition.	→ 63 →	Supy. clear signal to operator.
Caller recalls.	→ 63 → 34 → 63	Supy. answer signal to operator.
Circuit and preceding equipment released.	← 800 ←	Operator clears connection. Terminating equipment transmits release pulse and releases.

† Assistant Engineer, Telephone Development and Maintenance Branch, E.-in-C.'s Office.

¹ P.O.E.E.J., Vol. 45, pp. 104 and 108.

TABLE 2
Incoming Call from Manual Exchange

U.A.X. No. 12 Operations	Pulses over Junction	Manual Exchange Operations
Circuit and selector seized. Dial tone returned.	63 ← 34 ← 63	Operator plugs into junction. Termination seized.
Pulses partially corrected and repeated as loop-disconnect impulses to selector.	51 51 51 ← 49 ← 49 ←	Operator dials. Pulses corresponding to the "breaks" from the dial transmitted.
Called party answers.	63 → 34 → 63	Supy. answer signal to operator.
Called party clears.	63 →	Supy. clear signal to operator.
		Operator clears connection. Terminating equipment transmits release pulse and releases.
Circuit and subsequent equipment released.	800 ←	
Test Busy Conditions		
Continuous 50 c/s A.C. extended by U.A.X. to busy the termination at the manual Exchange.		

TABLE 3
Outgoing, Auto-Auto Call

U.A.X. No. 12 Operations	Pulses over Junction	Tandem U.A.X. Operations
Seizure of circuit from selector level outlet during intertrain pause.	63 → 34 → 63	Seizure of I/C equipment.
Loop-disconnect impulsing received by regenerator, delayed and sent to line as pulse signals corresponding to the breaks of the dial.	54 54 54 → 46 → 46 →	Pulses converted to loop-disconnect impulses by the regenerator, corrected and then re-transmitted to selectors.
Metering conditions applied to D-wire.	63 ← 34 ← 63	Called subscriber answers.
C.S.H. conditions. Time pulse release causes (i) forced release of circuit and preceding equipment and (ii) the generation and transmission of a release pulse.	63 ←	Called subscriber clears first.
Calling subscriber clears first (or within the time pulse period). Circuit and preceding equipment released.	800 →	U.A.X. equipment released.
	800 →	U.A.X. equipment released.
Test Busy Conditions		
U.A.X. No. 12 Operations	Signal over Junction	Tandem U.A.X. Operations
Circuit busied manually, or regenerator fails to restore to normal. (Selector level outlet busied in both cases and a prompt alarm in the case of the regenerator failure.)	continuous →	Bothway junction equipment busied until the signal ceases.

TABLE 4
"0" Call from Dependent U.A.X. to Parent Manual Board via a Tandem U.A.X.

U.A.X. No. 12 (Dependent) Operations	Pulses over Junction	Tandem U.A.X. Operations
Seizure of circuit from selector level outlet.	63 → 34 → 63	Seizure of I/C equipment.
The "0" sender generates 1, 2 or 3 digits code, which is transmitted to route the call to the manual board.	63 63 63 → 34 → 34 →	Pulses received from line by the regenerator, corrected and transmitted to the selector as loop-disconnect impulses.
Manual hold and time pulse release conditions prepared.	63 ← 34 ← 63	(Operator answers.) U.A.X. disconnects ring tone and repeats the answer signal.
Caller clears; manual hold and circuits held.	63 →	Clear supy. signal extended to manual board.
Caller recalls from manual hold.	63 → 34 → 63	Recall signal extended to manual board.
		(Operator clears from manual hold condition.) Release pulse generated, connection and equipment released.
Circuit and preceding equipment released.	800 ←	(Operator clears whilst the calling party is on the line.) Clear pulse transmitted.
Calling party clears last, or C.S.H. time pulse release causes: (i) generation and transmission of release pulse, and (ii) forced release of circuit and preceding equipment.	63 ←	
	800 →	Release of equipment and connection to manual board.

FACILITIES GIVEN BY JUNCTION EQUIPMENT

The relay sets designed for this system replace the existing standard relay sets and to avoid fitting conversion equipment in the incoming as well as in the outgoing relay sets, the pulse signalling equipment was made for bothway working, although this involved having an additional transmission bridge in the incoming speech circuit. Conversion equipment has been designed for two types of junction, i.e. auto-manual and auto-auto.

Relay Sets on Auto-Manual Route.

Fig. 1 is a block schematic diagram showing the essential parts of the relay sets, their functions and interconnection. The relay sets incorporate a normal speech path with a transformer-type transmission bridge (TR1) to prevent spill-over of 50 c/s A.C. from one circuit to another; a forward signalling path which converts the D.C. signals to pulses and transmits these as 50 c/s A.C. to the junction; and a backward signalling path which accepts A.C. pulses from the junction via a 50 c/s tuned circuit and a bridge rectifier network, the resultant D.C. pulses operating a high-speed relay LS.

In both relay sets the counting chain relays PA and PB are common to both forward and backward signalling. In the auto relay set the contacts of the pulse generator relay

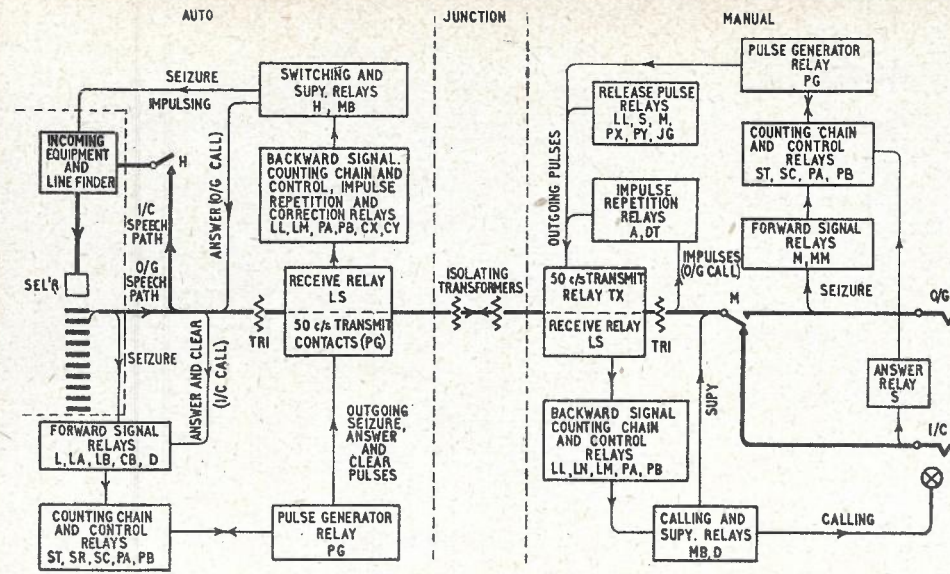

FIG. 1.—BLOCK SCHEMATIC DIAGRAM OF AUTO-MANUAL RELAY SETS.

PG (during forward signalling) disconnect the transmission bridge TRI and the 50 c/s receiving element from the junction, and connect to it the 50 c/s A.C. transmitting element. The release pulse is generated at the manual exchange only, to provide an operator-control feature for both outgoing and incoming calls and manual hold on calls from the auto exchange. The duration of the long pulse is produced by the release lags of relays PX, PY and JG, and the control, or start, of the pulse by relay LL, or S, or M depending respectively on whether the release is from an

unanswered call, or the operator clearing from an incoming call, or the operator clearing from an outgoing call. Trunk offering, C.C.B. discrimination and busy flash are not provided. The omission of these facilities was decided upon in order to reduce equipment complexity, since the equipment is likely to be used in very remote locations.

Relay Sets on Auto-Auto Route.

Fig. 2 is a block schematic diagram of the bothway relay set for a U.A.X. No. 12, showing the essential parts of the relay set, their functions and interconnections. The relay set at a U.A.X. No. 13 is similar, but it has no "0" sender. Either type can work back-to-back with a relay set of its own type and this allows the outgoing and incoming signal paths to be traced out on one diagram. The relay

set incorporates speech and signalling paths similar to those described for the auto-manual route relay sets, but has a number of additional features as described below.

A mechanical impulse regenerator² is provided, primarily to provide seizure time on outgoing calls to allow the two-pulse seizure signal to be sent; on incoming calls the same regenerator corrects for impulse distortion, which the use of a low frequency like 50 c/s inevitably produces.

An "0" sender uniselect is also necessary, and in conjunction with the pulse generating relay PG, produces and transmits the pre-determined routing digits required to direct the call to a distant operator when a calling subscriber dials "0." Where the assistance operator is situated in an auto-manual exchange, the sender can be arranged to send out two different codes, one to route ordinary subscribers' calls, and the other to route C.C.B. subscribers' calls to the manual board via different selector levels, in order to provide C.C.B. discrimination to the operator.

A release pulse element formed by slow release relays IP, IS and KA operates on clear-down by the caller at the end of an outgoing auto call, or by the time pulse release feature on a P.G. or C.S.H. condition. The release pulse, however, is suppressed on a manual board call during the period the operator has a plug in the answering jack; thus manual hold is provided.

In the auto-auto relay set certain items are common to both the incoming and outgoing signalling and impulsing paths, i.e. the counting chain relays PA and PB, the impulse regenerator with its associated BY and DK relays, and the intertrain pause relays IP and IS.

The contacts of relay PH are used to disconnect the transmission bridge and the receiving element from, and connect 50 c/s A.C. to, the junction for both signalling and impulsing out.

Although the forward and backward signalling paths have been shown separated, both are used on either every answered outgoing, or incoming call; e.g., relay MB in the backward signal path is the answer relay on outgoing calls and its release by relay DR (operating to a clear signal) brings in C.S.H. conditions. At a tandem U.A.X. No. 13 relay DR also releases the switching relay H on an incoming call, in order to repeat the clear signal to the subsequent equipment. Similarly, relay D is associated with the forward signalling path to produce the answer and clear pulses on an incoming call.

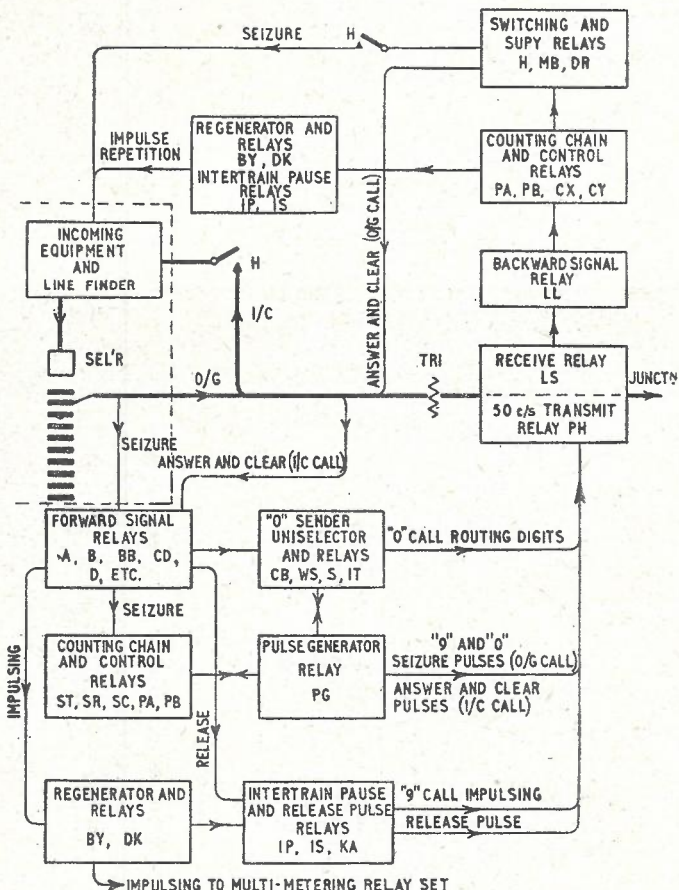

FIG. 2.—BLOCK SCHEMATIC DIAGRAM OF AUTO-AUTO RELAY SET.

² P.O.E.E.J., Vol. 30, p. 261.

The circuit operations in conjunction with the associated multi-metering equipment remain the same as for a D.C. junction. Trunk offering by operators and busy flash have not been provided.

PULSE RECEIVING, SIGNALLING AND CORRECTION ELEMENTS

The following descriptions are restricted to the new pulse conversion elements and do not cover the usual functions of the impulsing (A) relay, guarding (B) relay, intertrain pause (IP & IS) relays, answer (D) relay, etc., which form part of the relay sets. The principle in the block schematic diagrams (Figs. 1 and 2) is perpetuated by showing separately in the circuit diagrams the elements in their forward and backward signalling functions, which involves showing the same relay in more than one diagram.

Pulse Receiving and Transmission Bridge.

The pulse receiving and transmission bridge elements are shown in Fig. 3. The incoming pulses of 50 c/s A.C. (back-

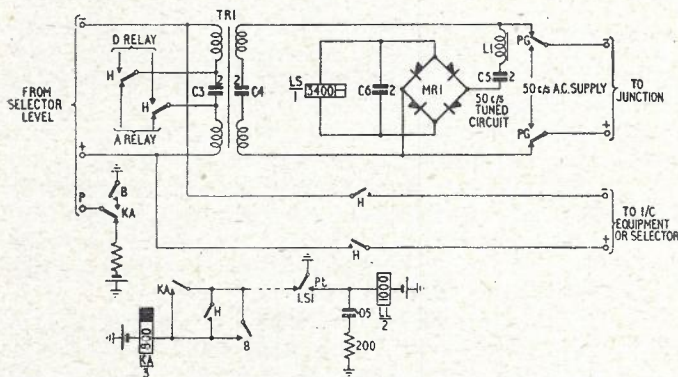

FIG. 3.—PULSE RECEIVING AND TRANSMISSION BRIDGE CIRCUIT ELEMENTS.

ward signalling) from the junction circulate via the tuned acceptor circuit L1, C5 and the bridge rectifier network MRI. The D.C. output is then smoothed by C6 to operate the high-speed relay LS. The high impedance of the bridge transformer TR1 to low frequencies prevents spill-over of 50 c/s A.C. to succeeding circuits. Following the reception of two seizure pulses, the H contacts switch the speech path and the supervisory relay D to the incoming equipment. Relay KA is the main hold and guard relay for both outgoing and incoming calls, and in the auto-manual circuits acts as the release relay when released by a pulse of 800 mS or more. On release by the calling party on an outgoing auto-auto call, relay KA is released by another element not shown. Relay LL is the line relief relay which repeats the signalling and impulsing pulses to subsequent elements. Contacts of the pulse generator relay PG have been included to show the disconnection of the receiving element and the application of 50 c/s A.C. to the junction during forward signalling.

Forward Pulse Signalling.

The generation of short pulse signals, e.g. seizure, answer, backward clear and forward clear under manual hold conditions only, is shown in Figs. 4 and 5. In Fig. 5 a full line represents a relay operated, and a dotted line with arrows the relay sequence, i.e. the relay contact which causes the operation or release of another relay or relays. It can be seen that for each seizure and release of the circuit by relay B, or relay D, two and one pulse signals are generated respectively, this sequence being controlled by relay SC. The onset of a signalling condition, e.g. the operation of relay D when the called subscriber answers, results in the generation of two pulses and the lock-up of relay SC to

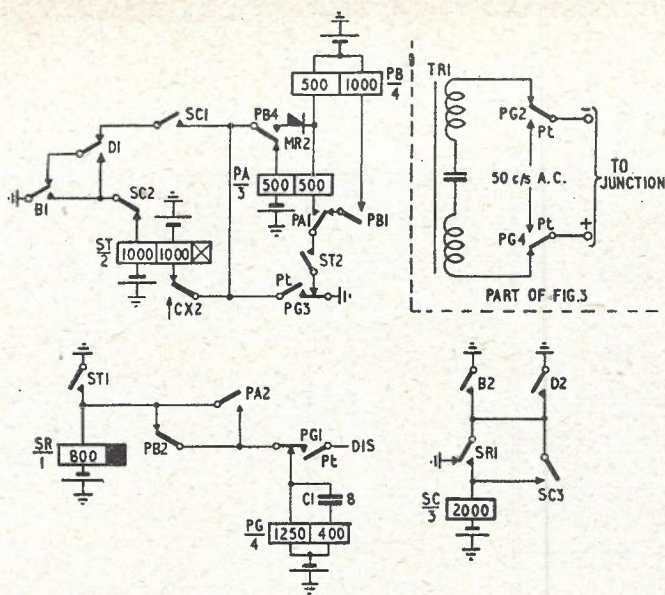

FIG. 4.—FORWARD PULSE SIGNALLING CIRCUIT ELEMENTS.

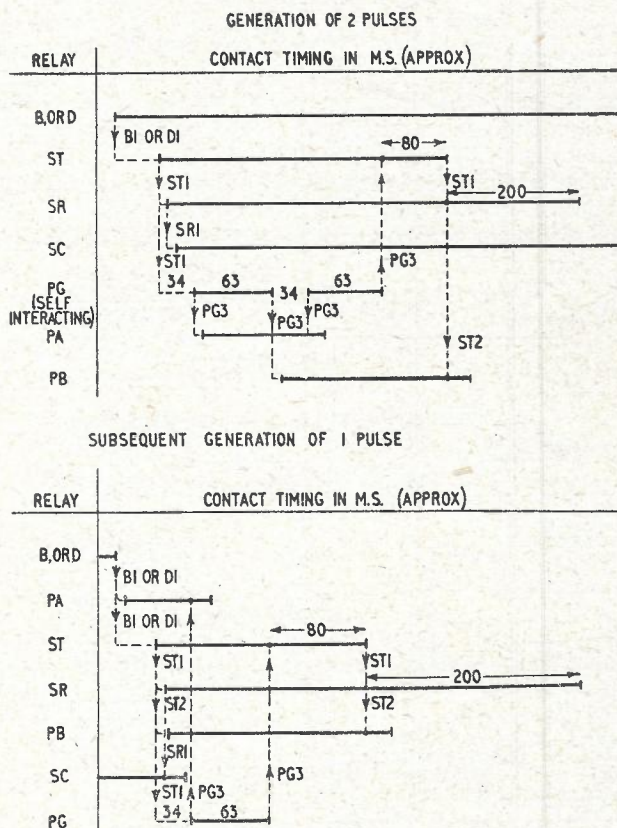

FIG. 5.—RELAY SEQUENCE OF FORWARD PULSE GENERATION.

indicate that the condition has been signalled. Likewise, the release of relay D when the called subscriber clears, results in the generation of one pulse and the release of relay SC. The function of the counting relays, i.e. PB operated and PA released, is to prevent further self-interaction of the pulse generating relay PG. Relay ST is made slow-to-operate to absorb possible flicks from relay B, or relay D; its release lag holds the relay operated during the interval between two pulses. The slow release of relay SR (during which further signalling is prevented) allows an adequate fluxing and signalling period for relays in the distant exchange, before they have to accept, or return, the next signal.

Backward Pulse Receiving, Counting and Control.

The reception of short pulse signals is shown in Figs. 6 and 7. The reception of two pulses results in the operation and

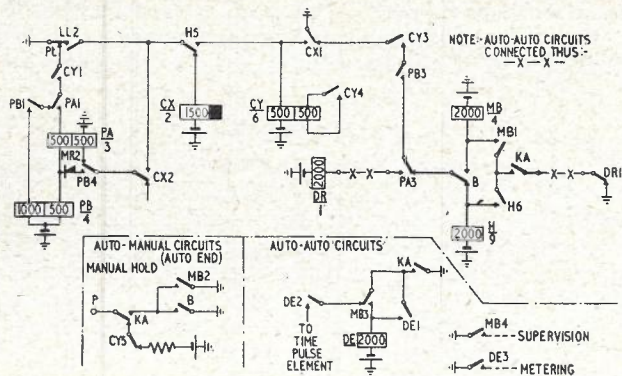

FIG. 6.—BACKWARD PULSE RECEIVING, COUNTING AND CONTROL CIRCUIT ELEMENTS (INCLUDING ANSWERING, SWITCHING AND FLASHING RELAYS.)

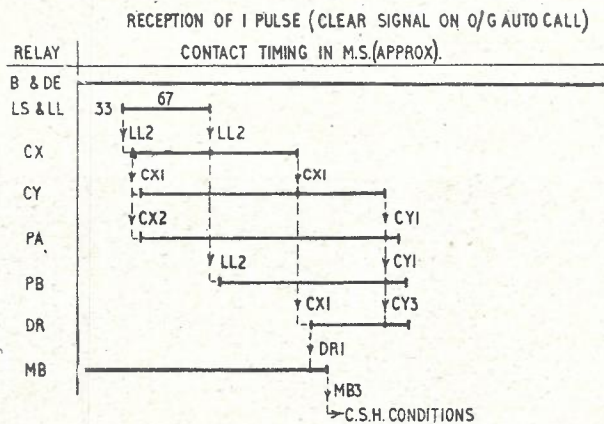
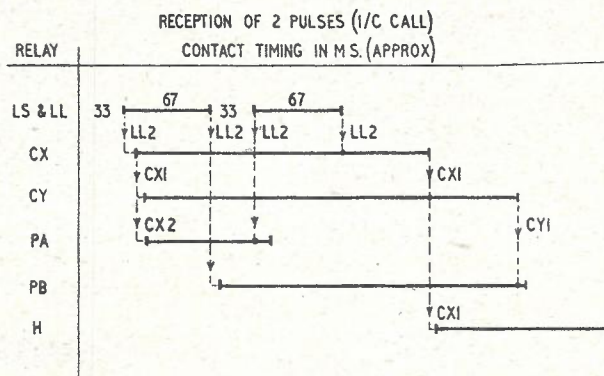

FIG. 7.—RELAY SEQUENCE OF BACKWARD PULSE RECEPTION.

hold of relay H, contacts of which extend the call to a selector and disconnect the counting circuit (at H5) against the subsequent dialled impulses. The reception of two pulses during an outgoing call (relay B operated) results in the operation and hold of the answering relay MB. The reception of one pulse subsequent to the answer signal on an outgoing call results in the operation of relay DR, followed by the release of relay MB and the setting up of C.S.H. conditions. Relay DR is not required at the auto exchange on an auto-manual route. At a tandem U.A.X., however, relay DR facilitates the repetition of supervisory signals on both outgoing and incoming calls, although the circuit

changes necessary for this have not been shown in Fig. 6. Relay DE has been included only to show the continuous answer condition necessary for the metering and time pulse elements on the auto-auto circuits. The counting circuit at a manual exchange has not been shown, but it is very similar to Fig. 6; relay H actuates the calling signal on an incoming call and subsequently, in conjunction with relay DR, controls the supervisory signals in the cord circuit; on outgoing calls the supervisory signals are controlled by relays MB and DR.

Impulsing Aids.

The impulsing aids are shown in Fig. 8. On auto-auto routes the impulse regenerator is used on incoming calls to

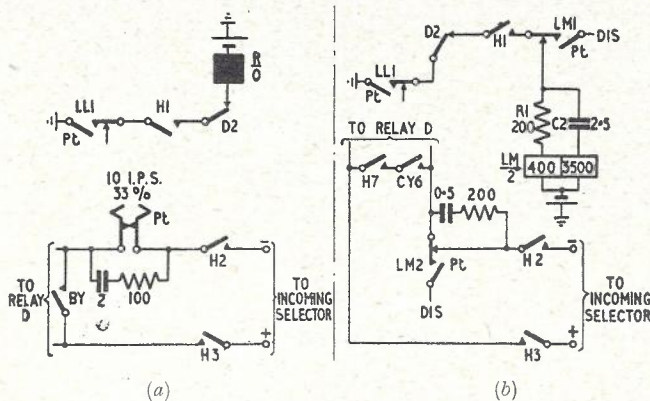
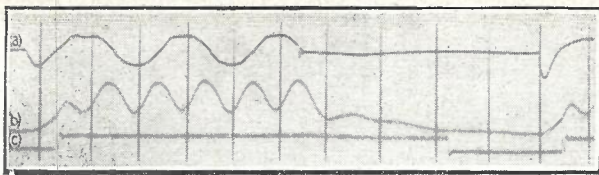

FIG. 8.—IMPULSING AIDS. (a) REGENERATOR CONNECTIONS USED IN U.A.X. AUTO-AUTO RELAY SETS. (b) "FIXED BREAK" CORRECTOR USED IN U.A.X. RELAY SETS FOR JUNCTIONS INCOMING FROM A MANUAL EXCHANGE.

correct distortion of received impulses caused by the system (this is explained later). The BY contact, operated whilst the regenerator is off-normal, provides the impulsing loop. Following the reception and retransmission of the impulses, the answer condition, i.e. D2 operated, disconnects the regenerator for the remainder of the call. On calls direct from a manual exchange, distortion of the received impulses at the U.A.X. is partially corrected by passing the impulses through a fixed "break" corrector. This is the self-interacting relay LM, which is designed to have an output of 70 per cent. break at 12.5 i.p.s., i.e. 57 ms—each dialled pulse received releases a fixed break pulse of 57 ms; the corresponding make pulses vary according to the dial speed. This duration of break pulse in conjunction with the 9-11 i.p.s. limits of an operator's dial, allows operation over one subsequent D.C. junction, e.g. from a Unit No. 13 minor exchange to a dependent U.A.X. No. 12, without additional impulsing aids. On incoming calls following the seizure signal, LL1 operating and releasing to the received impulses triggers relay LM, while H7 and CY6 provide the impulsing loop for LM2; subsequently, on receipt of the answer condition, D2 disconnects the corrector circuit for the remainder of the call.

DISTORTION AND CORRECTION OF 50 c/s A.C. PULSES

Distortion of the pulses takes place at both the sending and receiving ends of a junction. That at the sending end is due to the random phase at which the 50 c/s wave form is cut (by the impulsing source) to form the signal pulse. This results in a random variation of pulse length of up to ± 6 per cent., which, however, is greatly reduced when the dial speed varies 2 per cent. or more from the critical speed. The distortion of the pulse length at the receiving end of a junction can be seen in Fig. 9, which is an oscillogram of a receiving element in adverse adjustment. It shows the



(a) Received 50 c/s A.C. Line Current.
(b) Rectified Pulse Through Relay LS.
(c) Output from Relay LS.

FIG. 9.—OSCILLOGRAM SHOWING PULSE DISTORTION, WITH:—SENDING END SOURCE OF 50 c/s A.C. 75V; IMPULSES AT 10 I.P.S.; PULSE LENGTH = 55 PER CENT.; SHORT JUNCTION; RECEIVING RELAY LS IN LIGHT ADJUSTMENT; DISTORTION = 22 PER CENT. (APPROXIMATELY).

increase of pulse length (about 20 per cent.) due to the slugging effect of the rectifying components which are effectively in shunt with the receiving relay LS (see Fig. 3). To overcome the distortion problems encountered it has been found convenient to modify the pulse ratio of impulsing at the outgoing end from the usual 67/33 to approximately 54/46, by using the auxiliary rather than the normal impulsing springs of the regenerator. This ensures a make pulse, i.e. magnet de-energisation time of at least 20 mS into the incoming end regenerator. This regenerator has a normal 67/33 loop-disconnect output to the succeeding selector. In

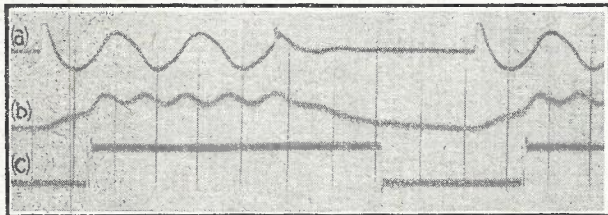

(a) Received 50 c/s A.C. Line Current.
(b) Rectified Pulse through Relay LS.
(c) Output from Relay LS.

FIG. 10.—OSCILLOGRAM SHOWING COMBINED EFFECT OF DECREASING THE PULSE LENGTH AND LIMITING SENDING END 50 c/s A.C. TO 40V, WITH:—IMPULSES AT 10.1 I.P.S.; PULSE LENGTH = 54 PER CENT.; DISTORTION = 12 PER CENT. (APPROXIMATELY).

Book Review

"Filter Design Data." J. H. Mole, Ph.D., A.C.G.I., D.I.C., A.M.I.E.E. E. & F. N. Spon Ltd., London. 252 pp., 127 figs. and charts, 56 tables. 63s.

This volume is intended as a handbook for use by the general engineer in the day-to-day design of conventional ladder filters. The author claims, perhaps a little unjustly, that existing text-books are too much concerned with the theory and too little with the practical design of filters, and so has prepared this book to remedy the deficiency. Realising that the majority of engineers will have little time or patience to digest, even in handbook form, the more advanced aspects of modern network theory, he has restricted the scope to ladder filters comprising matched sections and designed via the image-parameter theory. The more general forms and treatment of the image-parameter theory introduced by Cauer and Bode in the thirties, lattice networks and their differential equivalents, and the insertion-loss theory which is now gaining in popularity, are all omitted. Nevertheless, as these topics lie mainly in the province of the network specialist, their omission is not serious and will probably widen the appeal.

With only a very elementary grounding in filter theory the engineering reader should quickly be able to grasp the practical steps necessary in a design. Following an introductory chapter, which outlines most of these points, are three chapters, one dealing with low-pass filters, together with those derivable from them by reactance transformations, one dealing with dissymmetrical band-filters and one dealing with impedance

addition, the current to the receiving relay has been limited by restricting the sending end 50 c/s A.C. source to 40V, together with a compensatory increase in the value of the smoothing capacitor C6 (Fig. 3). The resultant improvement in the output ratio of relay LS is shown in Fig. 10. The modified pulse ratio at a manual exchange on outgoing calls is produced by a biased impulse repetition relay.

CONCLUSIONS

The present use of the system is on overhead junctions between U.A.X.s Nos. 12 and 13, and/or between these U.A.X.s and a parent C.B.S. No. 2, or C.B. exchange; for satisfactory transmission the number of isolating transformers in a junction should not exceed five. The system could also be used on underground circuits, but the signalling limit is approximately the same as for generator signalling, i.e. 26 miles, and then only by raising the 50 c/s sending source to 70V.

Although the first use of this system has been described using 50 c/s A.C. for signalling, other cases arise in carrier and radio working, where D.C. signals are used between the exchange and the transmission equipment. The D.C. signals are required to provide simple ON/OFF signalling facilities in each direction over the transmission path, which can be satisfied by pulse signals. The system is therefore suitable for use with radio links in which the carrier is keyed on and off for signalling.³ Where carrier or radio equipment has no "built-in" signalling facilities, M.C.V.F. telegraph equipment may be associated to provide the means of signalling. To give these additional facilities, strappings have been provided in the S.S. A.C. No. 5X relay sets to suit the various signalling conditions which may be required.

ACKNOWLEDGMENT

The author is grateful for the advice and help given by his colleagues in the preparation of this article.

³ *P.O.E.E.J.*, Vol. 44, p. 66.

transformations in band-filters. These chapters give all the relevant formulæ for obtaining the image parameters and element values of the networks considered. Except for the last chapter the remainder of the book is mainly concerned with the correct choice of the image parameters to meet prescribed insertion-loss requirements. One fairly lengthy chapter is devoted to the effect of tolerances on components. Everywhere there are copious curves and tables of nearly all the functions required in practice and these should make it simple for the newcomer to the subject to appreciate the relative significance of the different parameters.

It is rather strange that no mention is made of the use of templates for selecting the image attenuation function. These templates, which are now in almost universal use, were devised over 10 years ago by Laurent and Rumpelt, and constituted one of the few great discoveries in design technique. It is a feature of the book that the very problem which these templates solve so neatly, that of choosing the m -values for a complicated filter, is somewhat evaded. One is left wondering how, if ever, the author himself dealt with the cases other than the one of a uniform stop-band requirement which he treats so fully. The fact that the 60-odd curves in Figs. 9 and 10 become all identical and equal to the template curve by merely making the m -scale logarithmic suggests that the author has not realised their significance.

The last chapter is concerned with a direct insertion-loss treatment of very simple structures, e.g., coupled tuned circuits.

H. J. O.

A New Cable-Fault Indicator

M. B. WILLIAMS, B.Sc. (Eng.), A.M.I.E.E.
and D. BROOKES, Graduate I.E.E.†

U.D.C. 621.317.333.4: 621.315.212

This article describes a sensitive cable-fault indicator developed for monitoring the insulation resistance on an interstice pair test circuit in a coaxial cable. The basic circuit arrangement includes a form of Wheatstone bridge which is normally unbalanced. When the insulation resistance of the test pair falls below the value at which the indicator has been set to operate, the bridge becomes effectively balanced and an alarm operates if this balanced condition continues for a period exceeding approximately 10 minutes.

INTRODUCTION

CONTINUOUS maintenance effort is directed towards maintaining a high standard of insulation resistance on the cables forming the main Post Office underground network. It is possible to increase the insulation resistance on cable pairs far above the value determined from considerations of transmission loss alone. It is desirable to attain such a high standard, since given regular routine testing, a dielectric fault producing a fall in the insulation resistance will be detected before the transmission circuits carried in the cable are affected, and standard methods for locating such a fault in the incipient stage (i.e. when the fault resistance exceeds say 50 megohms) may be applied with good chance of avoiding complete failure, loss of service and unnecessary replacement of cable lengths.

Manual testing by means of an ohmmeter is time-consuming, and it is rarely practicable to test each cable more frequently than once per day, so that a cable fault may not be detected until the condition of the cable has deteriorated sufficiently to affect the circuits it carries.

It is natural, therefore, that much thought has been directed to the possibility of automatically monitoring or testing sample wires in such a way that an alarm would be given when the insulation resistance falls below a prescribed minimum value. Such devices are used on short cables in the junction networks in London and Liverpool. An experimental fault indicator for carrier cables was installed on the Bristol-Plymouth carrier cable in 1938, but its field trial was abandoned after the outbreak of war. Its design, however, inspired the development of a simple insulation indicator provided for an interstice pair on each coaxial line link. Existing models were designed to detect faults not exceeding 50 megohms, and it is necessary to introduce a more sensitive cable-fault indicator. Preliminary consideration showed that different approaches would probably be needed for audio, carrier and coaxial-pair cables due partly to the different terminating conditions and partly to the different means necessary to make available metallic test circuits. It was decided to begin with the application of sensitive fault indicators to coaxial-pair cables since such a facility is urgently needed to protect the high-frequency systems using these cables and a testing circuit is always available on an interstice pair. Arrangements have already been made to enclose and desiccate the test tablets at intermediate stations on which the interstice pairs are terminated.

A performance specification was drawn up for this application and the Indicator, Cable-Fault No. 1A, has been developed accordingly.

GENERAL REQUIREMENTS

The most important requirements in the design of a cable insulation indicator are reliability and accuracy. It is to be expected that it would have to operate and give an alarm of cable failure at very infrequent intervals, but sufficient confidence should be felt to justify taking immediate action whenever an alarm is received even if it is

outside normal hours of duty. Such confidence would be quickly destroyed if a proportion of alarms proved to be false, or alternatively if an alarm was not given when a genuine fault existed. Thus every care must be taken to prevent false alarms being given from any cause and to ensure reliable operation to genuine faults within the specified performance limits. As a positive contribution towards encouraging confidence, it was decided that the cable insulation indicator should be arranged to permit measurement of the actual insulation resistance of the test circuit at any time, in addition to its chief function of giving an alarm at a set value. This facility would enable regular checks to be made both of the cable and the functioning of the indicator and would supplement, or perhaps even replace, routine measurements now made with an ohmmeter.

Facilities.

It was decided that a cable-fault indicator would be connected to an interstice pair circuit having a route length not exceeding 150 wire-miles. Its sensitivity and discrimination should be sufficient for giving an alarm of cable failure when the wire-to-earth insulation resistance of the circuit under test falls to 250 megohms or half the normal value, whichever should be lower. The 250 megohm limit would apply to a short cable circuit where the normal distributed insulation resistance of a single pair would be expected to be well above 500 megohms and the alarm condition would correspond to a fault resistance of at least 250 megohms.

A test circuit on an interstice pair in a coaxial pair cable is routed through U-links at terminal and intermediate stations; on a 150 wire-mile circuit there will be about 30 such U-link connections. To guard against the possibility of the cable indicator being made ineffective by the accidental disconnection of the test pair at some intermediate point along the line, it was required that an alarm would be given if such a disconnection occurred.

The cable fault indicator was required to be immune to transient disturbances on the test circuit, such as would be caused by accidental momentary contact or earth faults produced by working parties, or to variations or temporary failure of the power supplies. The unbalanced (i.e., wire-to-earth) circuit would be liable to mains induction and other spurious voltages, particularly where the coaxial pairs were used for power-feeding, and the effect of such interference must be minimised.

Immunity to transient faults and interruptions can be achieved by the use of a time delay circuit which delays giving the station alarm until the fault condition has persisted for 10 minutes. Such delay is sufficient to allow the longest cable circuit to charge up from the fully discharged state.

The unit was required to be self-contained with its own mains power supply unit, and to mount on the standard 19-in. rack.

† The authors are, respectively, Senior Executive Engineer and Assistant Engineer, Transmission and Main Lines Branch, E.-in-C.'s Office.

PRINCIPLE OF OPERATION

As shown in the explanatory diagram Fig. 1, the cable-fault indicator is arranged to measure wire-to-earth insulation resistance (I.R.) in terms of the P.D. produced in a reference resistor by the leakage current from a 300V

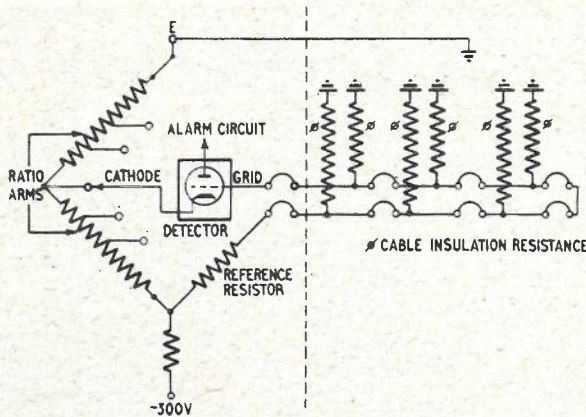

FIG. 1.—EXPLANATORY DIAGRAM OF CABLE-FAULT INDICATOR.

testing supply flowing to earth through the insulation resistance of the line. This P.D. is backed-off by part of the testing supply obtained from variable ratio-arms. This arrangement actually forms a Wheatstone bridge network and the unbalance voltage is applied to a detector which controls an alarm circuit. The variable ratio-arms are adjustable in 12 steps by means of a selector switch, each position corresponding to a particular value of insulation resistance. On any setting, e.g. 200 megohms, as the cable insulation resistance falls from a value above this figure, the unbalance P.D. applied to the detector falls, and

consequently the potential of the detector grid relative to its cathode rises from a very negative value to zero (approx.) when the I.R. falls below 200 megohms. The flow of forward grid-current prevents any further rise in the potential of the grid when the I.R. falls below 200 megohms. The detector is arranged to initiate the operation of the alarm circuit when the unbalance P.D. falls to 1V, i.e., when the Wheatstone bridge is near balance. The delay feature of the alarm circuit is explained later.

CIRCUIT DESCRIPTION

The operation of the indicator circuit (Fig. 2) is most conveniently considered in three sections.

Wheatstone Bridge Network.

The Wheatstone bridge network is formed by the 10-megohm feed resistor R11, the insulation resistance of the test circuit to earth, and variable ratio arms (R12-R24). A 300V testing supply is applied between earth and the feed resistor R11 and the unbalance P.D. is applied to the detector. Each setting of the variable ratio arms is designed to correspond with one of eleven values of insulation resistance between 10 and 700 megohms which will give a specified unbalance voltage at the detector, approximately 1V, and the measurement accuracy is negligibly affected by changes from the nominal value of the 300V testing supply. The resistors used in the bridge network have been taken from the preferred range and are further subject to selection tolerances. In the worst but unlikely case of all errors adding, there could be an absolute error of 20 per cent. in resistance measurements, but between adjacent steps of the selector switch the errors are not likely to exceed ± 5 per cent.

Accidental contact with the test circuit will not result in a dangerous shock as the current which can be drawn from

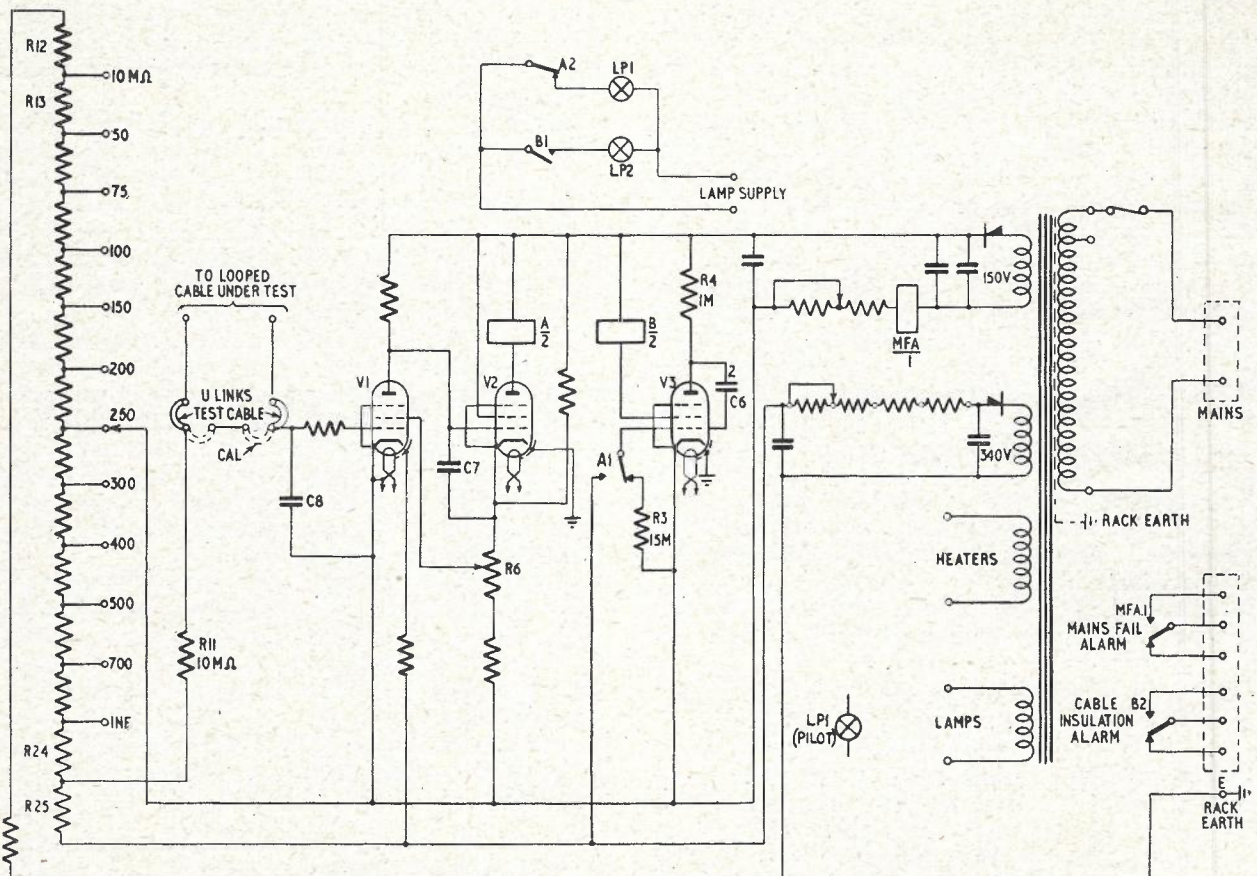

FIG. 2.—SCHEMATIC DIAGRAM OF CABLE-FAULT INDICATOR.

the 300V supply is limited by the 10-megohm resistor R11, to a few microamperes, and the energy stored in the cable capacitance is small.

The connection of the test circuit to the bridge network is arranged as shown in Fig. 1, to provide the desired safeguard against accidental removal of the U-links. The testing supply is applied to one end of the test pair loop and the detector is connected to the other. Removal of any of the intermediate U-links will disconnect the negative supply from the detector which will ultimately reach earth potential and give an alarm.

Detector Circuit.

The detector circuit must respond sharply (ideally having a toggle characteristic) so that a relay can be operated reliably and unambiguously. The input resistance must be very high and the main limitation in using an electronic valve in such an application is the risk of reverse grid-current. The detector circuit was designed, giving first consideration to maintaining a high input resistance. Fig. 3 shows the error which could be produced by grid-

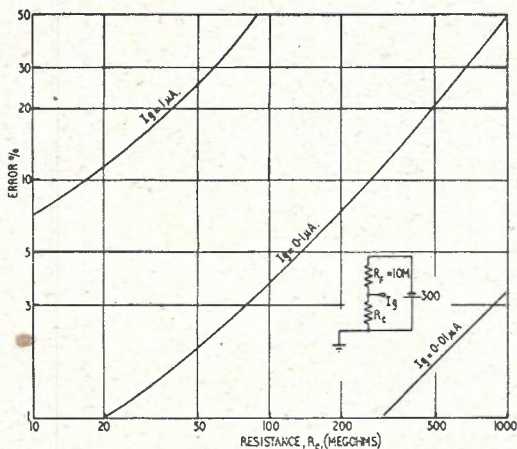

FIG. 3.—GRAPHS SHOWING ERROR IN I.R. MEASUREMENT WHEN DETECTOR VALVE DRAWS REVERSE GRID CURRENT.

current in the measurement of high resistance by the Wheatstone bridge circuit used in the indicator. In practice, however, the test for grid-current (described later) ensures that negligible error is produced from this cause.

The detector found to be most suitable was a two-stage D.C. amplifier stabilised by negative feedback (V1, V2—Fig. 2). The input resistance and output current requirements are incompatible in a single valve. When the insulation resistance of the test circuit is greater than the value to which the selector switch is set, the grid of V1 is negatively biased, the grid of V2 is held at cathode potential by the flow of V2 grid-current, and maximum anode current flows in V2. Relay A is thus normally operated. If the insulation resistance of the test circuit falls, or alternatively if the selector switch is rotated to a position corresponding to a value of the insulation resistance greater than that of the test circuit at the time, the bias on the control-grid of V1 may reach the value (approximately 1V) which causes the anode current of V2 to fall to zero and so release relay A. The CABLE CHARGING lamp LP1 then glows.

In the amplifier, V1 is a high-gain voltage amplifier operating with very low anode current, low anode voltage and with reduced heater power so that reverse grid-current is made a negligible fraction of its value under normal operating conditions. V2 is directly coupled to V1, and its anode current operates relay A. Negative feedback over the two stages is derived in a simple way, similar to that suggested by Volkers,¹ by connecting the screen of V1

to a tapping on a potentiometer which carries also the cathode current of V2. The overall transfer conductance of the amplifier at the operate point of the relay is about 15 mA/V. The transfer conductance without feedback is very large and has not been measured with any degree of accuracy. The "overlap" of the detector, i.e., the difference in the values of V_{g1} of V1 at which the relay operates and releases is about 0.2 volts as shown by Fig. 4; this is

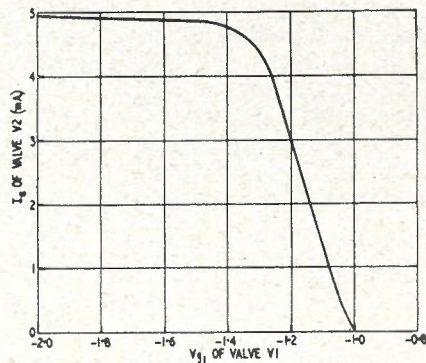

FIG. 4.—TRANSFER CHARACTERISTIC OF STABILISED D.C. AMPLIFIER.

negligible and gives a satisfactory approximation to the desired toggle characteristic so that the detector operation is substantially unaffected by variation in relay adjustment.

A small variation in the operating point of the detector is provided by the potentiometer R6 which varies the screen potential of V1. The detector is set up against a known P.D. in R24 (approximately 1V) by setting the rotary switch to INFINITY, the U-links to CALIBRATE and adjusting R6 so that relay A just releases. The circuit changes made with the U-links convert the bridge network into a simple potentiometer, the detector being connected directly across R24. The feed resistor R11 then acts as a series resistance in the grid circuit and has no effect unless grid-current flows. The variation of screen potential caused by adjustment of the potentiometer R6 varies the value of V1 grid potential required to cause the release of relay A in the anode circuit of V2. The working conditions of V1 are chosen so as to permit the initial setting up to be made with all normal valves.

It is desirable, and fortunately easily possible, to check that a valve fitted in the V1 position of the amplifier is sufficiently free from reverse grid-current under operating conditions. Normally any valve which will pass the appropriate specification should be sufficiently free from grid-current to operate satisfactorily, but faulty valves may be met in the field. The test may be made by setting up, first, as described in the previous paragraph and again with the feed resistor R11 short-circuited by means of a suitable clip lead. There should be no appreciable change in the setting of the potentiometer R6 for the two tests (1/10 of the total rotation of R6 would represent reverse grid-current of about 0.003 microamps).

Since the D.C. amplifier is stabilised by negative feedback the detector is little affected by changes in supply voltages. For a change of 20 per cent. in mains supply voltage to the power unit the change in the value of the V1 grid voltage at which relay A releases is less than 0.1 volts.

The capacitors C8 and C7 are included in the grid circuits of V1 and V2, to reduce the sensitivity of the detector to alternating voltages. As Fig. 4 shows, the detector is linear only over a very narrow range of V1 grid voltage. Consequently, an appreciable alternating voltage appearing at the

¹ Volkers, W. K., *Electronics*, Vol. 24, No. 3, p. 126 (March, 1951).

input, in addition to the direct unbalance voltage, will produce current pulses in V2 and so will change the operate point of the detector.

Delay Circuit.

A delay circuit having certain novel features was developed to prevent false alarms being given on the momentary release of relay A, owing to inductive or other disturbances on the test circuit. The circuit delays giving a cable-failure alarm until the condition has persisted continuously for about 10 minutes. The simple delay circuit used is an application of the "Miller Integrator" and comprises V3, relay B, timing circuit R3, C6 and associated components. Relay B is in the screen supply circuit of V3 and being of relatively low resistance has little effect on the screen voltage. V3, having a high anode load resistance ($R4 = 1$ megohm) then behaves as a high-gain pentode voltage-amplifier. If the potential of the control grid is varied from cut-off to zero, V_a will fall from the supply voltage to nearly zero, V_{g2} will remain constant and I_{g2} will rise from zero to a relatively large value sufficient to operate relay B. Because a change in the potential of the control-grid is amplified and produces a much larger change of potential at the anode, the effective time-constant of the circuit R3, C6 with the capacitor connected between grid and anode, is similarly greater than the time-constant would be if the capacitor were connected between grid and cathode.

The action of the circuit in detail, is as follows. V3 is normally cut-off via contact A1 (operated) by the P.D. (say, V_0) in R24 and R25 and any portion of the resistance chain R13 to R25 which is connected by the selector switch. Under this condition no current flows in anode or screen circuits and relay B is released, the anode potential V_a is equal to the supply voltage $V_{a(b)}$, and the timing capacitor C6 is charged to a P.D. = $V_{a(b)} + V_0$. When relay A releases A1 connects the grid to cathode via the timing resistor R3, C6 begins to discharge and the anode potential V_a , after an initial rise by V_0 falls steadily at a rate determined mainly by the time-constant CR . The final value of V_a and thus of the P.D. across C6, is nearly zero, since the screen potential is high and the anode load is large. During the anode run-down the interconnection between grid and anode circuits via C6 holds V_{g1} near cut-off by the C6 discharge current flowing in the grid resistor R3 and thus a negligible screen current flows. Towards the end of the run-down, as V_a approaches zero, the amplifier gain falls rapidly, V_{g1} is no longer held near cut-off and rapidly becomes zero. Screen current then flows and operates relay B. B2 extends the main alarm and B1 lights the CABLE FAILURE lamp LP2.

During the timing period T seconds, say, the P.D. across the capacitor C6 (capacitance C) falls from its initial value ($V_{a(b)} + V_0$) to zero (approximately), hence if the loss of charge is Q , then

$$Q = \{V_{a(b)} + V_0\} \cdot C \dots\dots\dots(1)$$

The discharge current, i_c , flows through the grid resistor R3 (resistance R) and produces the grid voltage V_{g1} and thus,

$$V_{g1} = R \cdot i_c \dots\dots\dots(2)$$

Now the total loss of charge is given also by,

$$Q = \int_0^T i_c dt \dots\dots\dots(3)$$

$$= \frac{1}{R} \int_0^T V_{g1} dt \quad (\text{from } 2)$$

$$= \frac{\overline{V_{g1}}}{R} \cdot \frac{1}{T}$$

(if $\overline{V_{g1}}$ is the mean value of V_{g1} during the timing period T .)

$$= (V_{a(b)} + V_0) C \quad (\text{from } 1)$$

$$\text{Then, } T = \frac{(V_{a(b)} + V_0) CR}{\overline{V_{g1}}} \text{ secs.}$$

Although $\overline{V_{g1}}$ is approximately equal to the cut-off bias, it depends on V_a and V_0 (and so varies with the setting of the selector switch) but it is found that the time delay is substantially a constant multiple of CR . With the circuit used, the time delay is approximately $20 CR$ so that with $C = 2$ microfarads and $R = 15$ megohms the delay is 10 minutes. It is thus possible to obtain a long delay without using an inconveniently large capacitor or resistor; the insulation resistance of the timing capacitor is, however, proportionally more important.

A particular feature of this delay circuit is that premature operation of the alarm relay is prevented by the trigger characteristic given to the screen current, which is nearly zero for about 80 per cent. of the timing period and then rapidly rises to its final value as is shown in Fig. 5. The

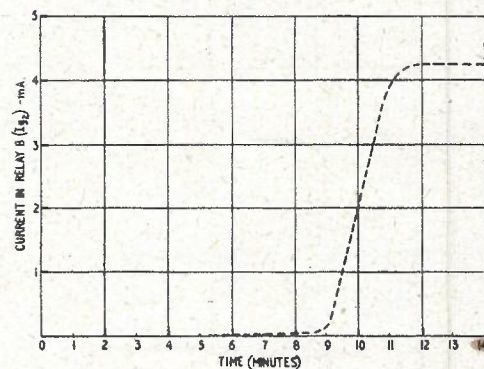

FIG. 5.—SCREEN CURRENT/TIME CHARACTERISTIC OF DELAY CIRCUIT.

restoration time of the circuit is much less than its operating time, consequently it will not integrate a succession of impulses each less than the required delay time. The time delay is practically independent of normal variations in supply voltage or normal valve replacements.

Power Supplies.

A small self-contained power unit gives two isolated H.T. supplies for the bridge circuit and the detector together with heater and lamp supply. The anode supply for the detector and delay circuits is nominally 105V at 15 mA. The testing voltage for the bridge is nominally 300V at 3 mA. Both these H.T. supplies are derived from simple half-wave rectifiers with capacitor-resistor smoothing. No attempt is made to stabilise the power supplies since the Wheatstone-bridge circuit, the detector, and the delay circuit, are substantially independent of variations in voltage. However, when it is desired to use the indicator to give direct readings of insulation resistance a regulated mains supply is an advantage. While the mains supply is changing a charging or discharging current will flow through the feed resistor and would give a lower or higher apparent insulation resistance. Such errors may be eliminated in practice by making a few observations of the indicator setting separated by a minute or two.

CALIBRATION AND ADJUSTMENT

The two wires of the test circuit are cabled in polythene-insulated, twin, screened cable to the U-link sockets on the small sub-panel of the indicator. The screen of this cable is earthed to reduce interference from A.C. supplies. A

preliminary adjustment is made as follows (see Fig. 2):—

With the U-links set to CALIBRATE and the selector switch set to INFINITY, the amplifier sensitivity is adjusted by the potentiometer R6 until the CABLE CHARGING lamp LP1 glows indicating the release of relay A; after a time delay of 8-12 minutes, the CABLE FAILURE lamp LP2 should glow.

To bring the indicator into use, the U-links are put in the TEST CABLE position, and the cable begins to charge up to a P.D. determined by its insulation resistance. After a few minutes the actual value of the insulation resistance can be determined by rotating the selector switch until the CABLE CHARGING lamp is extinguished, when the cable insulation resistance will be between the indicated value and the next higher value. This can be done at any subsequent time without waiting for the cable to charge, since the operation of the indicator does not discharge the cable.

The switch may then be set to a suitable lower value and an alarm will be given if the insulation resistance falls below this figure.

CONSTRUCTION

The indicator is built on a 19-in. by 5¼-in. skeleton panel, all the components except the mains transformer being mounted on an insulated sub-panel; this method of construction suits the high working voltage and the need for good insulation. The parts requiring the highest insulation are those associated with the test pair and the input to the detector; these are carried on a small sub-panel of material having a high surface resistivity (e.g., polystyrene). The 12-position selector switch which adjusts the sensitivity of the indicator so that it will operate on any one of 12 values of insulation resistance is mounted so that its knob protrudes through the panel dust cover. Fig. 6 shows the construction

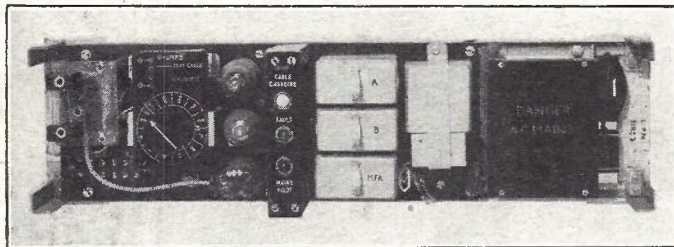

FIG. 6.—PROTOTYPE INDICATOR—COVER REMOVED.

of one of the three prototype models which were made for field trial, and which differ in minor details only from the final design.

FIELD TRIALS

Experimental models of the cable-fault indicator are being given field trials on a number of coaxial cables. An indicator has been installed at Bristol and connected to 90 wire-miles of interstice pair on the Bristol-Kidderminster cable; another indicator has been fitted at Colwyn Bay and connected to 88 wire-miles on the Colwyn Bay-Holyhead cable; and an early model of the indicator was installed in the Main Lines Branch Laboratory and connected via a tie cable to an interstice pair routed over part of the London-St. Margaret's Bay No. 4 cable.

The prototype indicators have given satisfactory performance during these trials; a number of cable faults have been detected in their early stages and no false alarms have been reported. Removal of U-links at intermediate stations on a number of occasions has been correctly brought to notice. Frequent measurement of cable insulation resistance

has been made with the indicator and showed good agreement with ohmmeter measurements when these were made.

Fig. 7 shows a 3-month record of daily indicator readings

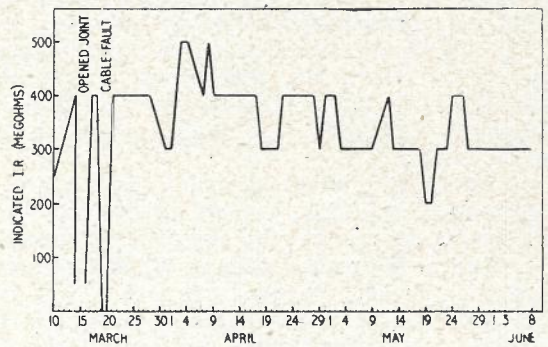

FIG. 7.—INDICATOR READINGS (DAILY) AT BRISTOL R.S. ON BRISTOL-FALFIELD (30 WIRE-MILES) SECTION OF BRISTOL-KIDDERMINSTER CABLE.

of insulation resistance made on a short section (30 wire-miles, 3 intermediate stations) of the Bristol-Kidderminster coaxial cable. This diagram shows consistently high insulation resistance, averaging about 350 megohms (i.e., 10,500 megohms per wire-mile). Two alarms were given by the indicator during this period, one due to the application of heat to a joint and the other due to a corrosion fault.

Fig. 8 shows the subsequent 3-month record of daily

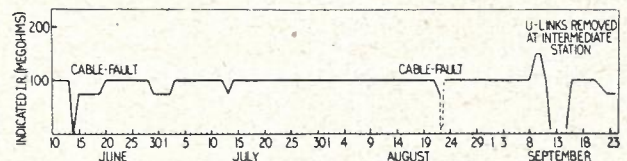

FIG. 8.—AS FOR FIG. 7 BUT ON BRISTOL-TEWKESBURY (90 WIRE-MILES) SECTION.

readings of insulation resistance after the test circuit had been extended to 90 wire-miles. The average value of measured insulation resistance was naturally somewhat lower, about 100 megohms, but even so, corresponded to a distributed insulation resistance of about 9,000 megohms per wire-mile. Three alarms were given during this period, two from cable faults and one due to accidental removal of U-links at an intermediate station. One of the cable faults developed so rapidly that the system supervisory circuits were affected before the 10 minute time-delay of the indicator had expired.

Fig. 9 shows a three-month record of indicator readings

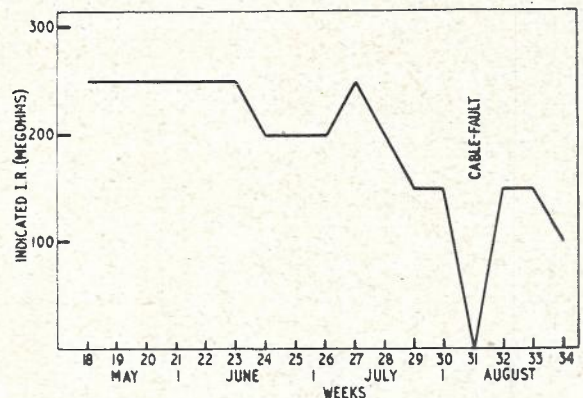

FIG. 9.—INDICATOR READINGS (WEEKLY) AT COLWYN BAY R.S. ON COLWYN BAY-HOLYHEAD CABLE (88 WIRE-MILES).

for a test-pair on the Colwyn Bay-Holyhead cable (88 wire-miles). Very high values of insulation resistance were recorded for this cable, the measured values of 200 megohms corresponding to a distributed insulation resistance of 18,000 megohms per wire-mile. Two alarms were given by the indicator during this period, at the onset and during the clearing of a corrosion fault. Two alarms of cable failure were satisfactorily given during the two months previous to the beginning of this record, and three given during two subsequent months.

It was mentioned earlier that a wire-to-earth test circuit, being unbalanced, was liable to interference, and spurious voltages would appear at the detector by unbalanced power feeding on the coaxial pairs or by leakage currents from electric traction systems. The test-circuit on an interstice pair in the London-St. Margaret's Bay No. 4 cable suffered from considerable interference apparently from both these causes and contained a steady mains frequency A.C. component, and a fluctuating D.C. component. The recorder traces in Fig. 10 showed the difference

fluctuations could well be due to electric railways. The mains frequency (A.C.) component remained steady at all times and was about 2V R.M.S.; this was undoubtedly due to the use of the coaxial pairs for power feeding.

The A.C. component will not affect the detector unless of excessive magnitude, since the detector has been made fairly insensitive to such signals, and impulses or fluctuations of the D.C. component are made ineffective by the introduction of the time delay circuit. A steady D.C. component will, however, produce an error in this or any similar method of measuring resistance. Supposing the measured voltages (about 2V positive-to-earth) are still present when the testing supply is applied, the current, 0.2 microamp. produced in the 10-megohm feed resistor will appear as though caused by a leakage resistance of 1,500 megohms. The measurement error produced would vary between the appreciable value of +25 per cent. when measuring 500 megohms, to a negligible error of +3 per cent. when measuring 50 megohms. There is then little point in such circumstances, in attempting to measure insulation resistance much in excess of 500 megohms or in taking account of small variations in such values.

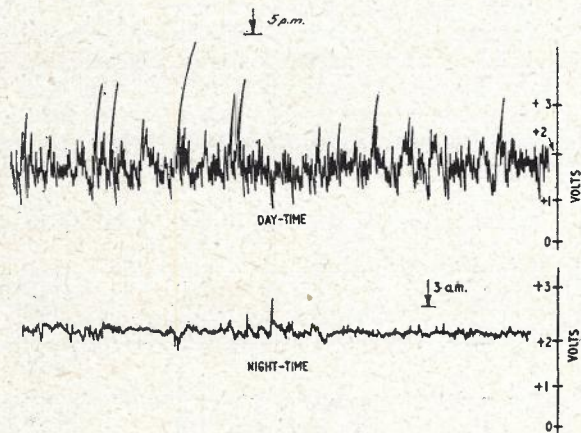

FIG. 10.—RECORDER TRACES SHOWING D.C. INDUCTION ON CABLE TEST CIRCUIT IN LONDON-ST. MARGARETS BAY NO. 3 CABLE (L-CU LOOP). MEASURED AS P.D. ACROSS 10MΩ RESISTOR BETWEEN LOOPED PAIR AND EARTH.

between the unidirectional component obtained during the day-time and that obtained during the early hours after midnight. The mean value was roughly constant, about +2V at the detector grid, but there were violent fluctuations during the day which were not present at night. These

CONCLUSIONS

The Indicator, Cable-Fault No. 1A has been introduced for automatically monitoring the insulation resistance of a long test circuit on an interstice pair on a coaxial cable, and it may also be used for routine tests. Field trials have been promising and it may be found possible to extend its field of application to other types of cable. Before this can be done it will probably be necessary to improve the insulation resistance of cable terminating apparatus, and, in the case of audio cable to find some way of using working circuits without interfering with their normal function.

To obtain maximum benefit from cable-insulation tests, whether by manual routine tests or by an automatic indicator, requires that the highest possible standard of insulation is maintained normally, and is restored immediately a fault is cleared so that an incipient fault produces a significant fall in the measured insulation resistance.

ACKNOWLEDGMENTS

Acknowledgments for assistance are due to the members of the Cable Maintenance Group, LM4/1, in particular Messrs. G. E. Rossiter and R. J. Griffiths, to members of the staff of LM Branch Laboratory and to maintenance staff at Bristol and Colwyn Bay.

Book Review

"Electrical Instruments and Measurements." W. Alexander, M.Sc., B.Sc.(Eng.), M.I.E.E. Published by Cleaver-Hume Press, Ltd., in the Cleaver-Hume Electrical Series. 347 pp. 112 diagrams. 12s. 6d.

Without electrical measuring instruments there could be no electrical engineering. All student electrical engineers must study the rudiments of measurement technique, but only the few who enter the specialised avenue of the industry dealing with meter design and construction advance much beyond the study of fundamental principles.

Mr. Alexander, who is a university lecturer in industrial electronics, has collected up-to-date information on the most important types of electrical measuring instruments used in power engineering. He explains the basic principles of the moving coil, moving iron, dynamometer and electrostatic instruments, and, with the help of excellent illustrations provided by well-known manufacturers, describes many of the models that are in everyday use. A chapter of this book is devoted to each class of instrument in turn, e.g., the ammeter and voltmeter, wattmeter, power factor indicator, frequency meter and, in particular, the multi-range type of meter.

Ancillary equipment is also described, such as the current transformer for use in heavy current measurements, and the method of operation is analysed. A useful chapter is that devoted to leakage resistance measuring devices, such as the Megger.

The book is eminently practical. The performance requirements laid down in British Standard Specifications for the various classes of meters are concisely tabulated, and the methods of meter testing and calibrating are described. The concluding chapter gives a brief outline of the measurements necessary in power installation testing.

A set of test questions on each chapter is included for the benefit of students who are reading for the National Certificates in Electrical Engineering or the electrical engineering aspects of the City and Guilds of London Institute examination. Only small demands are made on the mathematical knowledge of the reader, and no knowledge of calculus is assumed. Graphical vector methods are freely used, however, a point on which the author is to be commended.

The book is excellently printed, and is very well illustrated, and it will prove a useful reference work on power measuring instruments for those who do not specialise in this class of work.

C. F. F.

Single-Sideband Multi-Channel Operation of Short-Wave Point-to-Point Radio Links

W. R. H. LOWRY, B.Sc.,
and W. N. GENNA†

Part 3.—An Independent-Sideband Short-Wave Radio Receiver

U.D.C. 621.396.41: 621.396.619.24: 621.396.62.029.58

The design, construction and performance of an "independent-sideband" receiver, suitable for use on long-distance point-to-point radio links in the range 4 to 30 Mc/s, are described. The independent-sideband signal comprises a reduced-level pilot carrier and two 6-kc/s wide sidebands, one being above and the other below the pilot carrier frequency. The present article is Part 3 of a series; earlier articles in the series have given a general survey of the principles of single-sideband multi-channel operation and described the generation of single-sideband signals. Part 4, concluding the series, will deal with an independent-sideband high-power short-wave transmitter.

Introduction.

THE receiver described in this article has been designed for operation on long-distance point-to-point short-wave radio links forming part of the international trunk network. This application demands a high standard of performance from the receiver, particularly in respect of its ability to function satisfactorily under conditions of severe fading, high levels of noise due to adverse propagation conditions, and in the presence of strong unwanted transmissions on frequencies adjacent to the wanted transmission.

The advantages of single-sideband compared with double-sideband operation of short-wave radio links have been described elsewhere¹; from the point of view of reception the most significant advantages are perhaps the reduction of the non-linear distortion which is due to multiple-path propagation and the improvement in the signal-to-noise ratio.

The present receiver has been designed to receive an independent-sideband signal comprising two single-sideband signals, each 6 kc/s wide, one being above and the other below the frequency of a reduced-level pilot carrier.² Each sideband can accommodate two 3 kc/s wide telephony channels or several voice-frequency telegraphy channels. The carrier level is reduced some 26 db. below the peak sideband level in order that nearly all the power output of the transmitter shall be available for the sidebands, thus improving the signal-to-noise ratio.

The receiver can also be used to receive double-sideband transmissions; there are certain advantages in so doing, e.g. the reduction of non-linear distortion due to multiple-path propagation and the possibility of selecting one sideband to avoid interference appearing in the other sideband.

Spaced-aerial diversity operation can be provided by the addition of certain units to the receiver, other units, e.g. oscillators, being used in common.

Schematic Arrangement of Receiver.

The schematic arrangement of the receiver, in its non-diversity form, is shown in Fig. 1. The double-superheterodyne principle has been employed, since it enables an adequate image ratio to be achieved by the use of a high first intermediate frequency (i.f.), whilst effective filtering of the carrier and sideband signals can be best achieved at a low second intermediate frequency. The first i.f. of such a receiver is usually in the range 1-4 Mc/s; a frequency of 3.1 Mc/s has been adopted in this receiver and is identical with the second i.f. in the transmitter drive equipment.² For the most effective and economical designs of sideband and carrier filters using quartz-crystal resonators, the range 50 kc/s-200 kc/s is preferred; a second i.f. of 100 kc/s is suitable and is identical with the first i.f. in the transmitter drive equipment. The sideband filters used in the transmitter drive and receiver are of identical design, performance and construction; this arrangement reduces the number of types of filter required, thus reducing costs and simplifying maintenance.

It is necessary to select the pilot carrier in a filter of relatively narrow bandwidth, so that the carrier may be amplified and used for the automatic gain- and frequency-controls and, if required, for demodulation of the sideband signals to audio frequency. The necessity for deriving the automatic gain-control (a.g.c.) voltage from the filtered and amplified pilot carrier arises from the fact that the sideband energy is intermittent and frequently exceeds the carrier level. The filtered and amplified carrier is applied to a limiter to remove fading and unwanted amplitude modulation before being used for automatic frequency-control (a.f.c.) or demodulation; the carrier so obtained is called the reconditioned carrier.

The necessity for a.f.c. arises mainly from the need to prevent the carrier from being removed from the narrow pass-band of the carrier filter by drifts in frequency of the oscillators in either the transmitter or the receiver. The a.f.c. may be applied to either the first or second oscillator in a double-superheterodyne receiver, the correction being such as to compensate for the drifts in frequency of all the

oscillators in the transmitter and in the receiver. If the control is applied to the second oscillator, as shown in Fig. 1, it is possible to replace the variable (inductor-capacitor) type of first oscillator that is normally provided, by a quartz crystal-controlled oscillator. This is a convenient arrangement for a point-to-point service in which the number of operating frequencies is limited, since it reduces the drift of the first oscillator, avoids sudden frequency changes due to vibration and other causes that may cause loss of frequency control, and

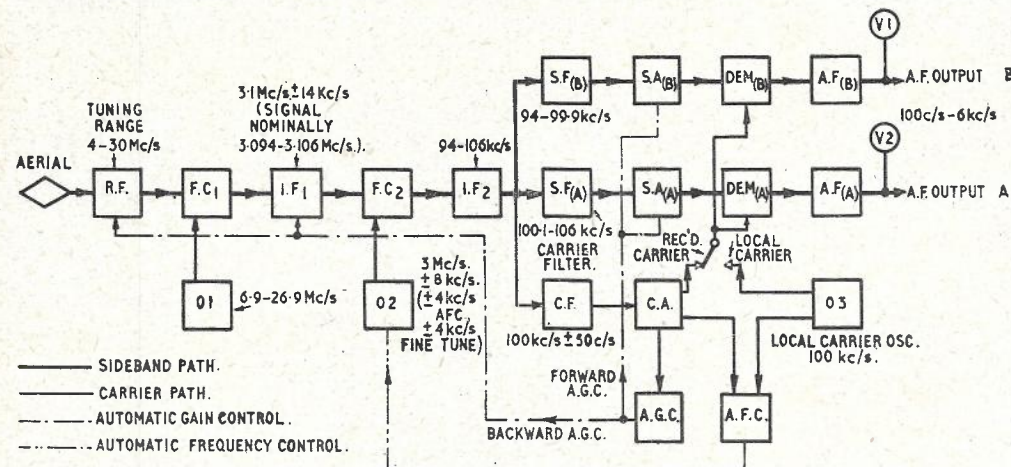

FIG. 1.—SCHEMATIC DIAGRAM OF INDEPENDENT-SIDEBAND RECEIVER.

† The authors are, respectively, Senior Executive Engineer and Assistant Engineer, Radio Experimental and Development Branch, E.-in-C.'s Office.

¹ For References see end of Article.

simplifies the tuning of the receiver by reducing the range of search required.

For the reception of a single-sideband transmission a sideband filter is not essential, but it is usual to provide such a filter to attenuate noise and interfering signals which may occur in the range of frequencies on the side of the carrier opposite to the wanted sideband. By the use of two sideband filters, each accepting one sideband and rejecting the other, outputs corresponding to the upper and lower sidebands of an independent-sideband transmission are obtained.

The standard independent-sideband transmission has sideband A above the carrier frequency when the latter exceeds 10 Mc/s, and below the carrier frequency when it is below 10 Mc/s. It is desirable that the first oscillator in the receiver should be below the carrier frequency when the latter exceeds 10 Mc/s, and above the carrier frequency when it is above 10 Mc/s, in order that a given sideband may always be identified with a given a.f. output from the receiver.

Construction and Layout.

Fig. 2 shows the receiver mounted on one side of each of

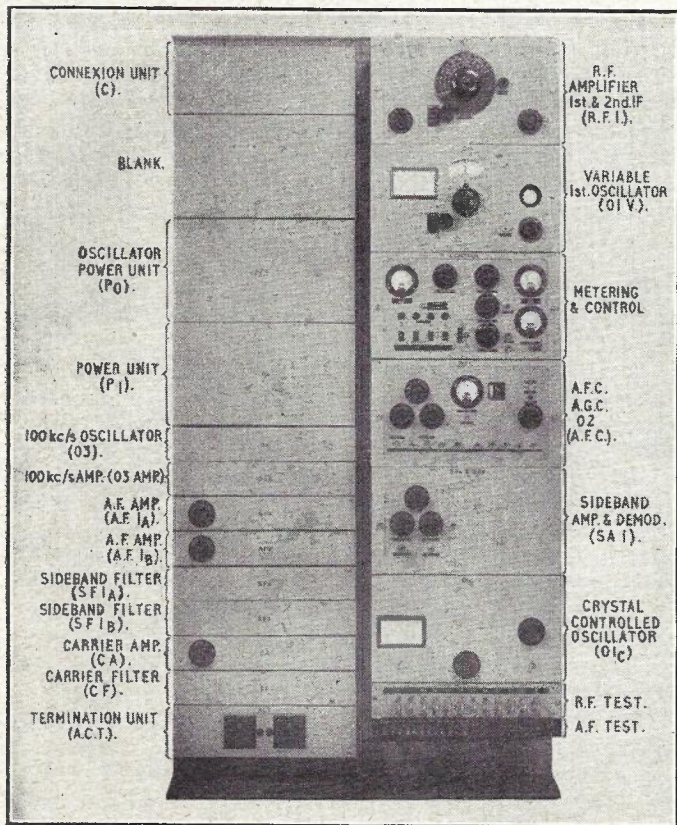

FIG. 2.—THE RECEIVER LAYOUT; SHOWING FRONT TO THE RIGHT AND REAR TO THE LEFT.

two adjacent 6 ft. 5 in. standard racks; normally it is constructed on front and back of one rack. The controls most frequently requiring adjustment are placed at a convenient height on the front of the rack. The apparatus is assembled in units, interconnection of r.f. and i.f. circuits being made by coaxial cable. The units on the front of the rack, other than the metering and control unit, are built on withdrawable chassis, connections being detachable through the use of plugs and sockets. The construction of a typical unit can be seen in Fig. 3, which shows the unit containing the r.f. amplifier.

The anode currents of individual valves can be selected for metering by the operation of switches on the main units, together with a switch on the control unit which selects the unit required.

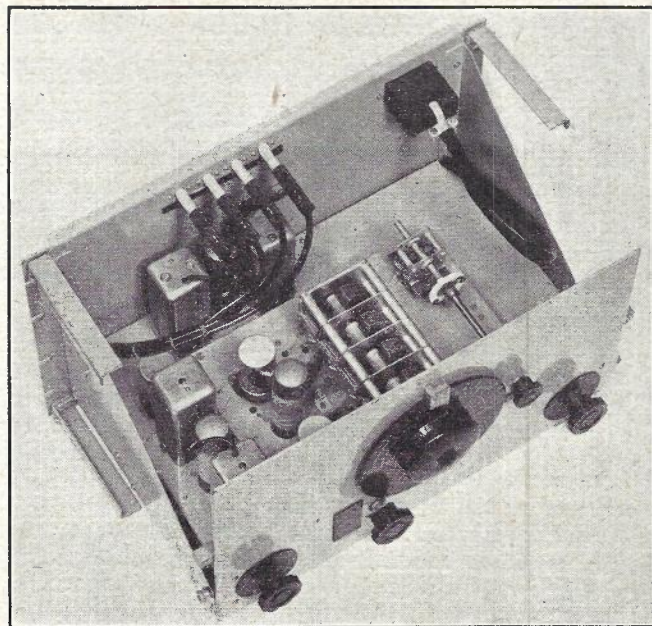

FIG. 3.—CONSTRUCTION OF A TYPICAL UNIT, THE R.F. AMPLIFIER.

DESCRIPTION OF RECEIVER

Radio-Frequency Amplifier.

The radio-frequency amplifier comprises two stages; the first stage uses a short-grid-base low-noise pentode valve, and the second stage a normal variable-mutual-conductance pentode valve.

The gain of the r.f. amplifier is not more than is necessary to ensure that the noise produced by the first frequency-changer is adequately exceeded by that arising in the input circuit and the first valve. To employ more gain than is necessary for this purpose would render the receiver unnecessarily liable to cross-modulation and blocking by strong unwanted signals, or to interference from intermodulation products such as may arise, for instance, from pairs of strong signals spaced by the first intermediate frequency. Blocking refers to changes in level of the wanted signal, produced by strong unwanted signals as a result of overloading in the amplifier or frequency-changer stages. The selectivity provided enables an image ratio of at least 80 db. to be obtained at all signal frequencies.

On the lower frequency ranges the grids of the r.f. amplifier valves are connected to tapplings on the tuning inductors, thus keeping the gain of the amplifier nearly the same on all ranges. The r.f. amplifier is preceded by a rejector circuit for the first intermediate frequency, and an i.f. response ratio of at least 110 db. is obtained.

Frequency-Changers.

The familiar hexode valve has not been used as the first or second frequency-changer because the high level of noise produced by it would have necessitated greater r.f. amplification than is desirable; furthermore, the signal-to-noise ratio would have been degraded when the gain of the r.f. amplifier was reduced by the action of the a.g.c. Instead, a low-noise r.f. pentode has been used in both positions as an anode-bend mixer, with cathode injection from the oscillator.

First Intermediate-Frequency Amplifier.

The first i.f. amplifier should have an image ratio (referred to the second frequency-changer) of at least 80 db., but should have little variation of gain over the band of frequencies occupied by the two sidebands of the transmission. The carrier frequency at the first intermediate

frequency may vary over the range to be corrected by the a.f.c. and over a further range of frequency if a fine tuning control is provided on the second oscillator. In this receiver, the band of frequency over which the amplifier gain should be uniform is 28 kc/s, allowing ± 6 kc/s for sidebands, ± 4 kc/s for a.f.c. and ± 4 kc/s for fine tuning.

The gain in the amplifier is not more than is necessary to prevent the noise arising in the second frequency-changer from setting too low a limit to the signal-to-noise ratio obtained with strong signals. If the amplifier gain is excessive there will be a risk of cross-modulation and blocking from strong transmissions on adjacent frequencies, because the selectivity against such transmissions is necessarily limited. A single stage is used, employing a variable-mutual-conductance pentode with i.f. transformers at grid and anode.

Second Intermediate-Frequency Amplifier.

The signal at the output of the second frequency-changer consists of a 100 kc/s carrier and 6 kc/s wide sidebands; this signal is amplified by a single stage, the anode transformer of which provides an output of 75 ohms impedance. The output of the amplifier is distributed to the carrier and sideband filters by hybrid transformers to prevent interaction between the filters. This stage employs a valve of relatively large signal-handling capacity, as it might otherwise be overloaded by interfering signals which are later attenuated by the filters.

Sideband Filters.

It is necessary for a sideband filter to have a very steep attenuation/frequency characteristic in the neighbourhood of the carrier frequency, in order to discriminate against the other sideband in an independent-sideband transmission, or against adjacent channel noise and interference in a single-sideband transmission. The attenuation in the wanted sideband should be nearly constant from 6 kc/s to within 100 c/s of the carrier, but rise to 45 db. or more (relative to that in the pass-band) for a frequency 200 c/s from the carrier, in the unwanted sideband. The attenuation should be at least 60 db. for frequencies 350 c/s or more away from the carrier frequency in the unwanted sideband.

For frequencies more than 6 kc/s from the carrier and on the same side as the wanted sideband, the overall attenuation should increase by at least 10 db. per kc/s in order to adequately attenuate transmissions on adjacent frequency allocations. This attenuation need not be provided solely in the sideband filter, as the circuit of the sideband amplifier preceding the demodulator is designed to provide part of the required selectivity. The design, construction and performance of the sideband filters is described elsewhere.³

Sideband Amplifier.

The sideband amplifier incorporates two stages of amplification with an adjustable attenuator for correcting sideband/carrier amplitude ratios when necessary. Forward-acting a.g.c. is provided in the sideband amplifier to correct small changes in signal level remaining after the main backward-acting a.g.c. has corrected the larger level changes. Two such amplifiers with demodulators and single-stage a.f. amplifiers are accommodated in the same unit.

Demodulator.

The signal applied to the demodulator from the sideband amplifier consists of one sideband with a low-level pilot carrier, which is attenuated below its normal level by the sideband filter. The main carrier feed (100 kc/s) to the demodulator is supplied either as a reconditioned carrier or from a quartz-crystal-controlled local oscillator. The demodulator is of a linear and balanced type, using diode

valves, and is operated with a carrier level approximately 10 times the peak sideband level. The high ratio of carrier to sideband level enables distortion of the a.f. signal to be reduced to a low level, whilst the balance of the demodulator prevents unwanted amplitude modulation on the carrier (due to noise or interfering signals) from producing an audio output. Furthermore, the wanted signal a.f. output is independent of carrier level over a considerable range; thus, if the pilot carrier applied to the limiter falls below the threshold of limiting during fading, there is little effect on the a.f. output other than a slight increase in distortion. Since the a.f.c. system synchronises the pilot carrier with the 100 kc/s local oscillator, the latter can be used to demodulate the sideband signal without frequency error; the carrier from the local oscillator has the additional advantage of being free from noise. However, provision has been made for the use of the reconditioned carrier if need arises, since it is sometimes of value in preventing a.f. errors, due to small fluctuations of the received signal frequency, which are too rapid for correction by the a.f.c.

The sideband level at the demodulator is determined by the gain of the carrier amplifier as well as that of the sideband amplifier; this arises because an increase in gain of the carrier amplifier results in an increased a.g.c. voltage and a reduced signal level at the input to the sideband amplifier. Provision is therefore made for the adjustment of the gain of the carrier amplifier to a suitable value.

A.F. Amplifier.

Each demodulator is followed by a single-stage amplifier providing a normal output on speech or line-up tone of about 1 mW in 600 ohms. If a higher level is to be sent to line, a two-stage amplifier with adjustable attenuator is provided.

Carrier Filter.

The bandwidth of the carrier filter is a compromise between the small bandwidth desirable to exclude noise and other signals (including the sidebands of the wanted signal) from the carrier amplifier, and the larger bandwidth required to make tuning easy and to prevent the loss of a.f.c. should there be sudden changes in the frequency of any oscillator.

Tests have shown that with an electro-mechanical a.f.c. system capable of dealing with a carrier displacement of ± 50 c/s the bandwidth of the carrier filter 20 db. below the maximum response should be between 100 and 150 c/s. The attenuation of the filter at sideband frequencies should be such that, even with selective fading of, say, 20 db., (a) the carrier level should exceed the sideband level at the limiter used for the reconditioned carrier supply, and (b) the ratio of carrier to sideband level after filtering should be sufficient to prevent the crosstalk attenuation between sidebands from falling below 30 db. when using the reconditioned carrier supply. Ideally the attenuation should rise to a large value for frequencies more than 100 c/s from the mid-band frequency, but the limitations of carrier filter design set a limit to the attenuation which can be economically provided. An attenuation of more than 60 db. relative to that at the carrier frequency, for frequencies more than 250 c/s from the carrier enables both requirements to be met, but sets a limit to the highest levels of sideband components which can be permitted at frequencies less than 250 c/s from the carrier. The equivalent bandwidth for transmission of noise is about 70 c/s, and is 0.01 of that of the sideband channel of 6 kc/s, i.e. the noise power in the carrier path is lower by 20 db. than that in the sideband path. The carrier-to-noise power ratio is thus only 6 db. worse than the peak sideband-to-noise power ratio in the sideband path when the peak sideband-to-carrier ratio is 26 db.

The design, construction and performance of the carrier filter are described elsewhere.³

Carrier Amplifier.

The carrier amplifier is preceded by an attenuator by which the sensitivity can be varied to suit independent or single-sideband transmissions with 26 or 16 db. peak sideband-to-carrier ratios, or double-sideband transmissions. The carrier amplifier is a two-stage linear amplifier which raises the carrier level to a value sufficient for operating the automatic gain-control.

Automatic Gain-Control.

Fig. 1 shows backward-acting a.g.c. applied to all the amplifier stages preceding the second i.f. amplifier. An increase in signal level of 80 db. above the threshold at which the gain-control commences to operate produces a gain-control bias of about 10V, necessary to reduce the sensitivity by about 80 db. However, although the a.g.c. rectifier is provided with a fixed bias of 10V in order to improve the a.g.c. characteristics, an increase of signal level of 80 db. must result in a 6 db. increase of carrier level after the gain-controlled stages. The corresponding increase in the level of the sidebands at the demodulators is minimised by the use of a small amount of forward-acting a.g.c. on the sideband amplifier, as already mentioned.

The most effective time-constants for the charge and discharge of the automatic gain-control system are determined by the nature of the fading. If the fading were normally general-level fading which affected the carrier and sidebands simultaneously to the same extent, small charge and discharge time-constants (e.g. less than 1 sec.) would be preferable, to enable the change of receiver gain to follow the change of signal level quickly. However, the fading of the short-wave signals is selective most of the time, i.e. the fading affects different parts of the transmitted spectrum at different times. Hence, if the a.g.c. is operated from the pilot carrier alone as is usual in s.s.b. operation, it is necessary to use a relatively large discharge time-constant to prevent an increase of a.f. output from occurring as a result of a carrier fade. A discharge time-constant of approximately 50 sec. enables sustained changes of signal level to be corrected, but prevents the gain from changing appreciably during the period of typical selective fades. The optimum value of the discharge time-constant depends on the strength of the signal being received as well as on the period of the fading. This is because the rate at which the gain of the receiver will rise, when the level of the carrier falls below that for which the a.g.c. rectifier is conducting, is proportional to the voltage to which the smoothing capacitor is charged. A smaller value of charge time-constant is preferred to prevent overloading of the receiver when the signal level is rising rapidly; a value of 2 sec. is used in this receiver.

Although the a.g.c. system can be made very effective in correcting relatively slow changes in the average received signal level over a range of some 80 db. or more, it may be desirable to use additional means for correcting the more rapid changes of level due to propagation conditions, but which do not normally exceed some 15 db. For this purpose a constant-volume a.f. amplifier⁴ is frequently employed.

Automatic Frequency Control.

The primary function of the a.f.c. is to maintain the pilot carrier in the narrow-band carrier filter, irrespective of drifts of the incoming carrier frequency or of the frequency of the receiver oscillators. As a secondary function it may be required to synchronise the i.f. carrier with that of the 100 kc/s local oscillator.

The a.f.c. is of the electro-mechanical type employing a motor-driven capacitor to adjust the frequency of the

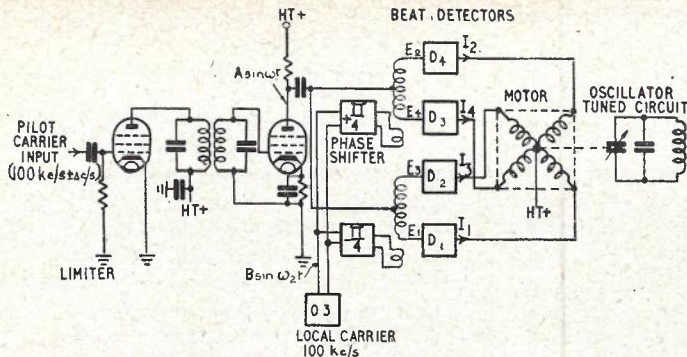

FIG. 4.—ELECTRO-MECHANICAL AUTOMATIC FREQUENCY CONTROL SYSTEM.

second frequency-changer oscillator. Fig. 4 shows that by the use of four anode-bend detector valves supplied from a local oscillator at relative phase shifts of 0°, 90°, 180° and 270°, a four-phase supply at the difference or beat frequency Δ c/s is obtained. As the frequency of the pilot carrier is varied through that of the local oscillator, the beat frequency at the output of the detectors passes through zero and the order of the phases is reversed.

The four-phase current from the detectors is applied to the four stator windings of a variable-reluctance motor, shown in Fig. 5. The speed of this motor is proportional to

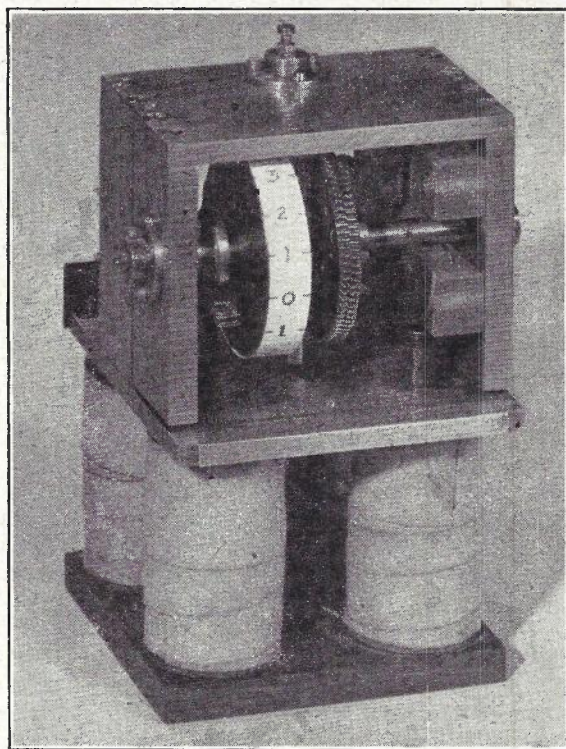

FIG. 5.—VARIABLE-RELUCTANCE MOTOR USED IN AUTOMATIC FREQUENCY CONTROL.

the frequency, Δ c/s, of the applied current. If the pilot carrier frequency is varied through that of the local oscillator, the motor speed falls to zero and the direction of rotation then reverses. The motor is geared to a small variable capacitor connected across the tuned circuit of the second frequency-changer oscillator, and made to drive it in such a sense that the difference in frequency between the pilot carrier and the local oscillator is reduced, the motor continuing to run until the frequency difference, Δ c/s, is zero.

The electromechanical form of a.f.c. differs from the electronic (reactor valve) system in that there is no residual

error-frequency and no tendency of the a.f.c. to drift, should the pilot carrier be interrupted; local carrier can, therefore, be used for demodulation normally without any frequency error.

The relative phase of the pilot and local carriers is shown by a small oscilloscope mounted on the variable first oscillator unit; the spot traverses a circle rapidly when the motor is first synchronising the oscillators, but then moves slowly as the a.f.c. corrects any drift.

Crystal-controlled First Oscillator.

The crystal-controlled first oscillator provides a choice of nine pre-set frequencies in the ranges 7.1 to 13.1 Mc/s and 6.9 to 26.9 Mc/s; these frequencies are required for frequency-changing signals in the ranges 4 to 10 Mc/s and 10 to 30 Mc/s. A nine-position switch mounted on the oscillator unit selects the crystal, the pre-set amplifier or doubler circuits and the level control appropriate to the desired frequency. Each set of pre-set circuits is adjustable over a frequency range of about 1:1.5, the ranges covering 6 to 15 Mc/s being duplicated because they correspond to two ranges of signal frequency.

Variable-Frequency First Oscillator.

Good short-term stability of oscillator frequency is essential in s.s.b. or i.s.b. receivers because, although a slow drift of several kilocycles per sec. can be corrected, a sudden jump of 50 c/s or more can render the a.f.c. ineffective by removing the pilot carrier from the narrow bandwidth carrier filter. Mechanical stability is required both in the sense of freedom from vibration and as regards uniformity of expansion and contraction of the oscillator circuit elements with changes of temperature.

In this receiver the oscillator sub-chassis is isolated from the main chassis by shock-absorbing mountings, and the inductor is of simple, robust construction. The inductor is self-supporting and is mechanically damped with strips of polythene; the connection to the variable capacitor is made by a glass-to-metal seal. The valve electrodes are tapped across part of the inductor in order to minimise changes of frequency due to changes of valve capacitances. Frequency-range changing is achieved by frequency doubling in a later stage, thereby avoiding instability due to switching in the oscillator circuit. The use of a specially designed tuning drive with spring-loaded split gears avoids backlash and enables the tuning to be accurately reset.

The effect of the valve on the frequency of oscillation is so small that stabilisation of the mains supply voltage to the H.T. supply unit feeding the oscillator is usually unnecessary. The heater supply is rectified and smoothed to avoid frequency modulation at the mains frequency.

PERFORMANCE CHARACTERISTICS

Sensitivity and Signal-to-Noise Ratio.

In the absence of radio noise the peak sideband voltage, which is necessary to produce a 25 db. signal-to-noise ratio with a 6 kc/s band, is approximately +7 db. relative to 1 μ V in series with a 75-ohm source to which the receiver is matched. With suitable design it is possible to approach this theoretical limit within a few decibels, as is shown by the measured characteristic in Fig. 6.

The a.f.c. system operates effectively even though the signal-to-noise ratio in the sideband path is barely sufficient for an order-wire circuit.

When the signal-to-noise ratio in the sideband path is 15 db., the pilot carrier in an independent sideband system

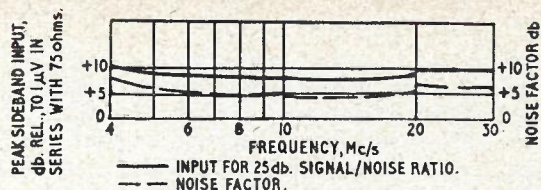

FIG. 6.—INPUT FOR 25 DB. SIGNAL/NOISE RATIO AND NOISE FACTOR.

would have a level of approximately -26 db. relative to 1 μ V, which may be regarded as a suitable threshold level for the carrier. If the carrier fades below this level the a.f.c. remains at the last corrected value until the carrier level rises again to the threshold value.

Selectivity.

The overall selectivity is determined mainly by the sideband filters and the sideband amplifiers; Fig. 7 shows the

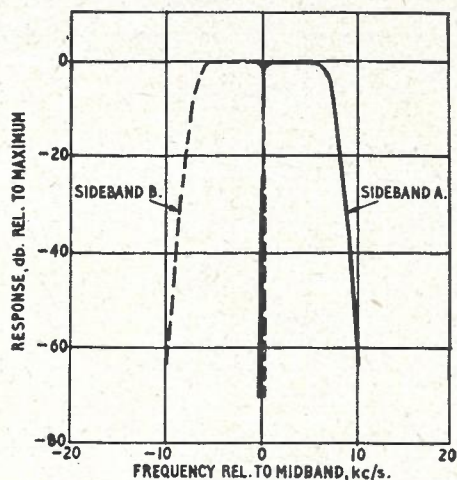

FIG. 7.—OVERALL SELECTIVITY CHARACTERISTIC (UP TO DEMODULATOR INPUT).

measured overall selectivity characteristic of the receiving equipment from the aerial input to the demodulator input. The contribution of the sideband filters to the selectivity is shown by Fig. 8, which also includes the response of the

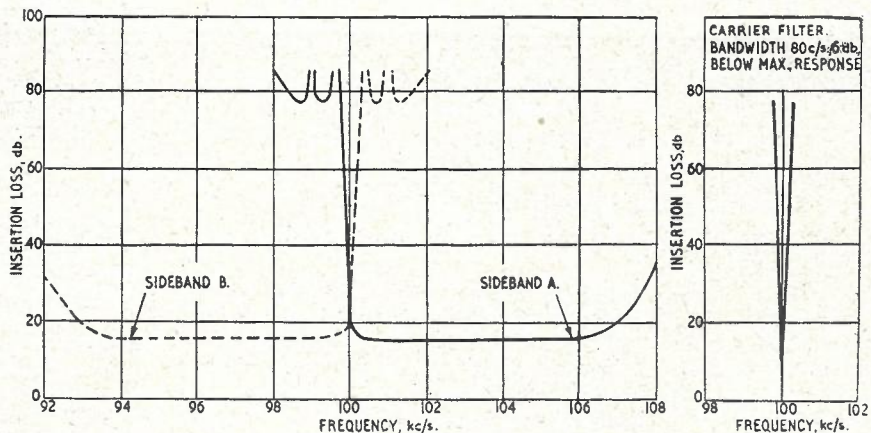

FIG. 8.—CHARACTERISTICS OF SIDEBAND AND CARRIER FILTERS.

narrow-band carrier filter.

Interference from other speech-modulated transmissions takes the form of unintelligible sideband splash owing to the sharp selectivity provided and the use of a high-level carrier in the demodulator, and is due to those components of the unwanted signal that fall within the pass-band of the receiver, all other components being effectively excluded.

Automatic Gain-Control.

By the use of a forward-acting a.g.c. on the sideband amplifier in addition to the normal backward-acting control on the r.f. and first i.f. stages of the receiver, the a.f. output for a given sideband-to-carrier ratio varies by less than 3 db. when the peak sideband input is increased from +10 to +100 db. relative to $1 \mu\text{V}$, as shown in Fig. 9.

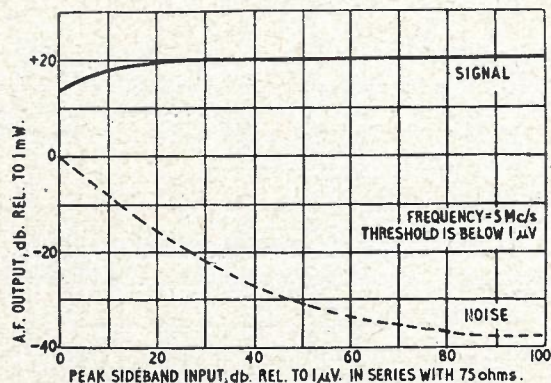

FIG. 9.—AUTOMATIC GAIN CONTROL CHARACTERISTIC.

As the input signal level is increased the gain of the receiver is reduced and the noise output decreases nearly proportionately, up to a limit set by the noise from the non-gain-controlled stages, as shown by the dotted curve.

Overall Frequency/Response Characteristic.

The overall audio-frequency/response characteristic between 200 c/s and 6 kc/s is determined mainly by the attenuation characteristic of the sideband filter, since the r.f. and first i.f. circuits are designed to have a negligible variation of response over the range of frequencies which may be occupied by the transmission. An overall response uniform to within about 2 db. from 100 c/s to 6 kc/s is obtainable, as shown in Fig. 10.

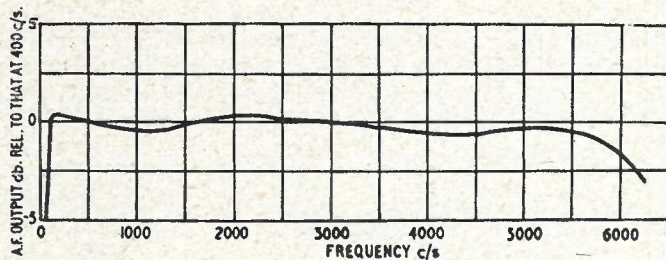

FIG. 10.—SIDE BAND FREQUENCY/A.F. RESPONSE.

Cross-Modulation and Blocking Characteristics.

The cross-modulation and blocking characteristics are shown in Fig. 11.

In the cross-modulation test, the unwanted carrier is ± 10 kc/s from the pilot carrier of the wanted signal, and is modulated 30 per cent. at 400 c/s. The cross-modulation produces unwanted components 400 c/s above and below the frequency of the wanted tone. The level of the unwanted carrier required to produce 400 c/s cross-modulation 20 db. below the level of a single-frequency wanted sideband signal is determined for various levels of the latter. The good performance shown in Fig. 11 is the result of careful distribution of the gain and selectivity in the receiver. The gain distribution of the stages preceding the filters is shown in Fig. 12.

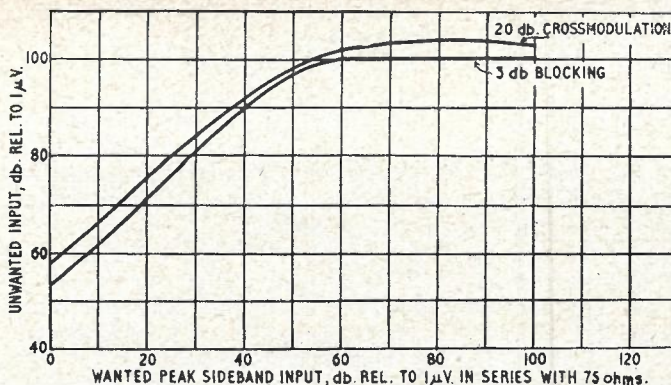

FIG. 11.—BLOCKING AND CROSS-MODULATION CHARACTERISTICS AT 4 Mc/s.

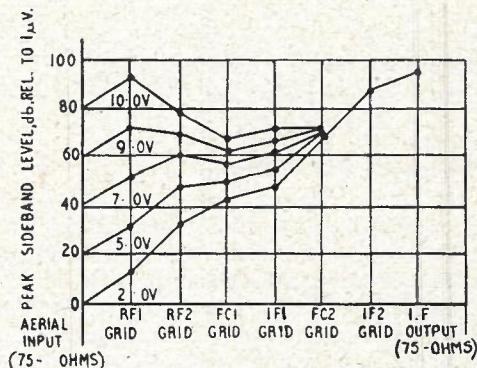

FIG. 12.—LEVEL DIAGRAM (VOLTAGES SHOWN AGAINST CURVES ARE A.G.C. VOLTAGES).

Non-Linear Distortion.

Third-order intermodulation products of the type $2f_1 - f_2$, that might cause cross-talk from one sideband into the other, do not exceed a level of -50 db. relative to either of the two sideband signals of frequencies f_1 and f_2 for all levels of the peak sideband, up to +80 db. relative to $1 \mu\text{V}$.

CONCLUSIONS

The receiver described closely approaches the limits of performance theoretically obtainable in respect of sensitivity, faithful reproduction of the intelligence conveyed by the signal and freedom from avoidable interference. The satisfactory nature of the design has been confirmed by extensive tests at one of the Department's short-wave radio receiving stations. A considerable number of receivers of this type are now in production.

ACKNOWLEDGMENT

The authors wish to acknowledge the part played by Mr. W. J. Bray in the initial planning of the receiver and the assistance of the Radio Maintenance Branch in the tests at a radio station.

References.

- 1 W. J. Bray and D. W. Morris. "Single-Sideband Multi-Channel Operation of Short-Wave Point-to-Point Radio Links; Part 1, General Survey," *P.O.E.E.J.*, Vol. 45, p. 97.
- 2 F. C. Owen and A. B. Ewen. *Ibid.*, Part 2, "A Two-Channel Transmitter Drive Unit and Monitor Receiver," *P.O.E.E.J.*, Vol. 45, p. 154.
- 3 C. F. Floyd and R. L. Corke. "Crystal Filters for Radio Receivers," *Journal I.E.E.*, 1947, Vol. 94, Part IIIA, No. 16, p. 915.
- 4 L. T. Arman and P. R. Hutton-Penman. "The Application of a Constant Volume Audio Amplifier to a Short-Wave Single-Sideband Trans-Atlantic Radio Circuit," *P.O.E.E.J.*, 1938, Vol. 31, p. 104.

Telegraph Power Plant using a D.C. Astatic Relay for Voltage Control

R. E. HILL, Graduate I.E.E.†

U.D.C. 621.394.668: 621.316.722.1.077.6

This article gives a description of the 50V rectifier power plants designed for use in the teleprinter automatic switching and phonogram automatic distribution systems. Divided battery float operation is employed and regulation is by means of a voltage sensitive D.C. astatic relay controlling a motor-driven regulator. Much attention has been given to simplicity in design and to securing immunity from the effects of interruptions in mains supply.

Introduction.

POWER supplies at 50V are required for telegraph services for the first time with the introduction of Teleprinter Automatic Switching and Phonogram Automatic Distribution schemes, and can, in some cases, be supplied from an adjacent telephone exchange. Generally, however, this telegraph equipment is installed with the multi-channel voice frequency terminal at a repeater station or with the telegraph instrument room at a Head Post Office, where a 50V supply is rarely available and special provision must be made for the automatic telegraph equipment. Several new floating battery power plant schemes were being developed by the Post Office in the immediate post-war years and one particular scheme of rectifier regulation, by means of a Ferranti D.C. Astatic Voltage Relay, a voltage-sensitive device, controlling a motor-driven Ferranti Moving Coil Voltage Regulator, had reached a satisfactory stage by 1949. The D.C. astatic relay was a result of development, carried out by Ferranti Ltd. and the Post Office, of the A.C. astatic relay which had been in production for a number of years. The use of the latter relay is limited to the control of telecommunications power plants supplying constant loads, e.g. L.T./H.T. power plants.

Experience during the war years had indicated the suitability of rectifier power plants with selenium elements for telegraph power supplies, and it was decided to order several 50V rectifier power plants with voltage control by means of the Ferranti D.C. astatic relay and moving coil regulator, to meet the telegraph automatic switching and, later, the phonogram automatic distribution programmes. The circuit and the operation of these new power plants were kept as simple as possible to give maintenance staffs confidence and to ensure a power supply immune from interruptions. The plants have been manufactured in three sizes with maximum outputs of 60, 100 and 200 amps. and are for divided battery float operation of two 25-cell batteries; the capacity of the batteries is determined by the period of reserve required to cover mains supply failure. The equipment costs, installation charges and expenditure on accommodation compare favourably with the equivalent motor generator plants.

Voltage Control of Floating Batteries.

To appreciate the reasons for the development of the D.C. astatic relay and its adoption in the 50V telegraph power plants it may be useful to review the requirements of a floating battery system. For such a system to function satisfactorily and give long periods of service without frequent boost charging, with the consequent wear and tear of the battery, the floating battery voltage per cell must be as high as possible subject to upper limits imposed by the cells and the equipment supplied; also the response of the voltage-sensitive device and the regulator which it controls must be as rapid as possible with complete stability. For 50V systems supplying automatic switching apparatus the voltage limits of 52V and 46V at the rack bus-bars are determined by the design of this apparatus.

To ensure maximum use, under mains failure conditions, of the stored energy in the battery, without the complication of end-cell switching or inefficient series regulating resistors, and taking into account distribution voltage drop, it is necessary to employ a 25-cell battery. The upper limit of 52V for a 25-cell battery is below the optimum floating voltage for the maintenance of a fully charged condition over long periods; it is desirable, therefore, for the system voltage to be regulated as close as possible to, but not exceeding, this upper limit. If the limits of control on such an installation are ± 2 per cent. then the mean point of regulation can be set no higher than 51V, otherwise the voltage limits at the automatic switching apparatus may be exceeded. Due to the slow response of the battery voltage, these wide limits may permit a lengthy period to elapse, following an increase in load, before the regulator comes into operation. During this time the floating battery may lose considerable capacity. On the other hand, if the regulation can be maintained as close as ± 0.5 per cent. then the mean point of regulation may be set as high as 51.75V. With the latter condition there will be less local action in the cells and less discharge to meet load increases, and consequent loss of capacity, than in the former condition. If the regulating devices are slow in operation, or their limits of control wide, there will be a greater tendency for the voltage to be off limits whilst load changes are being corrected than if the regulator is rapid in response. Furthermore, with slow correction the battery will lose more of its stored energy when the load on the installation increases than it can pick up when the load decreases, unless the load changes are also slow, and this is not necessarily the case under working conditions.

A voltage control within fine limits, that is a sensitive controlling device, and a rapid response regulator are not complementary factors. Voltage-sensitive devices for the type of plant under consideration which were available before the development of the D.C. astatic relay resulted in hunting if adjusted for fine limits to control the operation of rapid response regulators. This was due in part to the time of response of the control circuit. Hunting causes unnecessary wear on the moving parts of a system and also widens the limits of regulation, defeating the object of the sensitive adjustment. The ideal scheme required is that in which the complete control and regulating circuit responds very rapidly to the slightest change in voltage across the floating battery brought about by load changes, as this enables the rectifier output to be adjusted to follow the load automatically and no current then flows into or out of the battery. The D.C. astatic relay with its associated circuit when used in conjunction with a fast regulator approaches this ideal.

THE D.C. ASTATIC RELAY

The Mechanism and its Operation.

The D.C. astatic relay consists of an iron core or plunger which is free to move up and down the vertical axis of a coil connected to the points across which constant voltage is desired. The plunger is linked to a pendulum movement on which is mounted a mercury switch with a simple change-

† Assistant Engineer, Telegraph Branch, E.-in-C.'s Office.

over action. Movement of the plunger effects the operation of the switch as shown diagrammatically in Fig. 1. The design of the relay is such that the pull on the plunger, for a

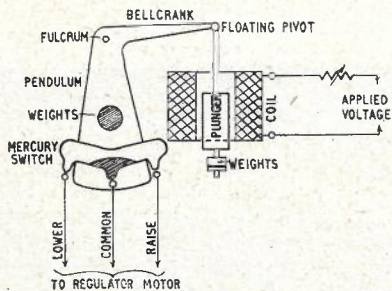

FIG. 1.—EXPLANATORY DRAWING OF D.C. ASTATIC RELAY MECHANISM.

given applied voltage, is virtually independent of the plunger position over a wide range of movement. If, therefore, the voltage applied to the relay coil is adjusted so that the electromagnetic force on the plunger is equal and opposite to the weight of the plunger assembly, then the plunger will be astatic, i.e. it will not tend to take up any fixed position. The forces acting on the mercury switch are arranged so that it is balanced in a neutral position at the voltage of control required. With changes of the applied voltage the plunger will take up different balance positions at which the change in the magnetic force on the plunger is balanced by the pendulum action of the switch assembly. If the change exceeds the sensitivity setting of the relay the switch will complete the regulator motor drive circuit in the appropriate direction for the necessary correction. The desired voltage and sensitivity settings are obtained by adjustment of the pull on the plunger and of the pendulum effect; the former by the combination of the coil circuit resistance and the weight attached to the plunger, and the latter by the weights on the switch movement.

The travel of the moving parts of the relay on the boost side is sufficient to allow for the mercury stream in the switch to be broken under excessively low voltage or no voltage conditions (such as would occur due to a fault in the coil circuit) with the result that the motor circuit of the regulator remains unenergised until the fault is cleared.

This method of low voltage protection is shown in Fig. 2.

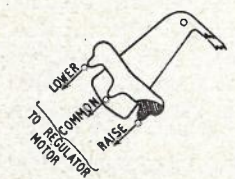

FIG. 2.—NO-VOLT PROTECTION.

To compensate for ambient temperature changes an additional mechanism, effective within the range 10°C to 40°C and changing at not more than 5°C per hour, is linked to the pendulum. This compensating arrangement is a bimetal spiral spring, which expands or contracts with temperature changes, attached to the pendulum fulcrum at its inner end and with a weight attached to the free end. The movement of the weight balances the change in pull on the plunger due to resistance changes in the relay coil. The compensating mechanism is housed in a lagged compartment. The D.C. relay and associated current transformers, described later, are mounted in a totally enclosed case for flush mounting on the face of the power plant, and the relay is operated with the cover in position so that the temperature will only change slowly.

The Electrical Circuit.

The basic circuit showing the connections of the D.C. relay is given in Fig. 3. The voltage at which the relay balances is determined by the setting of the rheostat YF. A special compounding circuit is associated with the relay

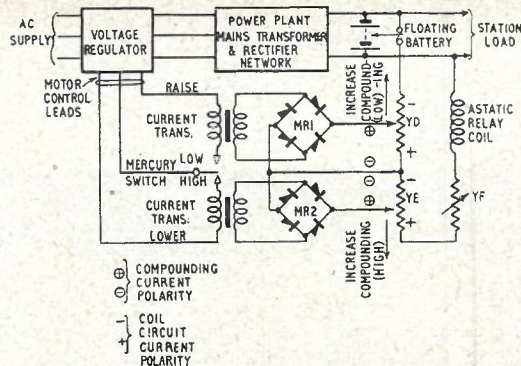

FIG. 3.—CIRCUIT OF D.C. ASTATIC RELAY.

to overcome surface tension effects of the mercury on the electrodes of the switch, resulting normally in a fairly long minimum make period, and to overcome the inertia of the switch, to prevent hunting of the relay when controlling high-speed regulators in the input to the power plant and to facilitate voltage control within close limits. The regulator motor derives its operating current from a single phase of the input supply to the power plant, and the operating circuit of the motor is completed via the primaries of the current transformers as shown. When the mercury switch makes contact because of a variation of the voltage across the floating battery, a current will flow through the rectifier network and its load from the secondary of the current transformer, the primary of which is in the regulator motor drive. The rectified current will flow through one of the compounding resistors (YD or YE depending on the direction of drive) in the relay coil circuit and its effect will be to oppose the current change in the relay coil which caused the original movement of the mercury switch, i.e. to restore the correct balance voltage across the coil terminals giving the impression that correction has taken place.

Regulation Features.

When the voltage across the floating battery falls below the limit determined by the sensitivity setting, the mercury switch makes on the "low" side and completes the drive circuit of the regulator motor in the "increase volts" direction. The compounding current from the rectifier network MR1 will flow in the resistor YD and produce a potential difference which adds to the battery E.M.F. across the relay coil circuit. If this potential difference is appreciably larger than any further decrease in the battery E.M.F., the current through the relay coil will increase and the plunger of the relay, and hence the mercury switch, will tend to restore to its original position of balance.

When the voltage across the floating battery rises above the limit determined by the sensitivity setting, the mercury switch makes on the "high" side and completes the regulator motor drive circuit in the "decrease volts" direction. The compounding current from the rectifier network MR2 will flow in the resistor YE and produce a potential difference which is in opposition to the battery E.M.F. across the relay coil circuit. If this opposing potential difference is appreciably greater than any further increase in the battery E.M.F., the current through the relay coil will decrease and the plunger of the relay, and hence the mercury switch, will tend to restore to its original position of balance.

The magnitude of the compounding effect is determined by the setting of the variable compounding resistors YD and YE: with a maximum value of resistance across the rectifier network the compounding and therefore the "pull off" feature will be a maximum. The effect of maximum compounding in practice is for the regulator to be "inched"

slowly to the desired position for voltage correction. Such a slow correction may allow the system voltage to vary from the permitted limits. On the other hand, if there is no compounding a high-speed regulator will over-run owing to the minimum make period, and if the sensitivity setting of the relay is close, hunting will result. The ideal setting of the compounding resistors is dependent upon the normal rate of change of the load, the capacity of the floated battery and the regulator speed. It will be appreciated that by a suitable selection of the sensitivity and the compounding effect (inching of the regulator) the control circuit can follow the load changes on the installation with very little change in the state of the floated battery. The change in the coil circuit current, brought about by maximum compounding, is of the order of one part in a thousand in either direction and, in the 50V telegraph plants so far installed, a setting of one-third on both compounding resistors has been found to give satisfactory regulation of ± 0.5 per cent. at divided battery float voltages. Regulation as good as ± 0.25 per cent., without any tendency for hunting, was obtained on the same plants with greater amounts of compounding and a more sensitive setting of the relay. The true nature of the telegraph automatic switching loads cannot yet be assessed and it is not proposed to adopt the close limits of regulation of ± 0.25 per cent. until more information on load conditions is available. Table 1 details the regulation limits obtained without hunting from an experimental D.C. astatic relay and power plant working under various conditions. Experience with the manufactured

Facilities.

The power plants provide the following facilities:—

1. A smoothed voltage-controlled supply for floating a 25-cell battery and supplying a station load from one of the two rectifier cubicles provided.
2. A manually controlled charge, by means of push-button operation, of a second 25-cell battery from the second rectifier cubicle.
3. Main switching to enable:—
 - (a) either rectifier cubicle to be associated with either battery for float or charging conditions.
 - (b) Manual paralleling of the batteries under mains failure conditions so that the maximum reserve capacity may be available because of the lower rate of discharge.
4. Subsidiary switching to enable the automatic voltage control circuit to be associated with one of the rectifier cubicles and the manual push-button control to be associated with the other rectifier cubicle, or vice versa.
5. A visual and extended alarm under any of the following conditions.
 - (a) Phase fail.
 - (b) Mains fail.
 - (c) Fuse fail.
 - (d) Contactor fail.
6. Automatic disconnection of the rectifier cubicles from the batteries in the event of a mains supply failure, and automatic reconnection without attention when the mains supply is restored.
7. Automatic current limiting and over-load protection when floating or charging. This facility also provides automatically assisted discharge if required.
8. Measurement of currents and voltages at various parts of the circuit.

TABLE 1

Regulation Limits of the D.C. Astatic Relay obtained on an Experimental Plant

Conditions	Voltage Limits	Setting of both Compounding resistors
Single Battery Float (2·16V/Cell)	± 0.5 per cent.	Full
	± 0.8 per cent.	$\frac{2}{3}$ full
	± 1.2 per cent.	$\frac{1}{3}$ full
Divided Battery Float (2·06V/Cell)	± 0.5 per cent.	$\frac{2}{3}$ full
	± 0.8 per cent.	$\frac{1}{3}$ full
	± 1.2 per cent.	Nil
No Battery, i.e. rectifier plant supplying load direct	± 0.5 per cent.	Full
	± 1 per cent.	$\frac{1}{3}$ full
	± 1.2 per cent.	$\frac{2}{10}$ full

power plants indicates that the results apply equally to production models of the relay.

The D.C. astatic relay is suitable for automatic control of telecommunications power plant regulators because it is robust and all bearing surfaces are hard chromed and mostly knife edges. Also there are no springs controlling the operation of the switch, thus eliminating troubles due to spring creepage affecting the calibration. Further, since the switch is of the mercury boat type, the chattering and burning of the contacts is overcome by the meniscus action of the mercury. The rating of the switch is 10 amps., and on the larger regulators which require a high driving torque derived from several motors the complication and consequent delay caused by auxiliary relays is avoided.

The Circuit.

The basic diagram of the power plants is given in Fig. 4. With the object of clarity, most alarm and metering circuits, and the second cubicle, have been omitted.

The current relay M breaks its lower contact at 95 per cent., and makes its upper contact at 105 per cent., of the full-load output of the cubicle. The short-circuit applied by CRB across the "lower volts" drive circuit ensures that the

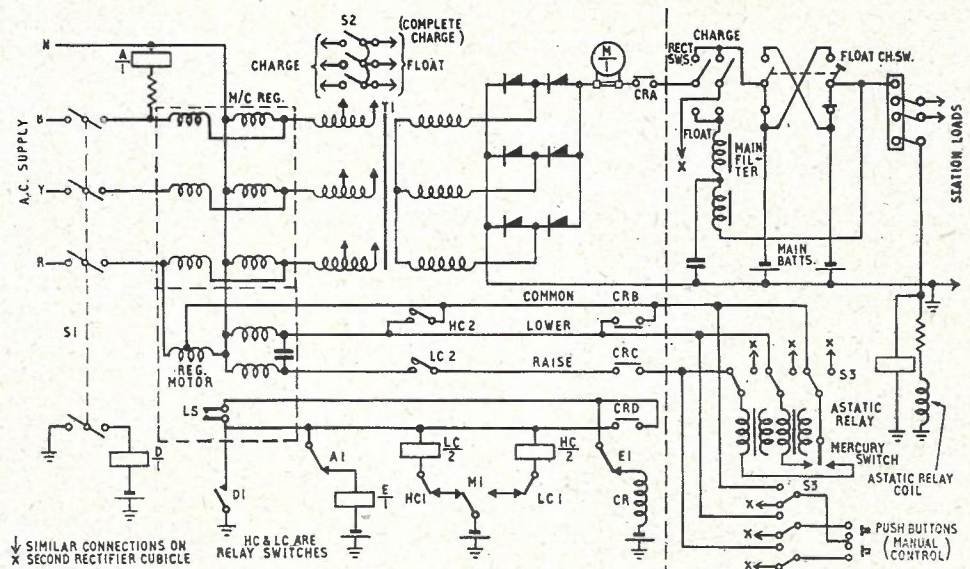

FIG. 4.—SIMPLIFIED CIRCUIT OF 50V POWER PLANT.

regulator is driven to its position of minimum volts, when the cubicle is switched on by S1, before the main contactor CR, operated by the limit switch LS, connects the rectifier to the battery. CR is held by its own contact CRD via E1 when the output voltage of the regulator is driven up and the limit switch released. S3 determines whether the cubicle shall be on automatic or push-button regulation. The automatic regulation functions, as described above, for voltage regulation up to 95 per cent. full-load output of the cubicle. Above this output the current relay M exercises a control limiting the output to 105 per cent. full-load output independently of the voltage. It will be appreciated that this arrangement lends itself to assisted discharge working, and permits automatic reconnection of the cubicle to the battery after a mains failure. S1 is the on-off switch and S2 increases the turns ratio of T1 and provides a higher voltage output for completion of charge conditions. The Ferranti moving-coil voltage regulator has already been described elsewhere.¹ Its motor is an induction disc type which requires neither overload protection nor automatic brake. The relay across each phase, typified by relay A, performs an alarm function, operating relay E, thus releasing the contactor, in cases of mains or phase failure.

Electrical Characteristics.

The input supply to all three sizes of power plant is three-phase A.C. of any nominal line voltage between 346 and 440V. Additional tappings are provided on the mains transformers to cater for any rectifier element deterioration. The output voltage is maintained, by automatic regulation, within the limits of $\pm 0.25V$ of the floating battery voltage under any load condition from no-load to full-load, with input voltage variations of + 6 per cent. and - 10 per cent. of the declared supply voltage, and frequency variations of ± 5 per cent. of the declared supply frequency, 50 c/s.

Table 2 gives the efficiency and power factor figures for these power plants. In addition there is a small power loss, not exceeding 1 per cent., in the filters.

TABLE 2
Efficiency and Power Factor of the Power Plants

Plant Size	Full Load		Half Full Load	
	P.F.	Efficiency (watt)	P.F.	Efficiency (watt)
60 amp.	0.85	75 per cent.	0.73	79 per cent.
100 amp.	0.87	78 per cent.	0.79	82 per cent.
200 amp.	0.89	80 per cent.	0.84	82 per cent.

Smoothing.

Phonogram equipment requires a supply smoothed to the same degree as telephone equipment, i.e. a psophometric value of 2 mV noise weighted, and so that the power plants may be standard, smoothing equipment designed in accordance with the standard procedure² was provided in the floating circuit. Actual noise measurements taken on a 200-amp. plant were 0.5 mV to 0.6 mV from no-load to full-load and, for a 60-amp. plant, 0.5 mV to 1 mV from no-load to full-load. Tests carried out in the field showed that excessive noise was being induced into the floating battery loop, and hence into the station busbars, from the unsmoothed output of the other rectifier when used for charging the second battery. Analysis showed that the 300-c/s ripple on the output of a rectifier cubicle was 3V. Only slight improvement could be made by rearrangement of the battery layout and cabling and the cubicle busbars, so

it was decided to make provision for simple filters, to be included in the charge circuit, based on the results of tests carried out at the power plant manufacturer's works.

Physical Arrangement.

Fig. 5 is a front view of a 200-amp. plant which consists of

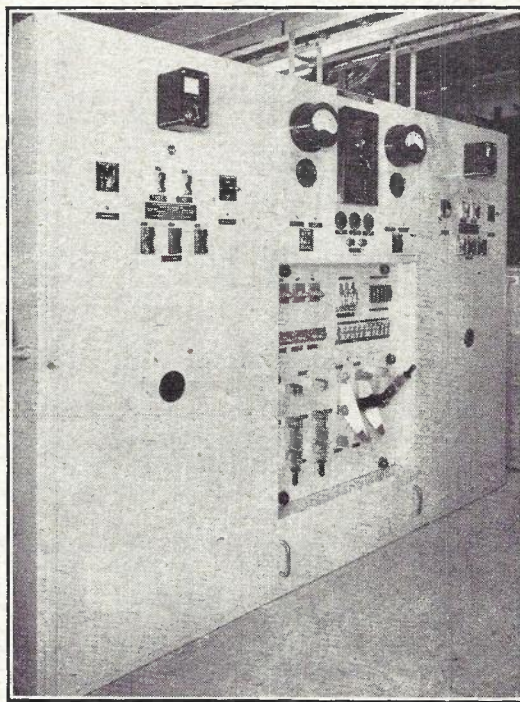

FIG. 5.—A 200-AMP. POWER PLANT, FRONT VIEW.

a centrally situated cubicle for the functions of control, switching, smoothing and distribution, with a rectifier cubicle on either side. Each rectifier cubicle is identical and the rating of each is 200 amp. at 52V. All three cubicles are self supporting, but are bolted together, when installed, so as to form one unit. The rear panels of the rectifier cubicles are expanded metal on frames, and lift-off doors are provided at the back of the central cubicle. A "pull-off" door situated under the main switching panel at the front of the power plant provides access to the filter capacitor fuses. The inter-cubicle connections are by busbar links and pre-fabricated cable forms of the correct dimensions. Not shown in the illustration are two smaller free standing regulator cubicles, one associated with each rectifier cubicle. These regulators are normally mounted in line with the main suite, to which they are linked by short flexible conduits. Where accommodation is restricted, the regulators may be installed in the power room at any reasonable distance from the main cubicles, and the connections completed by longer cables in fixed conduits. Entry at the top of the main cubicles is arranged for the incoming A.C. supply conduits and the battery and distribution cables, thus eliminating the expense of floor chases. Should floor chases be available, or necessary, at an installation, then the incoming connections may be brought in at the base of the cubicles as these are of open construction. Standard Post Office components have been used as far as possible for the construction of the power plant, so as to facilitate maintenance replacement in the future. The 100 and 60 amp. sizes of power plant are scaled-down versions of the one illustrated, a height of 6 ft. 6 in. being retained in all cases. The dimensions of the power plants are given in Table 3. It will be appreciated from the foregoing description that the task of installing one of the power plants is not a difficult one.

¹ I.P.O.E.E. Printed Paper No. 188: Power Supplies for Telegraphs.

² I.P.O.E.E. Printed Paper No. 173: Audio-Frequency Ripple from D.C. Power Supplies in Communication Engineering.

TABLE 3
Dimensions of Power Plants

Plant Output	Main Suite of Cubicles			Each Regulator			Overall length of complete plant (see note)
	Length	Depth	Height	Length	Depth	Height	
60 amp.	6' 8"	1' 7"	6' 6"	1' 2"	1' 7"	3' 3"	10'
100 amp.	7' 0"	1' 10"	6' 6"	1' 8"	1' 10"	3' 9"	11' 4"
200 amp.	8' 9"	3'	6' 6"	2' 2"	2' 3"	4'	14' 1"

NOTE.—When a complete power plant is installed in one line, a space of 6" is allowed for ventilation between the regulator cubicle and the adjacent rectifier cubicle.

CONCLUSION

The circuit and specification for the power plant described were prepared by the Post Office, and the physical design and manufacture were carried out by the Westinghouse Brake & Signal Co., Ltd. A number of these power plants of the various sizes have now been installed at telegraph centres. The reaction of the installation and maintenance staffs concerned has been very favourable, and the new equipment is proving to be satisfactory in service.

The use of the D.C. astatic relay has been extended to the control of L.T./H.T. rectifier power plants at present being manufactured for the filament and anode supplies to type III M.C.V.F. equipment. These plants are similar to the 50V plants described and will have outputs of up to 400 amps. at 26V and 40 amps. at 150V for the L.T. and H.T. sections respectively. Each section consists of three rectifier cubicles and a control and distribution cubicle. The rectifier cubicles

are each rated for half the station load and it is proposed to operate two of these cubicles in parallel; the third cubicle is for standby and battery-charging purposes. In these plants a slower speed regulator is used, since the L.T./H.T. loads are fairly constant, and so it should be possible to obtain very close regulation of the floating battery voltages.

It should be stated in conclusion that there have been recent advances in electronic and transducer control of rectifiers. One such scheme has recently been described.³ These advances may well be the beginning of completely static telecommunication power plants for D.C. supplies, if the costs are favourable, since such schemes are much superior to any form of regulation involving finite steps of control, however small these steps may be.

ACKNOWLEDGMENTS

This article would not be complete without a reference to Mr. A. Wilcock, of the Post Office, who was closely associated with Ferranti, Ltd., in the development of the D.C. astatic relay. The author also wishes to acknowledge the advice and help given by his colleagues of the Telegraph Branch in the preparation of this article, and to thank Ferranti, Ltd., for information supplied, and the Westinghouse Brake & Signal Co. and Regional staffs, especially the L.T.R. Power Section, for assistance with tests carried out. The Test and Inspection Branch provided the information given in Table 3.

³ *Electronic Engineering*, Dec. 1952. The Transbooster (Walker)

A Partial Call Queuing Scheme for Sleeve-Control Exchanges

As a further attempt to solve the problem of the "Unfortunate Call" at exchanges equipped with multiple answering jacks, a "Partial Call Queuing Scheme" is being tried out at various representative sleeve-control exchanges. The equipment in its present experimental form caters for 400 multiple answering equipments and provides for 25 incoming calls to be queued in their order of arrival, but only a limited number to be displayed on the switchboard at any one time; this number being controlled by the supervisor between the limits of 3 and 11. To eliminate the "Unfortunate Call" the display of calling signals is dependent on the answering of the first call in the queue. For example, if the maximum number of signals to be displayed is set by the supervisor at six, then incoming calls will be queued and displayed as they arrive until a maximum of six calling signals have appeared on the switchboard. As the arrangement of the multiple answering lamps and jacks is not altered in any way, the signals will appear anywhere in the answering field and they will not necessarily be answered in correct order of arrival. However, the equipment prevents any further calls being displayed until the first call in the queue has been answered. Thus the maximum amount of time a call can be answered "out of turn" is the time taken to answer a batch of displayed calls.

When there are more than 25 calls awaiting answer at any one time, a pool of calls will form outside the queue; these calls will be picked up at random as queue places become vacant. Under these circumstances queuing in strict order of arrival cannot be guaranteed, but with normal traffic such conditions should rarely occur.

The equipment consists of one standard rack of switch-

ing apparatus and a control panel, the latter being fitted in the switchroom. No alterations have been made to existing sleeve-control circuits. The equipment can be brought into use by suitable jumpering changes on the I.D.F. The existing lamp wire between the incoming relay set and the lamp relay is cut and diverted into and out of the equipment, i.e., one single wire jumper is recovered and two single wire jumpers are run for each multiple answering equipment.

Facilities are provided for quick reversion to normal random answering in the event of failure of the switching system. This is controlled by a key on the control panel which also contains the necessary visual and audible alarms. Other facilities provided on this panel include a lamp display of the number of calls in the queue, 25 keys and lamps by which a "no display" fault in any one of the queue places can be detected and locked out of service, a switch for altering the number of calls which can be displayed, etc.

Apart from the basic function of eliminating the "Unfortunate Call" the fact that all incoming calls pass through the equipment has made it possible to record automatically on meters various useful traffic statistics such as the total number of incoming calls and the average "time to answer," the latter being obtained by measuring the waiting time of four calls in every 25.

It is too early yet to say whether this scheme is successful, or whether the present facilities are adequate. Standardisation of the equipment and, incidentally, more detailed description in this Journal must therefore wait till these points are settled.

J. H. B.

The Packaging of Telephone Exchange Equipment for Long-term Storage in Temperate Climates

G. W. MACKIE and
J. L. CUNNINGTON, Associate I.E.E. †

U.D.C. 621.395.6.004.4: 620.197

This article describes the packaging for storage of telephone exchange equipment provided for emergency purposes. A statement of the general requirements is made, followed by details of the packing cases, case liners, desiccant and humidity indicator, etc., which are necessary to provide for effective protection against physical damage and deterioration of the equipment. Information is also included on the methods of packaging applicable to the various classes of equipment to be stored.

INTRODUCTION

FOR many years it has been the practice to store telephone exchange equipment for use in the restoration of service following an emergency, and during the war years the holdings of such emergency equipment were greatly increased. The equipment was packed in the normal manner in wooden cases and, due to shortage of accommodation, often had to be stored in unsuitable buildings.

After the war, inspection showed that equipment stored under adverse conditions for several years exhibited marked signs of deterioration, apart from physical damage caused by inadequate packing and mishandling. In particular, the ingress of moisture had caused corrosion of metal parts, mould growth on textile-covered wires and reduction of insulation resistance.

It was decided, therefore, to investigate the whole problem of packaging for long-term storage; the emergency stocks were to be replenished and then packed so as to ensure reasonable immunity from atmospheric and other hazards.

The Ministry of Supply, in conjunction with the three fighting Services, had already conducted considerable research into methods and materials used in packaging and had recommended certain standards of packaging for different classes of equipment and stores. These standards are designed primarily for the protection of equipment and stores during transit to their destination and for short-term storage only; they are also designed to meet extremes of temperature and relative humidity. The method adopted by the Post Office for the packaging of the emergency exchange equipment is a variant of the standard method and is designed for a storage period of five years or more in temperate climates.

A number of proprietary methods of protective packaging were considered, e.g. enclosing in a plastic skin by dipping or spraying processes, but were rejected for economic or other reasons.

REQUIREMENTS OF PACKAGING

The packaging of emergency telephone exchange equipment should meet the following requirements:—

Protection from Physical Damage.

The use of a stout, well-designed case is necessary to protect the contents from external damage; in addition the contents must be secured to prevent movement within the case, as such movement is a frequent cause of damage.

Protection from Water and Moisture Vapour.

It is relatively easy to arrange for a packing case to be waterproof but, short of providing it with a completely sealed metal liner at a prohibitive cost, it is impossible to make it completely moisture vapour proof. Various materials can be used as case liners to reduce the ingress of moisture vapour to a low figure.

Maintenance of Low Relative Humidity within Case.

Air normally contains moisture in the form of water vapour and at any given temperature it can only hold a limited amount of such vapour. The higher the temperature the more water vapour the air can hold and any lowering of the temperature will cause some of the moisture to be given up in the form of water. The amount of moisture in the air is expressed in terms of percentage relative humidity; saturated air is said to have 100 per cent. R.H. whilst completely dry air is at 0 per cent. R.H.

The Ministry of Supply has conducted considerable research into the effects of temperature and R.H. on corrosion of metals and the results indicate that to ensure freedom from corrosion and mould growth it is necessary to prevent the R.H. of the air rising above 50 per cent. at normal temperatures.

The air within the packing cases can be kept below 50 per cent. R.H. either by storing the cases in humidity-controlled buildings, or by providing an effective moisture vapour barrier and a desiccant to absorb the small amount of vapour which penetrates the barrier. The equipment concerned is to be stored in Supplies Department buildings which are not humidity controlled and the moisture vapour barrier method has therefore been adopted.

Humidity indicators are required in the cases containing apparatus racks and manual positions. These indicators can be read from outside the cases, thus allowing a constant check to be maintained on the R.H. within the cases.

Suitability for Handling by Fork Lift Trucks.

In the Supplies Department's depots the cases are handled entirely by fork lift trucks which necessitates the addition of certain fittings to the cases to enable them to be lifted without being damaged. Also the provision of corner blocks on the cases is necessary so that they can be stacked without palletising.

PACKAGING MATERIALS

The various types of equipment to be stored need different classes of packing. Thus, apparatus racks, manual switchboards and similar items are packed in cases with a moisture vapour barrier in the form of a case liner, a desiccant and a humidity indicator. For ironwork (e.g. unequipped M.D.F.s and I.D.F.s) cases fitted with waterproof liners only are suitable. Relay sets and selectors are stored individually in cartonboard cartons, sealed, with desiccant, in a moisture vapour barrier overwrap and packed in wood wool, the case having a waterproof liner.

The Ministry of Supply has produced a series of standard specifications for the materials to be used in packing and for the construction of standard packing cases. Wherever possible these specifications have been followed for the packaging of the telephone exchange equipment.

In the following paragraphs some details are given of the materials used and their application.

Packing Cases.

The packing cases are constructed from exterior grade, resin-bonded plywood, $\frac{5}{8}$ in. thick, suitably battened

† The authors are, respectively, Executive Engineer and Assistant Engineer, Exchange Equipment and Accommodation Branch, E.-in-C.'s Office.

to give adequate protection from physical damage. The insides of the cases are perfectly smooth and free from projections which might damage the case liner. All joints in the cases are waterproofed by the application of "Bostick C" or other similar waterproof adhesives. The lids are secured by captive screw fittings to facilitate removal and subsequent refitting.

Fig. 1 shows a packing case for an 8 ft. 6 in. × 4 ft. 6 in.

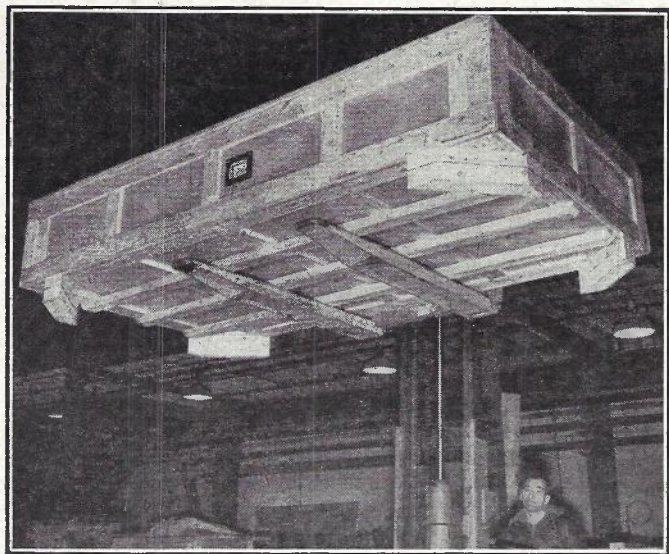

FIG. 1.—CASE CONTAINING 8 FT. 6 IN. × 4 FT. 6 IN. APPARATUS RACK, RAISED ON A FORK-LIFT TRUCK.

apparatus rack, lifted ready for stacking. Corner blocks, 5 in. × 4 in., are fitted so that the case may be stacked by the fork lift truck without the use of pallets; the base is strengthened with 4 in. × 2 in. battens or "skids" to permit lifting by this means without danger of crushing the bottom of the case. In the centre of the case is a window of $\frac{3}{8}$ -in. Perspex through which the humidity indicator is inspected.

Moisture Vapour Barrier Case Liner.

It has been mentioned that in packing cases containing apparatus racks it is necessary to maintain the relative humidity at 50 per cent. or below. Cases will be stored in premises which are not humidity-controlled and the R.H. will probably vary between 40 and 75 per cent. It is therefore necessary to reduce to a minimum the movement of air, with its moisture content, from the outside to the inside of the cases. This is the function of the case liner. It is necessary to have some yardstick to determine the amount of moisture vapour a material will pass in a given time and this is expressed in grammes of moisture vapour passed per square metre of the material in 24 hours under certain specified test conditions (the Moisture Vapour Transmission Rate of the material). The test conditions laid down by the Ministry of Supply are, very briefly, that a 6-in. square of the material under test shall be used as a lid on a dish containing anhydrous calcium chloride and the dish shall be exposed to conditions of $100 \pm \frac{1}{2}$ °F and 90 ± 1 per cent. R.H. The dish is to be weighed every 24 hours and when a constant increase of weight is obtained this will be taken as the M.V.T.R. of the material under test.

The M.V.T.R. of a case liner should not exceed 1 gm/sq.metre/24 hours as otherwise the amount of desiccant required to control the R.H. inside the case becomes unwieldy. The material used to make the case liner is metal foil laminated sheet (heat-sealable) and is manufactured in accordance with a Ministry of Supply

specification. It consists of a ply of metal foil laminated with one or more plies of paper, cellulose film fabric, or other suitable material. The type used in the packaging under discussion has a ply of scrim to give it the required mechanical strength. The metal foil, generally commercially pure aluminium, is coated on its exposed surface with a compound which is heat-sealable under pressure, to give a good joint and seal between two pieces of the material. An ordinary heat-controlled domestic flat iron can be used for this purpose, although specially designed irons are on the market. The seal must not be more permeable to moisture vapour than the material itself. Generally speaking, a temperature of 160°–180°C is required for satisfactory heat-sealing.

Metal foil laminated sheet is obtained in rolls 2 ft. or 3 ft. wide, and the case liner is constructed by heat-sealing lengths of the material together, with a 4-in. overlap, to form sides, ends and bottom. Great care has to be exercised in the preparation of the liner, which is prefabricated on a former, all corners being slightly rounded. Care is also necessary to avoid unduly creasing the material which has a tendency to crack and become pinholed. A window is formed in the liner to coincide with the window in the case and is covered by $\frac{1}{16}$ -in. Perspex sheet directly heat-sealed to the liner. After forming, the liner is carefully fitted into its case and, when the case has been packed, a lid of the metal foil laminated sheet is heat-sealed to the top edges of the case liner, thus effectively sealing the contents of the case.

Moisture Vapour Barrier Wraps.

Small items such as relay sets are packed in cartons, with silica gel and then wrapped in a moisture vapour barrier of 0.01-in. polythene sheeting. Polythene is tough, has high chemical resistance and, for the 0.01-in. thick sheeting, gives a M.V.T.R. of 2–3 gms/sq.metre/24 hours. It is not damaged by creasing; in its thinner sheeting, 0.01 in. and less, it is transparent and is readily heat-sealed. The heat-sealing technique is different from that required for metal foil laminate in that the polythene must be allowed to cool under pressure after being heated to about 300°F and sealed under pressure. Commercial heat-sealers are available with sealing jaws which apply the correct pressure, and the heating and cooling times are automatically controlled. Polythene has the disadvantage of tending to stick to the jaws of the heat-sealing machine, but this is overcome by the insertion of strips of "Teflon" (polytetrafluoroethylene) between the jaws of the machine and the polythene sheet.

Waterproof Case Liners.

Cases containing ironwork only, or relay sets and selectors which are already protected by their polythene overwrap, are fitted with a waterproof liner consisting of two sheets of creped kraft paper laminated with an adhesive and reinforced with strands of sisal or hemp fibre. This paper is tough and waterproof, but its M.V.T.R. is relatively poor.

The kraft paper is stuck to the inside of the case with an approved adhesive and after the case has been packed, a lid of the paper is fixed in position and stuck to the top edges of the case liner.

MOISTURE ABSORPTION

The desiccant used is silica gel which can absorb large amounts of water; is chemically inert and non-corrosive; remains solid whilst absorbing moisture; and can be re-activated. Silica gel can be obtained in muslin bags of various capacities and must be stored in either airtight drums or in ovens maintained at a temperature of 160°F or over. In the packaging covered in this article, 8-oz. bags of

silica gel are specified*, and to prevent deterioration it is of course necessary to ensure that a minimum period of time shall elapse between taking them out of store and sealing them in the packing cases concerned. For cases containing apparatus racks this period is specified as 10 minutes.

The moisture to be absorbed can come from three sources:—

- The air inside the case when sealed.* This air contains some moisture, but it is very little and not important.
- The air outside the case.* This is the most important source of moisture and the amount that percolates into the case will depend upon the efficacy of the moisture vapour barrier, already described, and on the difference between the R.H. inside and outside the case.
- Packing material (dunnage).* Dunnage used inside the case to prevent movement of the contents, or for protection, can be a considerable source of moisture as most of the materials for this purpose are hygroscopic. By the use of metal packing irons, as described later, the amount of hygroscopic dunnage in cases containing apparatus racks has been virtually reduced to zero.

The amount of silica gel to be inserted in the packing cases is determined from empirical formulæ. For temperate climates, and for storage in normal buildings, the formula is:—

$$W = \frac{ARM}{360} + \frac{D}{5}$$

where

- A* = Area in square feet of sealed case liner.
- R* = Moisture Vapour Transmission Rate of liner.
- M* = Time in months for which cases are to be stored.
- D* = Weight of dunnage in pounds.
- W* = Weight of silica gel in pounds.

To obtain the best results the desiccant must be distributed throughout the case, the individual bags being securely tied in position.

Humidity Indicators.

Various types of humidity indicator were considered but the only one that could be guaranteed to function over long periods was the paper type, which indicates changes of R.H. by changing colour. The indicator used is shown in Fig. 2;

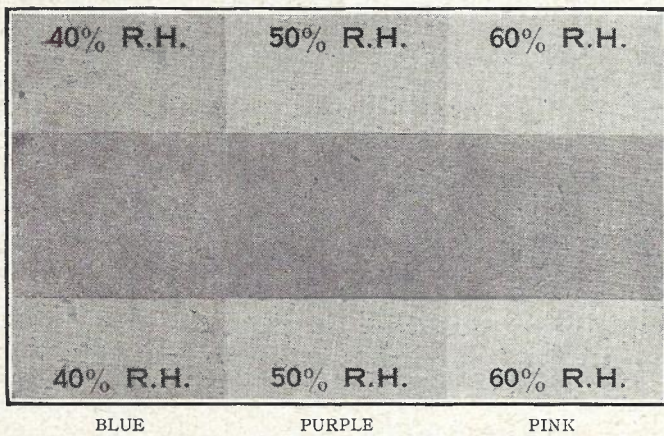

FIG. 2.—THE HUMIDITY INDICATOR.

the centre indicating paper, both faces of which are exposed, is impregnated with cobalt chloride which is blue at low R.H. and changes through purple to pink at high R.H. Flanking the paper at top and bottom are reference colours indicating the colour the paper will be at 40, 50 and 60 per cent. R.H. Thus, a comparison of the colour of the paper with the reference colours will give an indication of the R.H. inside the case. The humidity indicator is fixed to the inside of the window in the case liner.

Apparatus Racks.

In the packing of an 8 ft. 6 in. × 4 ft. 6 in. relay set rack six "packing irons" are bolted to the rack, three per upright. These packing irons take the weight of the rack and, being bolted to the sides and bottom of the packing case, prevent movement within it. As previously stated, the use of packing irons obviates the need for hygroscopic dunnage such as wood chocks or battens. All sharp corners on the rack which might pierce the case liner are padded with waterproof adhesive tape and this tape is also used to secure in position any item on the rack which might work loose.

Fig. 3 shows the relay set rack in the case with the packing

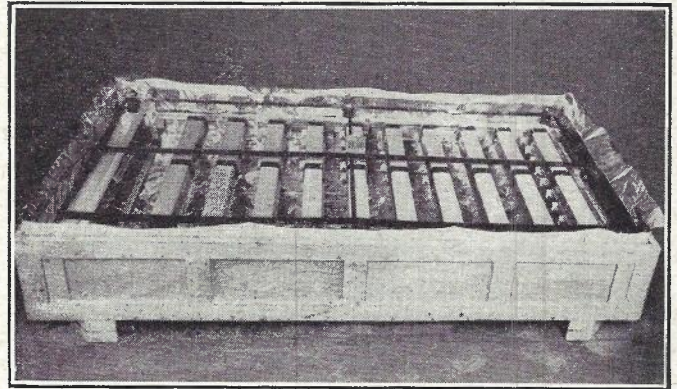

FIG. 3.—APPARATUS RACK IN CASE, SHOWING PACKING IRONS AND WATERPROOF ADHESIVE TAPES.

irons bolted to the sides and bottom. The use of cork gaskets and waterproof adhesives, renders the bolt holes, in the case and liner, waterproof and also reasonably moisture vapour proof. Across the top of the three pairs of packing irons are bolted metal bars with three longitudinal rows of waterproof adhesive tape. The bars and tapes are provided for the lid of the moisture vapour barrier liner to rest on and to prevent it coming into contact with any sharp corners.

Fig. 4 shows the moisture vapour barrier lid being heat-

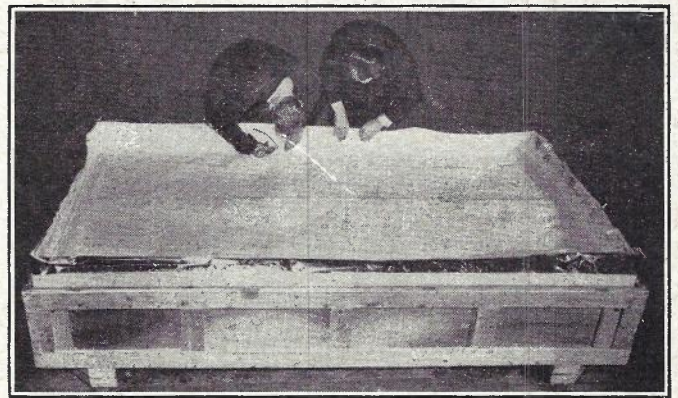

FIG. 4.—SEALING MOISTURE VAPOUR BARRIER LID IN POSITION.

sealed into position. At this stage the silica gel has been inserted and the packing is nearing completion. When the sealing has been almost completed, the nozzle of a household type vacuum cleaner is inserted in the liner and the air sucked out until the lid settles down on the bars and tapes. The nozzle is then withdrawn, the sealing completed and

* Silica gel impregnated with cobalt chloride to act as a humidity indicator is not suitable as dust from this form of the desiccant settling on metal surfaces accelerates corrosion.

the wooden lid screwed into place, thus completing the packing of the rack.

The above procedure applies to all cases with contents requiring full protection, though, of course, the shape and size of the packing case, packing irons, etc., will vary.

Relay Sets and Selectors.

Relay sets and selectors are packed 50 per case, the case having a waterproof liner but no humidity indicator as each item has its separate moisture vapour barrier overwrap. After being lined, the packing case has a 3-in. layer of wood wool placed in position, followed by the layers of relay set cartons, usually 25 per layer. Around the sides and top of the cartons wood wool is firmly packed in position, so that at any point there is a 3-in. layer thereof between the relay set cartons and the case. A lid of the waterproof liner material is stuck with a suitable adhesive to the top of the liner and the wooden lid secured in position by captive screw fittings.

IDENTIFICATION OF CASES AND CONTENTS

Codes are stencilled on the cases to convey to the controlling officers in the Engineering Department the storage location, contents and serial number of the cases; for the benefit of staff in the field, the cases are also stencilled with a description of their contents and relative diagram and drawing numbers. The gross weight is also shown, as this information is essential when making transport arrangements or handling on site.

ACKNOWLEDGMENTS

The advice and help given by members of the Ministry of Supply, the telephone manufacturers and the Post Office Supplies Department during the investigations into the packaging of the emergency telephone exchange equipment and its subsequent handling and storage, is gratefully acknowledged by the authors.

The photographs illustrating this article are reproduced through the courtesy of the General Electric Co., Ltd., and the Post Office Supplies Department.

Inter-Office Telephone System for the Postmaster-General

FAMILIARITY breeds contempt and it is often to be found that the craftsman perfects his art for the benefit of others, but rarely applies it to his own needs. It was not surprising therefore to learn that the telephone arrangements for the office of the Postmaster-General consisted of a somewhat complex assembly of telephones which would rarely be tolerated by an ordinary subscriber, except perhaps by the few to whom the number of telephones per desk spelt importance.

Replacement by a more compact and efficient system was long overdue but orthodox equipment could not provide the facilities required. This, and the singular importance of the office concerned, gave an opportunity for unique approach. At least as far as physical design was concerned, here was an opportunity to produce equipment of pleasing appearance, which in these days of continued austerity we are unable to do in the general case.

Briefly, it was stipulated that the eight incoming circuits should be fully available to four secretaries, with connection to the Postmaster-General or Assistant Postmaster-General as required. The office equipment was to be limited to a control panel and telephone per secretary, the Postmaster-General and Assistant having one telephone each. Operating was to be kept to a minimum and calls to be self-clearing.

As can be seen from the illustration, the control panels differ considerably in appearance from the familiar type of Post Office switchboard. They are basically of wood, with front and back covered in bird's-eye maple Waverite veneer. The sides and lower front are contrasted in black enamel and the curved fluted top is finished in cream to match the background colour of the Waverite. The front slopes back at about 80°. A translucent strip suitably engraved and illuminated from the rear replaces the conventional lamp signals. Provision is made for engaged signals because all circuits are ancillared over the four

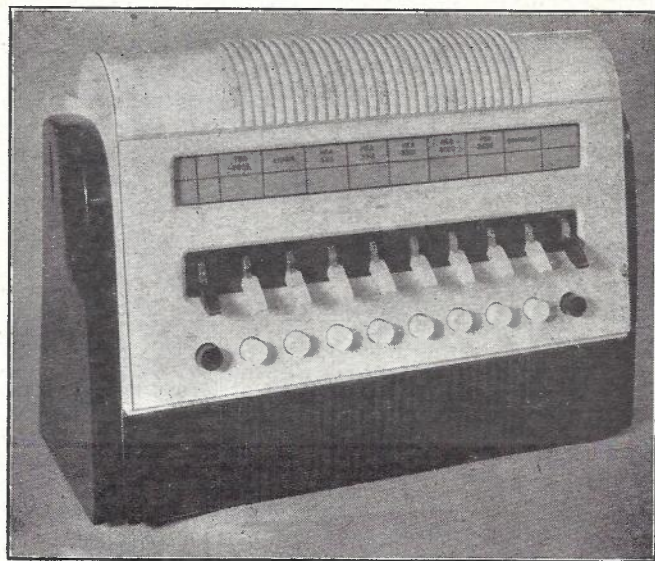

CONTROL PANEL FOR POSTMASTER-GENERAL'S OFFICE.

panels. The lever keys are conventional Post Office type but specially moulded square handles have been used. These keys are normally in the downward position, are mid-way in the "speak" position and upwards in the "hold" position. The press-button keys, which when operated connect the associated circuits through to the Postmaster-General or Assistant Postmaster-General, are of Ericsson manufacture.

The control panels were designed in detail by Ericsson Telephones, Ltd., who also manufactured the associated switching equipment. The equipment was installed by the London Telecommunications Region.

U.D.C. 621.316.89

To satisfy certain circuit requirements it may be convenient to make use of a device whose resistance rapidly falls to a low value as its temperature increases. Such a device, known as a thermistor, can be made from semi-conducting materials, and this article gives a brief account of its production on a commercial scale. Two important circuit applications are referred to, one using a Bead-type thermistor and the other a Rod-type.

Introduction.

MATERIAL used in electrical circuits can be divided into three classes: conductors, semi-conductors and insulators. While the first and third groups have been used widely in the whole of electrical history, only a limited use of the second group has been made until recently, though the rate of application is increasing rapidly.

A thermistor is a device made from one form of semi-conductor whose specially interesting characteristic is that its rate of change of resistance with temperature is much greater than that of conductors, and so great that many useful applications can be made of it. While the resistance of a conductor increases with rising temperature, generally proportionally to the absolute temperature, the resistance of a semi-conductor decreases with rising temperature according to a relationship

$$R_T = R_0 e^{-b/T}$$

where R_T is the resistance at temperature T ,

b is a constant,

e is the base of Napierian logarithms.

While many semi-conductors may show very interesting and useful properties by having non-ohmic resistances, the thermistors that have been developed are essentially ohmic, that is E/I (where E is the applied voltage and I the current) is constant for all values of E at constant temperature.

Thermistor Material.

The development of thermistors within the laboratories of Standard Telephones and Cables Limited has been carried out continuously over a period of nearly 20 years, and many materials have been investigated and tried out in fairly large-scale tests during that period. To-day all the various types of material except one have been discarded for one or another reason, and large-scale production of a wide variety of thermistors is now carried on with this successful material. The basic material is a mixture of metallic oxides, which is fired in air to a very high temperature to give it the desired characteristics. The metals used are ones having several valencies, such as nickel, and by the use of appropriate binary or ternary mixtures, and by variations of firing technique, a range of final materials can be produced, each of whose resistivity varies over a ratio of the order of 10,000 within practicable operating limits of temperature. More important is the fact that any desired result can be regularly and reliably achieved with a reasonable and practical amount of technical control.

These materials have very useful characteristics. For those with the higher values of resistivity the temperature coefficient of resistance at room temperature is of the order of 4 per cent. per °C, this coefficient being smaller for the lower resistivity materials. They are free from all rectification effects in A.C. circuits and are unchanged by heating in air or oxidising atmospheres, but may be adversely affected by heating in reducing atmospheres. The materials are also non-magnetic and their A.C. and D.C. resistances are alike up to very high frequencies. Most types of thermistors show a good degree of stability of resistance with time.

Types of Thermistor.

There are three main types of thermistor in regular production: Bead types, Pellet types and Rod types. Only the methods of producing the first and last will be shortly described here.

The bead types are many in number. All essentially consist of a minute bead of thermistor material formed on to two closely adjacent platinum wires. They may finally be of directly-heated or indirectly-heated design, but the main production processes being similar, the directly-heated type will be described here.

The pellet types are, as the name describes, pellets of material usually up to about $\frac{1}{2}$ in. in diameter and up to $\frac{1}{8}$ in. thick, silvered on the flat faces for connection easily into circuits, and in some cases soldered on to brass base-plates.

The rod types are circular rods up to $\frac{1}{4}$ in. in diameter and any desired length, usually up to about $1\frac{1}{2}$ in. These may be silvered at the ends for insertion into clips, or they may be supplied with wire ends.

Uses of Thermistors.

It is not proposed to describe the very wide field of application of thermistors, but some uses have developed to the extent where very large quantities are used and large-scale manufacture has been introduced. For illustration, therefore, two cases are taken to show the diversity of application.

Firstly, we can consider the type of rod thermistor known as the "Brimistor." This has been specially developed to be used in broadcast receiver sets and television sets, in which valves are heated in series. As is well known, the ratio of the hot to cold resistance of a valve heater is quite large, and at the instant of application of voltage to a cold heater a heavy current surge passes. This in itself may be of little importance, but, when valves are heated in series, conditions can often arise where some heaters may be temporarily very severely overheated and short life can result. The use of a Brimistor in series, which has initially a resistance high enough to suppress the surge, will enable all the heaters to come to working temperature without any danger of quick-heating valves being overheated. After a few seconds the resistance of the Brimistor falls to a value which is negligible in this circuit. In this case the device has to be suitable to carry the heater current continuously and massive enough to take some seconds for the resistance to fall to the working value.

Secondly, we can look at a very widely different application in the British telephone network, where the G.P.O. thermistor type 1A is employed in shared-line service to suppress bell tinkling. In this application, the thermistor has to remain at a sufficiently high resistance to suppress bell tinkling while dialling impulses are incoming, but fall to such a low resistance as not to interfere with bell ringing within a ringing cycle. This requires that the thermistor shall be very quick heating, so the bead must be very small and the rate of loss of heat by conduction down the leads must also be reduced.

† The author was Chief Valve Engineer, Standard Telephones & Cables, Ltd., until his untimely death on 27th December, 1952.

Manufacture of "Brimistors."

The raw materials for the rods are nickel, manganese and copper oxides, which are prepared in the correct chemical form and in a fine state of division, and these properties are first checked.

The materials are then weighed out in the necessary quantities and mixed with distilled water to a slurry which ensures thorough blending of the components. When mixing is complete, the water is filtered off and the filter cake dried and pulverised, and stored in hoppers.

When required, the dried powder is mixed with suitable binding agents and thoroughly worked to a stiff dough. This is transferred to an extruding machine where it is vacuum de-aired prior to extrusion. Fig. 1 shows a length

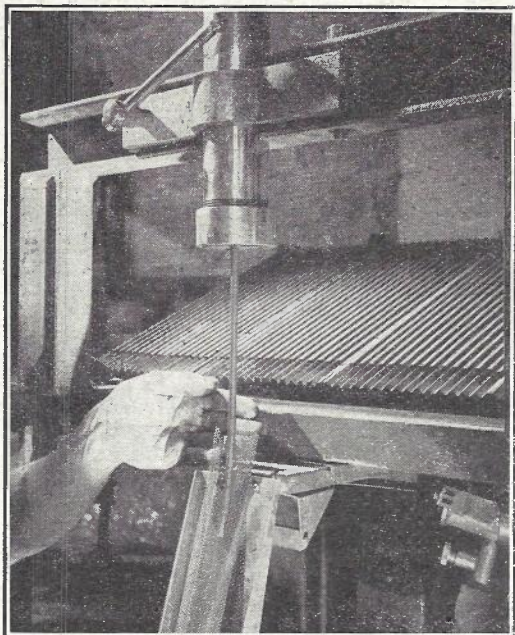

FIG. 1.—MATERIAL FOR BRIMISTORS BEING EXTRUDED VERTICALLY.

of material being extruded vertically. At this stage the material is soft and putty-like, and is easily cut into short lengths suitable for the finished Brimistor. A few days' curing changes it to a dry material hard enough to withstand subsequent handling. Fig. 2 shows trays of cured material.

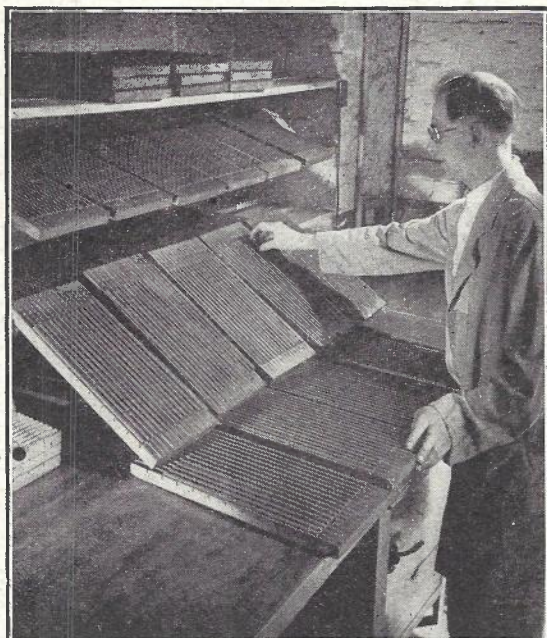

FIG. 2.—TRAYS OF BRIMISTOR MATERIAL AFTER CURING.

From this stage the material proceeds to the firing which is carried out in two stages, according to a carefully controlled time and temperature schedule, in the ovens shown in Fig. 3. During this process the material shrinks con-

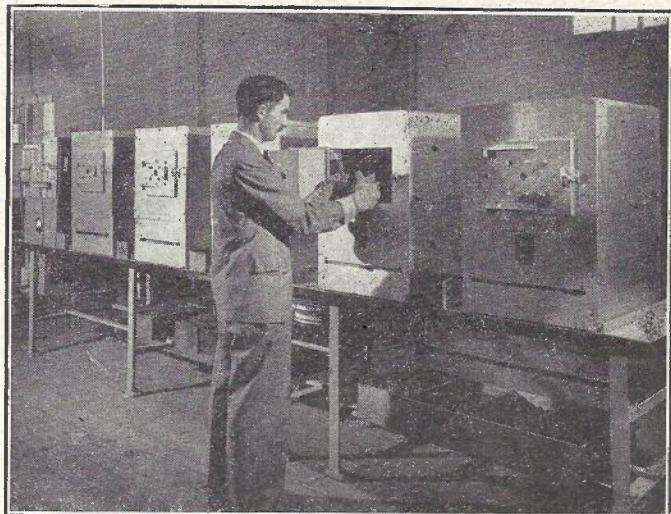

FIG. 3.—FIRING OVENS.

siderably, becomes so hard that a rod can no longer be broken by hand, and acquires the desired electrical properties.

In order to be able to connect the thermistors into circuits, they are then silvered at each end, the silver being fired on in a conveyor furnace, and wires are soldered to the silvered ends, as shown in Fig. 4. Manufacture is completed by mech-

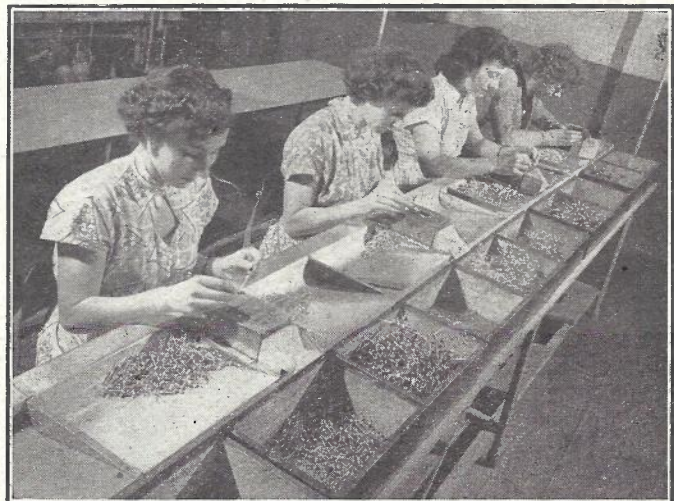

FIG. 4.—SOLDERING WIRES TO BRIMISTORS.

anical tests for dimensions, strength of end connections, etc., electrical tests of performance and resistance, followed by packing.

Manufacture of 1A Thermistors.

In this thermistor the circuit requirements can only be achieved with a bead, roughly spherical in shape and only a few thousandths of an inch in diameter. Because of the firing conditions, which are in the order of 1,200°C in air, the only practical supporting wires are platinum or platinum alloys. The time-constants desired in the thermistor, and other characteristics necessary to ensure that the thermistor works properly in the subscriber's set over a very wide range of ambient temperatures, impose further limitations on the particular platinum alloy, its diameter and length.

It is possible to use platinum wires of about 0.002 in. diameter, or an alloy such as platinum-iridium with a diameter of only 0.001 in.

Two of these wires about 6 in. long are mounted on a frame which spaces them the correct small distance apart, and holds them parallel under light tension.

The process of making the beads is carried out by hand. It is a highly skilled one and is illustrated in Fig. 5. The

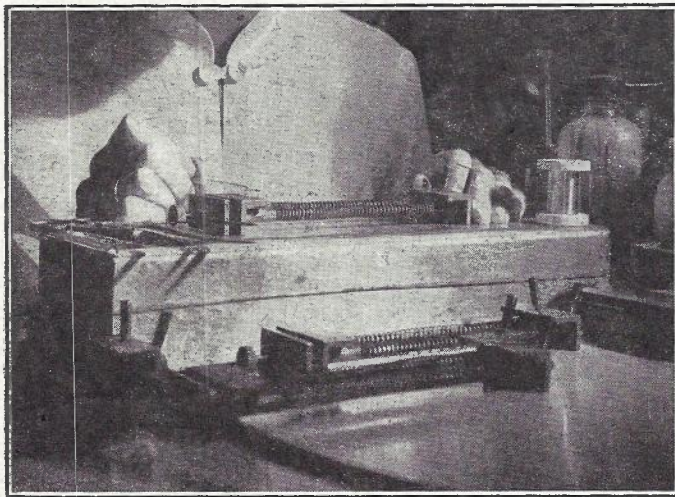

FIG. 5.—PLACING THE MIXTURE TO FORM BEADS FOR 1A THERMISTORS.

oxides are mixed as fine powders in the correct proportions, together with suitable binders. These are kept mixed in a small agate mortar and the consistency is continually adjusted as necessary to maintain the proper viscosity and surface tension. Minute drops of the mixture are picked up on a glass rod and applied at about $\frac{3}{4}$ in. spacing to the platinum wires. If the physical properties have been properly adjusted, then the drop can be made to take up an ellipsoidal shape symmetrically placed on the wires and of the correct size. The close requirements on the final article allow very little latitude in the consistency of the material.

After drying, the beads are stiff enough to permit the wires being cut from the sprung frames, and the beads are then fired by pulling them through a vertical tubular furnace with platinum heating elements. When they have been fired, the beads are extremely hard and have shrunk appreciably. The wires are now cut close to one side of each bead so that there are two short wire leads with a bead joining their ends. The ends of the wires are welded to a cunife hairpin under a spot welder, thyatron controlled to give exact electrical conditions, and pressure controlled to give exactly reproducible mechanical conditions. This operation is seen in Fig. 6. The loops are then sealed into small glass tubes and tipped off, and the bend of the hairpin is cut off.

In order to stabilise the thermistors, they are aged under conditions more stringent than those met with in service, and are then ready for final inspection. This is shown in



FIG. 6.—WELDING WIRES OF 1A THERMISTOR TO A CUNIFE HAIRPIN.

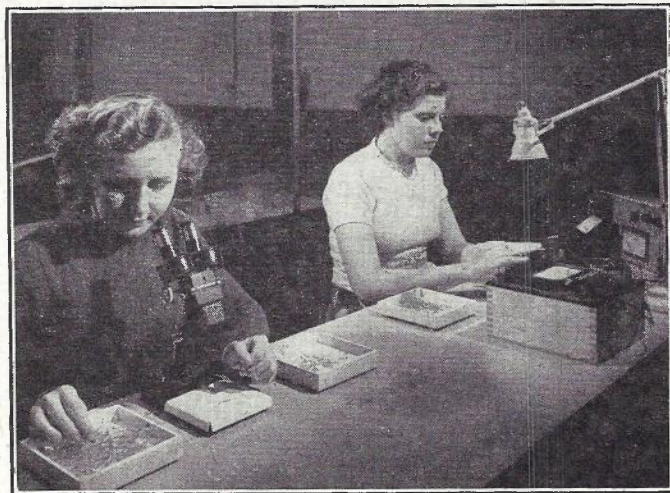

FIG. 7.—FINAL INSPECTION OF 1A THERMISTORS.

Fig. 7. The inspection process includes mechanical inspection of the bead and welds under a binocular microscope and electrical testing appropriate to its special application.

Throughout all the operations very close attention to cleanliness and technical control of conditions is essential to ensure meeting the requirements. The rate of change of characteristics with chemical condition of the bead, firing schedule and other variables is so rapid that, without such control, regular production of these thermistors would not be a practical proposition.

Acknowledgments.

The author would like to thank colleagues associated in this work, and especially Mr. H. Wolfson, for their great assistance, and Standard Telephones & Cables, Ltd., for permission to publish this paper.

Book Review

"Remote Control by Radio." A. A. Bruinsma. Phillips' Technical Library Popular Series. Distributed by Cleaver-Hume Press, Ltd., London. 96 pp. 74 ill. 8s. 6d.

This book contains some useful advice and information for the designer and constructor of radio-controlled models. In the first of two remote-control systems which are described, channels for controlling the motor and rudder of a model ship are provided by amplitude-modulating a 100-Mc/s carrier. A

second system incorporates eight-channel pulse amplitude modulation on a 100-Mc/s carrier and is used to control a larger model vessel and an attendant ship-based aircraft. Detailed circuit explanations and full data of the manufacturer's valves are included. The translation from the Dutch is imperfect, but not seriously misleading. Modellers should note that in the United Kingdom a radio frequency of 100 Mc/s may not be used for model control; the appropriate frequencies can be ascertained from Post Office Engineering Department headquarters, London.

D. B. B.

The Use of Dry Cells in Subscribers' Premises

R. Collings and F. G. Jackson†

U.D.C. 621.352.7:621.395.721.1

Subscribers' local speaking batteries will be of the dry-cell type in future installations, and existing wet-cell batteries will be gradually changed over to dry cells. The authors explain how this policy has been determined from the results of an extensive field trial of dry cells in subscribers' premises.

Introduction.

THE Post Office adopted wet Leclanché cells as standard for subscribers' local speaking batteries when the first Post Office telephone exchange was opened at Swansea, in 1881. At that time the wet cell was the natural choice because the development of the dry cell was insufficiently advanced for it to be a reasonable alternative. Later, however, their general convenience stimulated the production of cheap and reliable dry cells, and in 1938 it was decided to carry out a field trial to investigate the relative engineering and economic merits of wet and dry cells.

Field Trial.

The South-Western Region (then the South-West District) was chosen for the field trial and all stations in the chosen exchange areas were provided with new primary batteries. One-half of these were standard wet-cell batteries and the other half were dry cells fitted in a standard battery box. Immediately after installation, tests were made and the condition of each battery recorded. These were the usual tests which give an indication of the internal resistance and the condition of the depolariser, as well as the E.M.F. of the cell. The tests were repeated on subsequent maintenance and faulting visits. It was intended that this should give a history of wet-cell and dry-cell batteries working under comparable conditions, the records being kept on subscribers' fault cards. Unfortunately the outbreak of war coincided with the start of the trial in September, 1939, and the required high standard of records and attention could not be maintained; neither could periodical Engineering Department visits be made. Thus, when a check was made in 1946, considerable care had to be taken to exclude installations which were no longer equipped in accordance with the information on their fault cards.

Although records indicated that the dry cell was the better economic proposition, the shortage of dry cells made it impracticable to extend their use at that time; it was decided, therefore, to continue the trial under the better post-war conditions. Meanwhile, independent reports were made by several centres suggesting that the dry cell was preferred by both subscribers and maintenance staff. The main points made were that the dry cell had a long life and that it could cause no damage to subscribers' property if upset.

The trial was concluded in 1951. All details of trial batteries were extracted from the fault cards and analysed to determine various factors, such as the life of cells and the cost of maintenance attention necessary to prevent faults. The economic merits of the two types of cell were then compared. The comparison showed that the dry cell was the better proposition, because the reduced cost of faulting and routine maintenance offset the greater initial cost of the dry cell.

Routine Maintenance of Dry Cells.

(i) *Main telephone installations.* If visits for routine maintenance were ceased entirely, battery deterioration

would cause poor transmission and eventually a fault would be reported. It is necessary, therefore, to consider the frequency of routine maintenance visits in relation to the faults likely to occur, and from the field trial data the following information was obtained:—

Battery failures prevented by a visit after

1 year	= 100 per cent.
2 years	= 100 per cent.
3 years	= 100 per cent.
4 years	= 93 per cent.
5 years	= 78 per cent.
6 years	= 44 per cent.

These figures suggest that a visit after four years is desirable. A check of subscribers' fault cards revealed, however, that 41 per cent. of all local battery subscribers' premises are visited in any year for reasons other than battery maintenance. It would, therefore, appear reasonable to replace cells at the first normal maintenance visit after the end of the four-year period. Although a number of subscribers whose batteries would be due to fail would not be visited under this arrangement, the resulting fault rate was calculated to be less than 0.1 fault per telephone per annum. This is considered acceptable.

The cost of a single special maintenance visit exceeds the residual value of dry cells which may be fit for further service after four years. It is, therefore, cheaper to replace cells known to have passed the minimum exhaustion date than to make periodic visits for testing purposes.

(ii) *Extension Telephones.* Local batteries fitted on subscribers' Extension Plan Nos. 5 and 7 for speaking from the main to the extension telephone are not used so much as are local batteries for speaking on exchange connections. Furthermore, a lower standard of transmission can be tolerated on these local and, usually, brief calls from main to extension telephones. Finally, failure of these batteries will only cause a local fault, exchange service being unaffected. It was, therefore, decided that, if these batteries are renewed after six years' service, nearly all failures will be anticipated.

Replacement of Wet Cells.

Having arranged for dry cells to be fitted at new installations and for them to be replaced at regular intervals, retrospective action was considered. A main point of the field trial report was that, to get full benefit from dry cells, all wet cells should be changed to dry. A general retrospective change to apparatus at subscribers' premises would, however, incur heavy expenditure. It was, therefore, necessary to see whether a changeover could be made without extra cost.

It has always been a requirement that batteries should be inspected when an installation is visited for maintenance or faulting purposes. It follows naturally that fitting dry cells (and recovering wet cells) can take the place of this inspection. The time taken to change over to dry cells should be less than that required to renew parts and refresh wet cells.

It is obviously desirable that the changeover should be

† Assistant Engineers, Telephone Development and Maintenance Branch, E.-in-C.'s Office.

completed during a period of four years to fit in with the four-year maintenance cycle, and calculation shows that nearly all cells can be replaced during normal visits over this time. The estimated availability of dry cells is sufficient to meet the increased demands.

Conclusion.

In future, dry cells will be used for all subscribers' local speaking batteries and all existing wet cells will be changed over to dry cells during the next four years. Subsequently they will be renewed after four years' service on exchange

Book Reviews

"The Corrosion Resistance of Tin and Tin Alloys." S. C. Britton, M.A. Tin Research Institute, 1952. 3s. 6d.

This small publication contains 63 pages of information relating to the corrosion of tin and tin alloys. This bald statement does much less than justice to the booklet; it is full of information in a very condensed form and in more spacious times would probably have been twice as big and yet contain no more for the student. One result of this concentration is that the book is not easy to read; although the author has not wasted a word, the information is all there complete with references, in a handy form for the library shelf, but not for the bedside table.

The reader should start with a fair knowledge of corrosion in general, or he will have difficulty in keeping the matter in perspective because the book is admittedly primarily concerned with the qualities of tin products. These are too excellent to be overlooked; consider, for instance, ordinary tinfoil; it carries a coating of less than 0.1 mil and we are satisfied. If we specify electroplated steel for an item, what do we ask for? Not 0.1 mil, but more usually 0.5.

Mr. Britton takes us into some fascinating fields; who would think that photographic developers, if they pass over tin, may cause fogging of the film, that we may have tin amalgam fillings in our teeth, or that, although tin is the metal *par excellence* for conveying distilled water, the murky look of a glass of beer *might* have been due to tin? Even stranger is the fact that ancient bronzes buried for centuries and now carefully preserved in museums may suffer from "museum pest" or "bronze disease" and call for treatment.

The book is commendably free from errors; the only one noticed is in Table II in which the second column headed "Lead" should probably read "Zinc." M. R.

"Television." F. Kerkhof and W. Werner. Philips Technical Library. Distributed in U.K. by Cleaver-Hume Press, Ltd., London. 434 pp. 360 ill. 50s.

This is an excellent book on television produced by engineers of the Philips organisation in Holland and translated into first-class English by some of their associates in this country. It is essentially a reference book for the television engineer, though others interested in the subject will not find it difficult reading. Reference books often have the habit of lying unused on the shelf for long periods, and then failing to give the answer when referred to. Not so this volume, which, in a matter of a few months, has supplied the reviewer with answers to numerous questions that have arisen in the course of duty.

The first chapter gives a general review of the processes involved in television broadcasting from the camera to the viewer's picture tube. This is followed in succeeding chapters by detailed descriptions covering practically the whole field of the art with the notable exception of point-to-point transmission.

The book might well be called an international text-book, for, quite apart from the authorship, it includes descriptions of all the current television systems; the American with 525 lines, the French with 819 lines and the European standard with 625 lines adopted by Holland and certain other countries, together with our own British system with 405 lines. A short chapter near the end also gives brief descriptions of the various systems of colour television that have been demonstrated.

lines, or after six years' service on Extension Plans Nos. 5 and 7.

This policy is only intended to apply to local speaking batteries on telephones, where the dry cell has proved to be a good economic proposition. Wet cells will continue to be used for such purposes as P.M.B.X. batteries.

Among other points of interest which emerged during the trial was the fact that about 40 per cent. of battery faults on local battery telephones, whether using wet or dry cells, were due to disconnected battery leads. A new method of wiring, using a flexible cord, has now been introduced and this type of fault should be greatly reduced.

In addition to the full analysis of the various component sections of a television receiver, the final chapter gives detailed descriptions of two television receivers, one suitable for the British system, complete with parts list and full circuit diagram.

The appendix includes a useful glossary of television terms and a list of references, while the final pages are devoted to a series of photographs illustrating receiver maladjustments and various forms of interference. One small note of criticism—the index is not right at the end of the book and so is a little difficult to find in a hurry. Nevertheless this book will prove extremely valuable to the television engineer. T. K.

I.P.O.E.E. Library No. 2061.

"Applied Electricity." H. Cotton, M.B.E., D.Sc., M.I.E.E. Cleaver-Hume Press, Ltd. 451 pp. 17s. 6d.

The name of Dr. Cotton, the author of a number of our most widely used text-books on electrical engineering, must be familiar to most readers of this journal. His first book, "Electrical Technology," published in 1930, was quickly adopted as a standard text-book by many of our engineering colleges, and his latest book, "Applied Electricity," is clearly developed from this first and successful volume. More simple fundamental theory is included in the new work; magnetism, electrostatics, electrolysis and thermoelectricity are each allocated a whole chapter. Chapters 6, 7 and 8 deal most competently with the principles, performance characteristics and methods of test of the well-known types of D.C. current generators and motors. With the exception of the last four chapters which cover briefly electronics, illumination, measuring instruments and dimensions, the rest of the book discusses A.C. engineering, A.C. circuit theory, transformers, alternators, synchronous and induction motors, and various operating aspects.

The standard reached covers adequately Part 1 of the London B.Sc.(Eng.) degree, or the National Certificates and Diplomas in Electrical Engineering. The book is largely self-contained in that a student can start his electrical studies with this volume. Many illustrative examples drawn from past examination papers are included, and exercises are grouped at the end of the book.

The wide range of the subject matter, and the relatively reasonable price of 17s. 6d., should make this a most attractive addition to a student engineer's library. C. F. F.

I.P.O.E.E. Library No. 2033.

SHORTER NOTICES

"Code for Protection against Lightning." National Bureau of Standards Handbook 46. U.S. Department of Commerce, Washington D.C. 88 pp. 40c.

This handbook is one in the series approved by the American Standards Association. The sponsors are the American Institute of Electrical Engineers, the National Fire Protection Association and the National Bureau of Standards.

"The B.E.A.M.A. Catalogue, 1952-53." Published for the B.E.A.M.A. by Iliffe & Sons Ltd. for private circulation. 1,020 pp.

A buyers' guide to British electrical equipment produced on behalf of the British Electrical and Allied Manufacturers' Association. Glossaries in English, French, German, Portuguese and Spanish are included.

Notes and Comments

New Year Honours

The Board of Editors offers congratulations to the following members of the Engineering Department honoured by Her Majesty the Queen, in the New Year Honours List:—

Glasgow Telephone Area	J. Irvine, M.M.	..	Inspector	British Empire Medal
Gloucester Telephone Area	B. O. Bullard	..	Mechanic-in-Charge, Gde. I	British Empire Medal
Leicester Telephone Area	G. A. Parrott	..	Executive Engineer	Member of the Order of the British Empire
North Western Region	H. G. Davis	..	Chief Regional Engineer	Officer of the Order of the British Empire
Nottingham Telephone Area	H. Cowdell	..	Technician Class I	British Empire Medal
Southampton Telephone Area	F. Coote	..	Area Engineer	Member of the Order of the British Empire

Productivity Team Visit to U.S.A.

A Post Office specialist team under the auspices of the British Productivity Council (successor to the Anglo-American Council on Productivity) left for the U.S.A. on 27th February to study telephone exchange maintenance in the Bell System and independent companies.

The members of the team were: Messrs. R. W. Palmer (Assistant Staff Engineer, E.-in-C.'s office); E. Hopkinson (Area Engineer, Bradford); W. J. A. Hughes (Technical Officer, Southend-on-Sea (P.O.E.U.)); C. Morgan (Technical Officer, Birmingham (P.O.E.U.)); J. Prescott (Area Engineer, L.T.R. Centre Area); and A. C. Young (Assistant Engineer, Brighton (S.T.E.)).

Copies of their report will be available in due course from the British Productivity Council, 21 Tothill Street, S.W.1.

Associate Section (London Centre) Radio Exhibition

In 1952 the enterprising Radio Group of the London Centre, Associate Section, arranged a successful exhibition and demonstration of radio equipment and models in Waterloo Bridge House. The interest then shown has encouraged a further venture of this kind and their 1953 exhibition, to be housed in the Metropole Hall, Northumberland Avenue, W.C.2, will be open to members, friends and the public from 11 a.m. until 8 p.m. on 7th, 8th and 9th May.

Radio Exhibits will be provided by members of the Radio Group of the Centre but the Model section is open to all staff employed in the London Telecommunications Region.

Further information can be obtained from the Secretary of the Radio Group, Mr. H. E. Warren (TEM 1222/437).

Institution of Post Office Electrical Engineers

Associate Section Papers Awards—Session 1951/52

The Judging Committee has selected the following from the papers submitted by the Local Centre Committees, and awards of £3 3s. 0d. and Institution Certificates have been made accordingly:—

- W. J. Costello, Technical Officer, Middlesbrough Centre (N.E.R.)—"Repeater Station Power Plants."
L. S. Hurst, Technical Officer, Lincoln Centre (N.E.R.)—"V.H.F. Aerials and Transmission Lines."
R. T. Hoare, Technical Officer, Gloucester Centre (S.W.R.)—"An Outline of Carrier Telephony."

The Council is indebted to Messrs. C. E. Moffatt, F. E. Wallcroft and M. G. Thomas for kindly undertaking the adjudication of the papers submitted.

H. E. WILCOCKSON,
Secretary.

Additions to the Library

- 2053 *Electromagnetism*. J. Goodier and G. Ghey (Brit. 1952).
An introductory textbook based on the Rationalised M.K.S. system of units.
2054 *Personnel Management and Welfare*. F. H. C. Brook (Brit. 1952).
Enumerates the scope and individual activities of each of the main spheres of action of personnel work.
2055 *Foundations of Electrical Engineering, Vol. I*. H. Cotton and E. W. Golding (Brit. 1952).
A textbook written for students studying for the Ordinary National Certificate in Electrical Engineering; this volume gives a full statement of elementary principles.
2056 *Elementary Mathematics*. L. W. Phillips (Brit. 1952).
Covers the syllabus of the Royal Society of Arts Examination (Grouped Course) in Elementary Mathematics.
2057 *Thermal Properties of Buildings*. N. S. Billington (Brit. 1952).

Brings together the existing knowledge on the subject, and explains the general principles involved.

- 2058 *Television Servicing*. M. Mandl (Amer. 1952).
Written for radio service men, or others with the necessary technical background to understand the discussions involved, who are entering the field of television, and for those already engaged on television servicing.
2059 *Practical Clock Repairing*. D. de Carle (Brit. 1952).
Deals with all the usual faults likely to develop in each type of movement in general use.
2060 *Economical Domestic Heating*. H. G. Goddard (Brit. 1952).
Describes home heating and ventilating from the double aspect of efficiency and economy.
2061 *Television*. F. Kerkhof and W. Werner (Dutch, 1952).
An introduction to the physical and technical principles of television, with comprehensive descriptions of various electrical circuits.
2062 *Mathematics for Telecommunications, Vol. 1*. D. F. Spooner and W. H. Grinstead (Brit. 1952).
Designed mainly for students preparing for the City and Guilds of London Institute examinations.
2063 *The Higher Mathematics*. H. Davenport (Brit. 1952).
An introduction to the theory of numbers.
2064 *Three-phase Motors*. T. F. Wall (Brit. 1952).
A compact and as simple as reasonably possible account of the theory, operation and application of three-phase motors.
2065 *Photography by Infrared*. W. Clark (Amer. 1946).
Assumes some acquaintance with the practice of ordinary photography, and explains the underlying principles, the practice, and the applications of infrared technique in the various fields of science and technology.
2066 *Building Construction, Vol. II*. W. B. McKay (Brit. 1944).
Deals with brickwork, drainage, masonry and mild steel roof trusses.

W. D. FLORENCE,
Librarian.

Regional Notes

Scotland

GALE DAMAGE

Storm damage to overhead plant is unfortunately an almost annual event which does not call for comment unless of an exceptional character, but that which occurred in Scotland on the 31st January was unique. Other years may have produced more spectacular pictures of ice-laden wires, but never has wind alone caused such havoc to pole routes.

From early morning on Saturday, 31st January, 1953, and continuing into the following night, wind velocities sustained at figures around 110 m.p.h., and gusts up to 125 m.p.h. were reported. The damage was almost wholly confined to the Aberdeen and Dundee Areas, the most extensive damage being in Aberdeenshire. Some 200 exchanges were isolated and 8,000 subscribers put out of service.

As usual, fallen trees were responsible for much of the damage, but this time not only were individual trees blocking many roads but complete woods looked more like huge pole stacks than plantations, and it was several days before it was possible to enter some areas to survey the damage.

Elsewhere every wire of heavy routes was blown across the fields and some exchange areas were almost stripped of open wire.

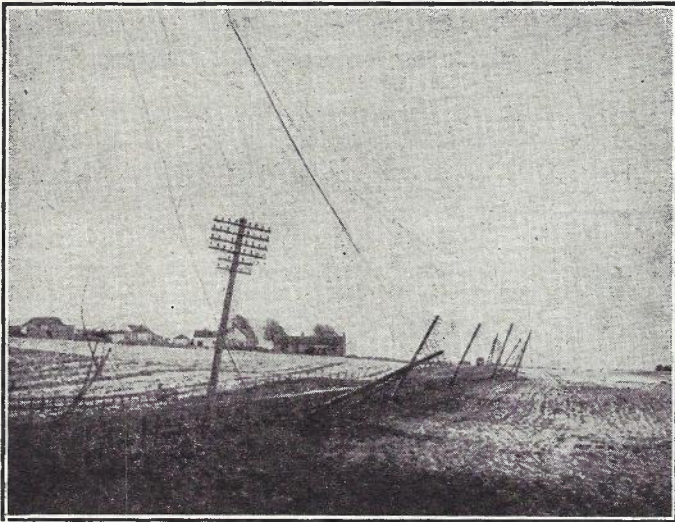

A TYPICAL EXAMPLE OF DAMAGE TO A ROUTE.

It was obvious even while the wind was blowing that repair to the damage sustained was far beyond the unaided resources of the two Areas concerned. On the day following the commencement of the storm (Sunday) a special train with interruption cable and wire was quickly organised by the Supplies Department, and gangs from the south of Scotland started moving into the afflicted Areas. Prompt response from other Regions was made to requests for assistance and within a few days gangs were moving north from Belfast, Brighton, Cardiff, Chester, Exeter, London, Shrewsbury, Newcastle and Taunton.

On 15th February the Engineer-in-Chief paid a flying visit to inspect some of the damage and talked to several of the working parties. It will be many months before it is possible to complete permanent repairs which, without aid from other Regions, would necessitate complete cessation of subscribers' installation work throughout Scotland.

Wales and Border Counties

LOCATION OF ARMOURED CABLES

Anticipated difficulties in trench excavating on a new duct track between Carmarthen and Haverfordwest due to the presence, over some 14½ miles of the route, of two armoured cables have been largely overcome by the use of two Testers SA 9077 and Search Coils No. 1.

The major trouble was the Carmarthen-Milford Haven No. 1 MU cable which was laid, loaded and balanced over-ground in 1933 to restore communications to West Wales following a severe breakdown in the overhead route through storm. The cable was later buried and slack absorbed in large bights which frequently sweep back into the hedgerow. Road widenings, resurfacing and bridge reconstruction have added their quota of confusion and the cable is now at depths varying from 18 in. to 8 ft.

The method of location adopted was to connect the oscillator, powered by a portable 12V battery, to the lead sheath and to an earth spike approximately 6 in. from the cable.

The course of the cable was determined to within 1.3 in. (the diameter of the cable) at 800 yds. and to within 4 in. at 1,720 yds. The depth shown on the search coil was absolutely accurate at 520 yds. As it was considered inadvisable to mark the track too far ahead of excavations no locations at more than 520 yds. were carried out.

An interesting feature of the location tests was a characteristic "null point spread" of approximately 6 in. at certain spots. This was proved due to a contact between the cable being traced and either the second armoured cable or service pipes. When this condition was met, the problem was solved by opening up and reconnecting the oscillator beyond the contact. Locations then proceeded normally.

As a result of depth and course indications given by Departmental staff, contractors have been able to use mechanical excavators set at a depth just above the cables and thus speed urgent duct laying without endangering P.O. plant.

L. F. P. M.

TELECOMMUNICATION FACILITIES PROVIDED AT OPENING OF THE CLAERWEN DAM

The Claerwen Dam, which was opened by Her Majesty the Queen on 23rd October, 1952, serves as an additional reservoir for the main water supply to Birmingham and is situated on the border of Radnorshire and Breconshire, approximately 23 miles south-east of Aberystwyth in the lonely mountainous country of Central Wales. It is located in Rhayader exchange area, served by a small C.B.S.2 exchange in Radnorshire, the dam being approximately seven route miles from the exchange. There is no telephone development at all in this direction, the only lines going up the valley being temporary circuits for the building contractor.

Great publicity was given to the opening and heavy demands were made for picture calls, press, etc. As it was quite uneconomical to provide additional circuits to the dam for this event—the existing temporary circuits had been taken over by the police for control purposes—it was decided to dispose of the traffic at Rhayader by the provision of special circuits to Newtown automanual group centre (27 miles away) and to Llandrindod Wells (9 miles away). The additional circuits were provided by utilising two systems of ex-Army (1 + 4) Mk. II carrier equipment, thus giving additional trunk subscriber circuits to the group centres for rapid disposal of press material. The pictures were mainly taken by road to Llandrindod Wells or Aberystwyth and transmitted from those centres in the normal manner.

Only the existing circuit was available between Rhayader and Newtown, consisting of a 150-lb. 2-wire overhead circuit with a frequency response between 4.8 db. at 3.5 kc/s and 15.6 db. at 29 kc/s. This circuit was equalised to a slope of 1.6 db. utilising Zobel-type equalisers. The 1 + 4 carrier system employed, which is fairly familiar to Post Office engineers, provides four speech channels, in addition to the existing physical circuit and may be used on a 2- or 4-wire basis. For 2-wire working, one direction of transmission is group modulated at 35 kc/s and the equipment will operate with a line attenuation of approximately 40 db. at 32 kc/s, which represents about 100 miles of 70 lb. C.C. Signalling over the carrier channels is provided by 500/20 ringers, the signalling supplies being a 500-cycle oscillator and vibrator. The power supply requirements are 100V/250V A.C. or a 12V battery to operate the vibrator.

For the Rhayader-Newtown system the equipment was operated on a 2-wire basis using the 35 kc/s group modulator. To reduce cross talk from the Newton-Llandrindod Wells 1 + 3 overhead carrier, which occupied the same route, the

"A" station sending the high frequencies was located at Newtown.

Four generator signalling local battery telephones were installed at Rhayader on the Newtown carrier system to provide trunk subscriber circuits. These were lined up to 3 db., and proved very satisfactory for the clearance of press reports.

A second 1 + 4 overhead carrier system was installed between Rhayader and Llandrindod Wells, utilising the Rhayader-Llandrindod Wells portion of a Llandrindod Wells-Newtown junction, which was also utilised for the Rhayader-Newtown carrier referred to above. In this case equalisation was not necessary owing to the comparatively short distance, the frequency/loss slope being corrected at the individual channel amplifiers. The circuits were again terminated at Rhayader on generator signalling local battery telephones and used as Llandrindod Wells trunk subscribers.

All the equipment was mains operated, a D.C./A.C. converter being used at Llandrindod Wells as the supply there is at present D.C.

The utilisation of this army carrier equipment ensured that the normal junction facilities at Rhayader were available to deal with their appropriate traffic, without the long duration, long-distance calls for the "special event" monopolising them. In this manner an isolated and remote exchange was able to clear an unusual amount of heavy long-distance traffic to the satisfaction of both the users and the Post Office. G. J. A.

MOGFORD'S MANHOLE, NEATH

Mention of the name of Mogford's manhole has for many years been enough to make any Swansea jointer shudder. Situated on the main A.48 road, below flood tide level, cable repairs and maintenance works were always tidal operations. Worse was the ingress of sewage matter, the persistent smell of which was enough to give queasy feelings to all but the strongest stomachs. Very extensive investigations were carried out at various times, following cable faults, to trace the source of the sewage; even the use of coloured indicators in the adjacent drainage systems was tried, but with no conclusive results. The brickwork manhole was rebuilt in reinforced concrete, but again the troubles were not prevented.

It was finally decided to abandon the manhole, and to do this the existing tracks were intercepted on both sides by building two JRF 9 joint boxes and a length of 174 yds. of four 4-in. steel pipes laid at shallow depth across the old manhole.

A trench 120 yd. long having been opened, the steel pipes were laid out on trestles alongside, and welded by means of portable welding generators. The joints were wrapped and

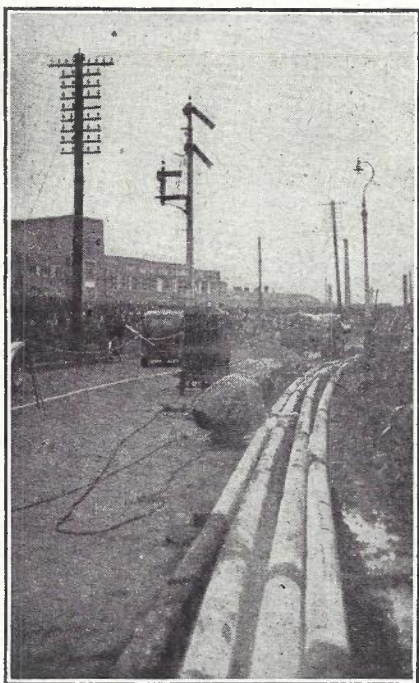

THE DIVERSION IN PROGRESS.

painted with bituminous compound and in 2 x 2 formation the pipes were lowered into the trench. It is interesting, that by laying in long lengths, the only set necessary was to avoid a water valve chamber. The pipes took up the general curve of the trench very well.

The cables have now been replaced in the new pipe line, the old ones recovered and the old duct and manhole filled in and abandoned. At long last the name Mogford's is expunged from the records, but it will not be forgotten by the jointers who have had to work there.

W. L. J.

Midland Region

UNUSUAL STRESS ON AN AERIAL CABLE

During a fierce gale which was experienced in the Stoke-on-Trent area on 17th December, 1952, a large elm tree was blown down across a wire-suspension aerial cable route in the centre of a span 60 yds. long. The tree, in falling, grazed others nearby, thus reducing its impact on the cable, and instead of breaking the cable, as might have been expected, forced it down a distance of some 17 ft. The 7/14 steel suspension wire and cable, erected in 1935, then rested on the hedgebank, which was 2 ft. higher than road level.

From the taut condition of the suspension wire and cable in adjacent spans, it was evident that the wire had pulled through the pole clamps on either side of the affected span. Examination of the cable in this position did not reveal any signs of external damage and tests of the subscribers' circuits proved them to be free of faults.

When the fallen tree was removed, the pronounced dip in the affected span disappeared, and a certain amount of slack became noticeable in adjacent spans. It was then decided to loosen all pole clamps between the termination points, pull the suspension wire through, and to reterminate at one end. When this was done, it was found that there was 1 yd. of slack in the cable, which was taken up by forming it in a loop at the termination pole. After renewal of a number of the marline ties at the poles, the cable appeared to be none the worse for the stress to which it had been subjected.

H. T.

TEMPORARY MUSIC CIRCUITS FOR PRIVATE RENTER

The completion of two music circuits from Wolverhampton to Stafford for a wire broadcasting company had been delayed for some months awaiting the provision of music amplifiers at Bloxwich, and shortly before Christmas the renter intimated that he had promised his customers service for Christmas, and asked if anything could be done to provide temporary service.

The circuits were due to be routed Wolverhampton-Birmingham-Bloxwich-Stafford on 20-lb. cable, and it was decided to try to set up the circuits without the Bloxwich amplifiers and equalisers, even though this meant the BM-SPA section would be nearly 30 miles long.

Equalisers were fitted at Birmingham to give a flat response, and a pre-equaliser added, giving about 10 db. lift to the high frequencies. The output from Birmingham was set to give 0 db. output at low frequencies, rising slowly to + 10 db. at high frequencies.

By this expedient, the high frequency level at Stafford was raised just enough to enable a reasonably flat response to be obtained at a level within the gain range of the music amplifiers. When the Bloxwich amplifiers are installed, it will only be necessary to cut out the pre-equaliser at Birmingham and reline the Birmingham-Bloxwich-Stafford sections.

The overall response of the circuits was flat within ± 1.5 db. and the noise level and crosstalk surprisingly good considering the difficult circuit. The renter was satisfied.

J. H. S.

AN UNUSUAL OBSTRUCTION IN A S.A.D. TRACK AT HOLMES CHAPEL

During rodding operations in a S.A.D. track in the above area, a stoppage occurred in a length of 200 yds. at a point about 7 yd. from a split coupling where the rodding commenced. The ducts were No. 12 S.A.D., laid in 1929, in carriageway and grass verge at a depth of cover varying from 2 ft. to 2 ft. 6 in.

The soil at this particular place was of a sandy nature, fairly dry, and the road in which the track was laid had been rebuilt

a few years previously, and sloped gently downhill with a slight curve. As this track carried only one 100/6½ pair cable and consequently should have had ample room for development, it was at first thought that the stoppage was caused by external damage to the track. Exposing the track, however, revealed nothing, and when the actual duct was broken down, it was found that "Jelly Petroleum" solidly packed in two ducts was the only reason for the obstruction.



THE PETROLEUM JELLY OBSTRUCTION.

The photograph shows how tightly the jelly was packed in the ducts with the original cable buried in about the centre. The overall length of the mass is about 63 in. and has remained quite solid after two or three weeks' storage in a heated garage. The only apparent cause is badly applied jelly when drawing in the cable, and some obstruction that caused the cable to be stripped of its jelly at the point of stoppage. H. T.

London Telecommunications Region

M.C.A. NATIONAL SIGNALS CENTRE, CROYDON AIRPORT

A new Civil Aviation Communication Centre was brought into service by the Ministry of Civil Aviation at Croydon Airport at midnight, 12th January, and opened officially by Mr. J. Profumo, Parliamentary Secretary for Civil Aviation, on 19th February, 1953. This centre replaces the one at London Airport and is designed to handle, with the minimum of delay, operational messages between airport, air traffic control centres, and operating companies. The centre is housed in one of the Croydon Airport buildings which has been entirely reconstructed internally. Its layout has been designed to utilise the latest automatic and machine telegraph equipment, and to reduce handling time, an important factor owing to the greatly increased speeds of the latest type of aircraft now coming into service. At present, the centre handles about 1,000 messages during the peak hour, over some 30 circuits. Ultimately it will deal with 3,000 transactions over approximately 60 circuits over the same period.

A new type of console, to house printing re-perforators and Transmitters Auto No. 2A, was designed and made by the M.C.A. Each console contains three instruments, one above the other, which are mounted on sliding shelves to facilitate tape changing and general maintenance. Close attention to silencing was given during the construction with marked success.

Thirty-eight Printing Re-perforators No. 2 handle the incoming traffic, with a further 24 in service in the tape production pool. This pool is used to produce copies of the original tapes when required. Forty-six Transmitters Auto No. 2A are installed to cope with outgoing traffic and 41 Teleprinters 7B are used for monitoring and miscellaneous duties. Eighteen Number Transmitters are available for use on circuits where sequence numbering is desired.

Two 18-channel M.C.V.F. and two 8-channel M.C.V.F. systems provide channels to all parts of Europe and the principal radio links are via Birdlip Radio Station.

Two 8-kW motor generators supply power for the machine side, while Rectifiers 58A cater for H.T. and L.T. supplies in conjunction with suitable batteries.

An interesting feature is the pneumatic docket tape system which employs transparent plastic tubes. A length of perforated tape is clipped to a felt plug about the size of a small egg which draws it through the tube at a very high speed, and gives rise to its nickname of "The Flying Tadpole."

Ample workshop accommodation was provided by the M.C.A. and full advantage has been taken of this to provide a well-equipped shop to handle a maintenance load mainly on telegraph machines.

The change-over was carried out piecemeal to a time schedule. It was spread over 8 hours, each distant station

being advised to cease transmission until called by Croydon. The whole operation was carried out with commendable smoothness and a minimum of interference with traffic.

A. J. P.

FLOOD DAMAGE IN SOUTH-EAST AREA

On the morning of 1st February the River Thames had flooded a section of the marshes and low-lying ground from just east of Woolwich to Greenhithe and penetrated inland to a depth of over a mile in places. From a telephone point of view it was remarkable that only about two hundred lines were actually testing faulty and a number of cables remained under water for a fortnight without failure.

Immediate concern was to provide temporary service at some point to handle messages for people and firms who were evacuated from the area. In co-operation with the local council a message bureau was opened at the A.R.P. control at Erith Council offices and the Erith auto-manual switchboard at Woolwich diverted all enquiry traffic to this point.

External gangs set to work by boat and lorry to run essential lines out over the flood water to pumping stations and key points. Farther down river at Dartford the rush of water swept away the road to Littlebrook power station and with it the track carrying cable circuits linking the station with the control centres of the grid system. An interruption cable was laid by boat direct in the flood water and all the 20 circuits quickly restored.

A repair centre was set up at Dartford to handle the floor-type switchboards and P.A.B.X. equipment which were brought out of the flooded factories. Most equipment had been in 2 to 3 ft. of water and once the river mud and slime had been removed it quickly responded to drying-out treatment and was ready for reinstatement as soon as the subscribers wished.

Letters of appreciation for the work done by the engineering staff have been received from the British Electricity Authority, Callenders Cables Ltd., and other subscribers. W. H. O.

Home Counties Region

BATH ROAD, TWYFORD—CANBERRA BOMBER CRASH

On 27th January at approximately 10.30 a.m. a jet bomber crashed on the Bath Road near Twyford, forming a large crater (about 20 ft. deep and 50 ft. across), and completely smashing the main underground route. This consisted of a 3 W.M.D. containing the London-Bristol MU (308/20), the London-Reading No. 1 MU (54/70 + 54/40), two CJ cables and a subscribers' cable; also a C.I. pipe containing the London-Penzance cable (4pr/150 + 28pr/100 and 7W/40 + 44W/70 + 22W/200 single screened).

Debris was scattered over a wide area and to allow the R.A.F. to carry out salvage operations it was necessary to make rather a wide sweep with interruption cables, a length of approximately 160 yds. being required for each cable.

Fortunately, sufficient interruption cable of types suitable for the initial repairs was available within the Area, and by

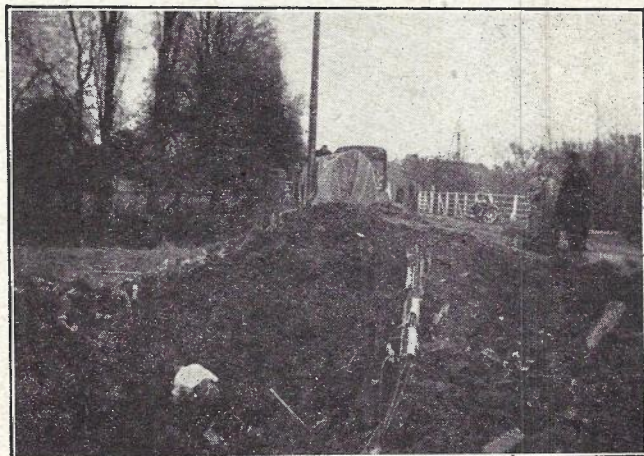

CABLE REPAIRS IN PROGRESS.

arranging for a day and night shift of jointing staff it was possible to restore service on the first C.J. cable by 8 p.m. on the day of the crash. By 8 a.m. on 28th the majority of the London-Bristol circuits had been restored, some of the London-Penzance, the second C.J. and the local cable, and by the evening of that day temporary restoration was complete.

Permanent repairs involving provision of some 18 yd. of new 3 W.M.D. with a 4-in. S.A.D. to replace the C.I. pipe, have since been carried out. Unidiameter joints were made *in situ* at the points where the track was broken into for connection of interruption cables, thus effecting a saving in new cable as against renewal of complete lengths and, by permitting the track to be restored using split ducts, avoiding the extra expense of providing new jointboxes or manholes. E. J. M.

FLOOD DAMAGE

The effect of the recent floods on Post Office plant was not only very slight in comparison with the great loss of life and widespread damage, but it was generally smaller than that from major snow storms to which we are from time to time accustomed. The five east coast Areas affected, Cambridge, Norwich, Colchester, Southend and Canterbury, all managed within their own resources of staff and with relatively few extra stores, at least in the early stages.

About 7,500 lines were out of service, the majority due to cable faults. Flooded exchanges and overhead plant each accounted for some 1,600 lines. Overhead plant seemed to withstand the gale surprisingly well, but appreciable damage occurred in the Norwich Area.

Cable faults were most severe at King's Lynn, Lowestoft, Felixstowe, Ipswich, Canvey, Chatham (Strood) and Whitstable. Half the subscribers were affected at Whitstable and leakage of petrol from a 500-gal. tank which became damaged was one of the difficulties experienced in nearby manholes; fumes were cleared by vacuum cleaners. In addition to the spate of slight cracks which inevitably come to light during floods, especially on the smaller cables, some faults were due to subsidence and breaches in banks along which cables were routed. At Southwold 1,000 yd. of 100-pair cable was manhandled along a narrow ridge between two flooded areas to restore service temporarily to the isolated village of Walberswick.

Sheerness non-director exchange (680 lines) was flooded to a depth of 1 ft. and was out of action for five days. The whole Isle of Sheppey was cut off from the mainland by road and rail, but the junction cable from Sheerness to Chatham held, and service was quickly restored over this cable to ten emergency lines and kiosks. The water did not quite rise above the lead sheath on the terminating cables and similarly stopped just below the main auto equipment and motor generators. The power switches and tone transformers were affected, however, and renewal of the latter was necessary. Emergency charging plant, in the absence of the mains supply, and a pump, were shipped to Sheerness, and after barricading the lower part of the doorways with wood and compound, it was possible to pump out water from the exchange to the outside "lake" surrounding the exchange. Within the next day or two all subscribers were restored except for about 120, out of service due to cable faults and flooded premises. The equipment is functioning well and seems none the worse for its experience.

The five-position C.B.S. 2 exchange at Canvey, with 612 subscribers, was flooded to a depth of about 15 in., though the water quickly subsided to just below floor level. In this case the terminating cables were soaked and water had penetrated about as far as the joints with the paper-core cables. The latter, consisting of four 200-pair and a 74-pair, were re-terminated on cabinet assemblies fixed to the wall of an adjacent room. These assemblies, complete with tails, are quickly connected by the simple paper-core joint and make an excellent temporary M.D.F. A 3 + 9 P.B.X. was used for the first day or two for emergency services and then replaced by a 10 + 50, mounted on a platform and cabled to the temporary M.D.F.; 10 junctions and 30 emergency subscribers were connected to the latter P.B.X.

Damage to the main switchboards was limited to the repeating coils, capacitors and cords. New repeating coils and capacitors were mounted on the upper part of the wall behind the boards and cabled to the existing forms, joints being made within the cable forms rather than cabling right back

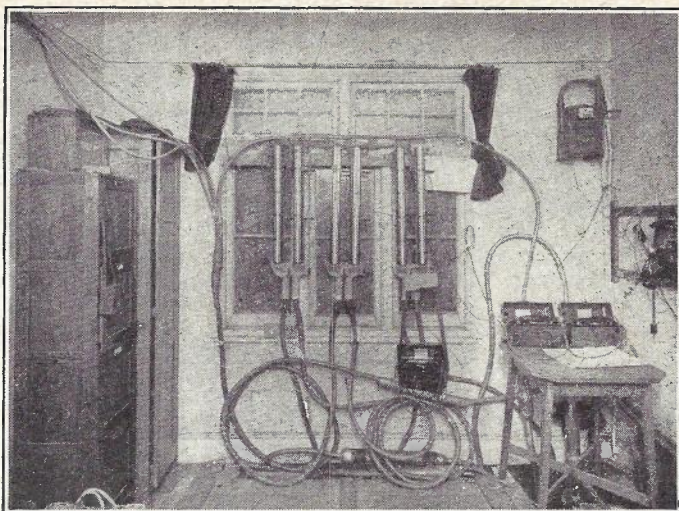

TEMPORARY CABLE TERMINATIONS AT CANVEY EXCHANGE.

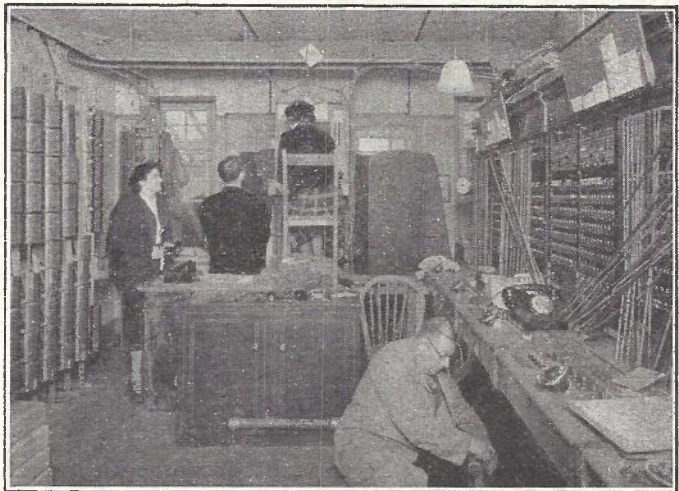

P.B.X. 10 + 50 MOUNTED ON PLATFORM IN CANVEY EXCHANGE.

to the keyshelf. The lowest I.D.F. connection strips were renewed and the ends of the wiring to these washed clear of salt water, dried and rewaxed. The cords were renewed and rewiring was required to the C.T.I. and the ringer but the latter, together with the other power plant, escaped damage. New terminating cables were provided to the existing M.D.F., the lead sheath extending 3 ft. above floor level. The forming of these cables was particularly awkward since only 20 lb. cable was available and the wires had to be worked behind the existing jumpers and fuse mountings. The original switchboard was brought back into service after the first week, section by section as required, and the junctions and emergency lines were routed via a small temporary tie cable, terminated on connection strips, between the temporary and normal M.D.F.s. The external cables were then diverted back to the normal M.D.F. and all lines which tested clear restored to service, normally without any re-jumping. About a third of the lines thus restored tested "no reply," so the returning subscribers should have a pleasant reaction to find the telephone working; the condition of the wiring and instruments will, however, be checked in due course.

During the second week 400 lines were restored, cable faults and premises still flooded being the limiting factor. In some cases wet joints or sections were by-passed by temporary "loops" above water level. In one case a joint was being re-made but a borrowed pump lost its head of water and could not be reprimed before the water rose rapidly above the joint. New telephones, change of cords and/or rewiring will probably be required for about 100 subscribers.

In general the Post Office work has been ahead of the requirements of returning subscribers, and, with the modifications now made at the exchange, it should continue to function to

a large extent even if it should again become flooded. The operators will ensure at the outset that the cords are pulled clear of water.

Jaywick U.A.X. 13, although in a flood-type building, was submerged to a depth of 3 ft. 6 in. Much marsh grass and hay had found its way in through the letter box as did an adder, found coiled on the tool cabinet which was afloat! 13 subscribers and 3 kiosks outside the flood area were quickly diverted over the junction cable to Clacton and as soon as access to the cables could be obtained a mobile U.A.X. 12 was brought into service. It was sited on the junction and subscribers cable route $\frac{3}{4}$ mile nearer Clacton and D.P.s between the old and new exchanges were diverted to the latter. Service has now been given to 75 out of the original 112 subscribers. Some will not require restoration and the U.A.X. 12 may suffice until it is decided whether to renew the U.A.X. 13 equipment in the present building or rebuild on a safer site and nearer the centre based on the present trend of development.

St. Germans U.A.X. 13 (near King's Lynn) was flooded to a depth of 1 ft. 9 in. when the River Ouse, about 100 yds. away, burst its bank. The force of the water swept away most of the fence and the footpath, and also some lightly constructed buildings nearby, but the level quickly subsided and this particular breach was repaired on the following day.

The terminating cables were soaked but were dried out temporarily after cutting back about a foot of the lead sheath; similarly the lowest row of L and K relays were affected but functioned after being dried. Some of the route discriminating and multi-metering equipment needed renewing, but the exchange was in working condition within a day. Cable faults near the exchange, however, prevented restoration of service until the end of the second day.

The number of lines out of order in the Region was reduced to 2,000 by the end of the first week and 400 after the second week. It is estimated that not more than 1,000 telephones will require changing and/or rewiring. About 35 P.B.X.s were damaged and also a teleprinter. Many kiosks were affected, several being overturned, and the renewal of coin box mechanisms is making unfortunate inroads into an item of stores already in short supply. No cabinets were under water and most pillars withstood the test; where failures did occur it was generally due to water entering the cable tails. Many additional emergency lines, including teleprinter circuits, were provided as an urgent measure, especially at strategic points for the civil, military and catchment authorities.

It will be appreciated that the work has given plenty of scope for local initiative and ingenuity and has involved long hours under difficult conditions. The staff have responded with that extra effort which is always shown at times of emergency.

R. O. B.

RE-ERECTION OF HEAVY AERIAL CABLE

Resulting from the collision of a motor vehicle with a telegraph pole during November, 1952, the Bicester-Northampton 4Sc/40+290/20 PCQL aerial cable became detached from its suspension rings for a distance of approximately 1,100 yds., and fell to the ground. Once a few yards of the cable is jarred from the rings the weight of this unsuspected length, if a very large cable is involved, drags off the rings on either side in rapid succession ("unzipping"), until arrested by a loading pot, tree branch, high hedge, etc. For most of the distance the cable fell on the grass verge, but at one acute bend in the road it fell across the roadway and before it could be moved a considerable amount of traffic passed over it.

The lead sheath was damaged in a number of places through striking projections on the poles, i.e. bolts, pole numbers, etc., as it fell, but despite inclement weather and ice-bound roads, patch wiping repairs were speedily effected and no interruption to service was caused. The diameter of the cable (2.03 in.), and its weight (15.15 cwt. per 100 yds.), together with the several angle poles along the route, presented a problem on the method to be employed in re-erection, but after consideration of all facts, including the scarcity of lashing wire, it was decided to use normal cable rings.

The method employed consisted of a simple device using two sets of rollers, one set to take the main weight of the cable, and the other to bring it to a position close to the suspension wire. An additional lifting device consisting of

single and double blocks was used to assist in raising the cable and also to facilitate the movement of the rollers.

The lifting device comprises:— (a) two cable pulleys directly coupled together, connected by a 10-ft. length of 3-in. rope to (b), a snatch block (travelling on the suspension wire) with a coupling device to another cable pulley. The coupling consists of a stay swivel which enables a uniform distance of approximately 3 ft. to be maintained between block and pulley. Single 2-in. ropes connect the latter to a winch, fitted temporarily in the body of a vehicle 40-60 yds. away.

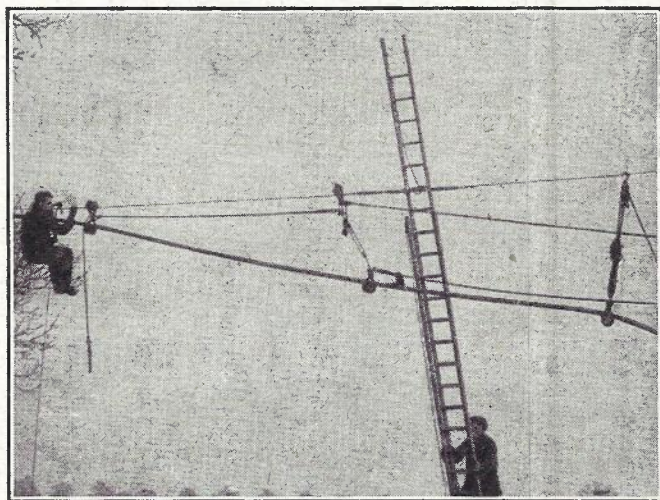

LIFTING DEVICE EMPLOYED IN RE-ERECTION OF AERIAL CABLE.

The operation of the winch moved the two sets of rollers forward, lifting the cable to a position near to the suspension wire. A workman, in a ringing chair, followed behind the end rollers at a distance of approximately 4 to 6 feet, this being the optimum distance where the cable rings could be fitted without undue strain.

The single and double block lifting tackle was necessary to assist in the free movement of the rollers and also to take the weight of the cable when the rollers were being dismantled and moved over obstructions, i.e. joints in the suspension wire, cable joints, and when passing each pole.

Seven men were employed, but progress was limited to the speed at which the rings could be fitted. Delays occurred at every obstruction on suspension wire and cable and also at each pole, where the short distance between the suspension wire and the top of the poles prevented effective use of blocks and tackle. A small amount of slack cable which accumulated at the end of the operation was fed back to nearby angle poles by reverse action of one set of rollers.

Pressure was applied to the cable immediately after the initial accident and was maintained throughout the interim and the operation period. It was beneficial in revealing sheath damage at several points, prior to re-erection, which otherwise may not have been detected until faults developed later.

Brackets No. 25 have been fitted at all angle poles and to every fourth pole along the route in an endeavour to restrict any future fall. There have been several similar "unzippings" in other parts of the Region and it has now been decided to fit Brackets No. 25 as above on all ringed cables exceeding 8 cwt. per 100 yds.

F. S. F., C. D. S. R.

North-Eastern Region

RADIO CONTROL AIDS ENGINEERS IN LINCOLNSHIRE FLOOD DISASTER

On the fateful night of 31st January, 1953, the Maintenance Officer at Alford was asked to investigate uncertain behaviour of Sutton-on-Sea U.A.X. 13 junctions and heard rumours that there was flooding in the High Street. At the approaches to Sutton deepening water barred the possibility of further progress in his Morris Minor and, returning it to dry ground, he proceeded towards the exchange on foot, wading waist-high in the icy waters before abandoning the attempt. Returning to the van he found the seats awash and the engine useless.



RADIO CONTROL VAN FITTED WITH V.H.F. TRANSCEIVER.

After taking temporary refuge in a signal box he struggled through two miles of water and reached Alford, some six miles inland, five hours later. Thus began the dreadful tale of devastation to telephone plant in the Lincolnshire Telephone Area. Sutton-on-Sea exchange, built 4 ft. above the general road level, was nevertheless flooded to a depth of 3 ft. 5 in. above floor level. The effect of sea water on selectors and batteries may well be imagined. For days the only approach to the exchange was by rowing boat.

As soon as conditions permitted it was proposed to install a M.A.X. 13 to restore service to Sutton-on-Sea subscribers. The earliest date for this was 21st March, following the high tides of the March Equinox when the sea defences were expected to be severely tested.

At Mablethorpe, four miles to the north, the U.A.X. 14 had a narrow escape when water flooded the building to a depth of 8 in., barely missing the unprotected silk and wool forms at the base of the M.D.F. The electricity supply failed, but by disconnecting the faulty lines, the officer in charge was able to conserve the battery until an emergency generator was made available. At least half the subscribers' lines were out of order, due mainly to their instruments having suffered immersion.

Several serious breaches had occurred in the sea defences, the largest of which, known as the Acre Gap, occurred just south of Sutton-on-Sea. An emergency control set up at Louth provided essential telephones in the stricken areas. Initially the Police and River Board claimed attention and these were soon followed by requests from the engineering contractors responsible for rebuilding the defences. On the day following the flooding seven lines to police and evacuation points were provided and this number rapidly grew so that 80 lines were provided, often under most arduous conditions, during the first two weeks of the emergency.

Cables which had served Sutton-on-Sea were hoisted out of the water-logged earth on the outskirts of the town and interruption cables enabled essential subscribers in the flooded area to be connected to Louth exchange via long-line equipment.

Forty additional junctions were added to the 110 existing at exchanges in the locality, at Alford U.A.X. 14 the number of outgoing junctions being increased from five to 13. The Humber radio station, which provides short-range telephone service with coastal ships, lies between Sutton and Mablethorpe and this also was flooded and useless. It was replaced by a mobile station which was erected at Kenwick Hall, near Louth.

Perhaps the most revolutionary innovation from the Department's viewpoint was the introduction of radio-controlled vans. Two fixed and two mobile stations were provided in response to an appeal to the Engineer-in-Chief. The mobile stations were mounted in 8-cwt. vans as shown in the illustra-



SUBSCRIBER'S INSTRUMENT AFTER PENETRATION BY SAND.

tion, whilst fixed transmitters were sited at Withern and Mablethorpe, the former being operated by remote control from Louth. By this means constant two-way contact with key officers at the scene of the disaster was effectively maintained and many valuable hours were saved. The arrangement met with unanimous approval and we look forward to the time in the not too distant future when we foresee that such a system will become an integral part of the control of engineering parties working in the field.

The Lincolnshire coast is renowned for extensive beaches of fine sand, but even so the amount carried in suspension by the flood waters was almost unbelievable. Where broken windows or open doors allowed unrestricted access to buildings, the depth of residual sand almost equalled that of the water. The second illustration shows the penetration of sand to the innermost recesses of an instrument retrieved from such a situation.

J. W.

COMBINATION OF OSSETT AND HORBURY EXCHANGE AREAS

Ossett and Horbury manual exchanges are due for replacement around 1958, and as the exchanges are only one and a half miles radial distance apart, a cost study was undertaken to determine the most economical future layout under non-director automatic conditions.

The costs showed a substantial balance in favour of a single combined exchange to serve both areas. Major savings were achieved in respect of building costs. This part of the West Riding of Yorkshire is subject to mining subsidence and calls for expensive concrete raft construction to strengthen building foundations. Based on current costs for a similar type of exchange building now in course of erection in an adjacent area it was estimated that a single building to house the combined exchanges would be cheaper by £16,000 than two separate ones.

Of more particular interest is the decision only partially to combine the exchanges in the new building, a plan which is new so far as the North-Eastern Region is concerned.

With characteristic Yorkshire pride (and obstinacy) the two communities would not accept any loss of identity. Ossett claims fame in the cloth and woollen trade, whilst Horbury relies mainly on its engineering and mining prowess.

Under the approved scheme, therefore, both Ossett and Horbury will appear in the Directory, separate levels being reserved for each in the new exchange, and each still retaining the existing call charge rates.

R. T.

EXTENSION TO MIXED 5 AND 6 DIGIT WORKING IN LEEDS AUTOMATIC AREA

The realisation that the subscribers' development would shortly outgrow the present five-digit numbering scheme, coupled with the fact that exchanges in the Leeds linked numbering scheme were due for replacement, has resulted in the design of a numbering scheme, on a mixed five and six

digit basis, that would permit growth (once the scheme had been implemented) to 150,000 multiple, without any future change of subscribers' numbers. The present scheme would allow of a maximum of 60,000 multiple.

The existing D.S.R. exchanges are to be replaced by group selector exchanges, with direct trunking between all exchanges in the linked numbering scheme. In the proposed scheme the larger exchanges are to remain five digit, and the remainder will become six digit.

It can be seen from the trunking diagram of the present scheme that levels 61 to 64 are occupied by Roundhay, and 65 and 66 are proper to Moortown, which is now working hypothetically at Roundhay exchange, and it was decided that level 6

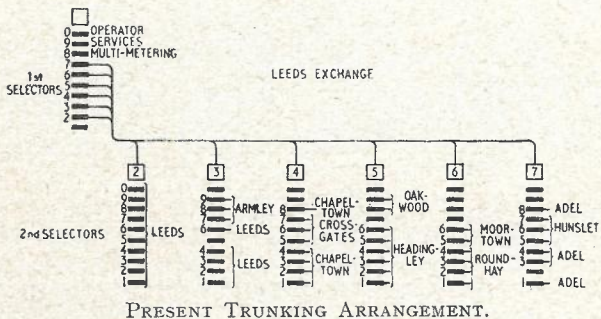

PRESENT TRUNKING ARRANGEMENT.

would be a suitable choice for the level taking six-digit exchanges. Additional racks of selectors were installed at Roundhay by the contractors and on the 28th January, 1953, the changeover of Moortown subscribers was effected. Subscribers in the range 65,000 to 66,999 became 685,000 to 686,999 by the interposition of the second digit "8." A verbal announcing equipment has been connected to the levels vacated, to announce to the subscribers that "The number you are calling has been changed; please consult the new directory." After a period of interception, the levels 65 and 66 will be spare and in July of this year the present Roundhay subscribers' numbers in the range 61,000 to 64,999 will be converted to six digits by prefixing the digit "6" to their numbers which will become 661,000 to 664,999. This will reduce the levels in use to 66 and 68; 61 to 65, 67 and 69 will then become available

for the changeover of other exchanges by the simple method of prefixing 6 to the existing number. The transfer to the new levels will take place over the next few years.

From the trunking diagram showing the proposed mixed five and six digit scheme it can be seen that the groups of circuits to each satellite exchange are reduced to one in each case. The trunking diagram at each exchange will be similar to that of the main exchange in respect of the subscriber-to-subscriber dialling.

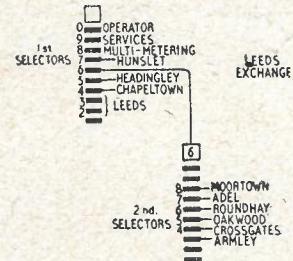

PROPOSED TRUNKING ARRANGEMENT.

and it is considered that the introduction of direct dialling between satellite exchanges, and consequent cessation of the tandem link through the main exchange, will improve maintenance.

F. E. P.

South-Western Region

PITCH-PINE SQUARE-SECTION POLE

Although shortly to be recovered after standing for nearly 70 years, the pitch-pine square pole at Alphington, three miles from the centre of Exeter, provides an interesting link with past practice.

Evidence of its original purpose as the terminal pole for the old gutta-percha telegraph cable still exists in the porcelain "lead in" insulators situated at the top of the pole. Through these insulators the "tails" to the overhead line wires were fed from the cable termination.

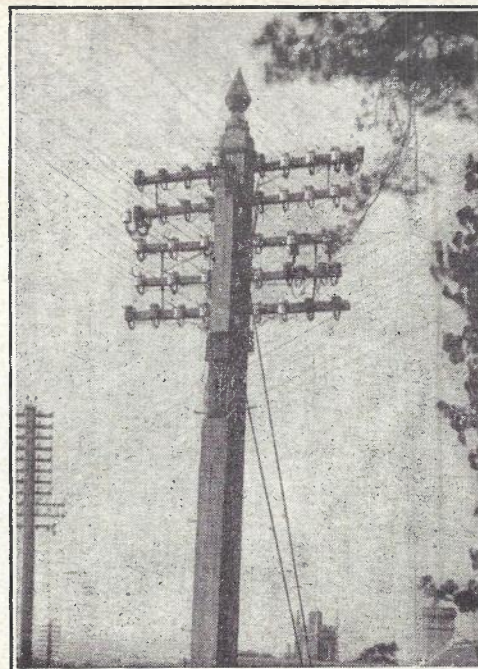

PITCH-PINE SQUARE-SECTION POLE.

Unfortunately there are no records showing when the pole was first erected and the original date stamp (if one ever existed) is no longer there, but reliable information makes it almost certain that the pole was erected in about 1884. This evidence is supported by the fact that the route was constructed to carry telegraph circuits provided under the "six-penny telegram" scheme. At that time the pole carried about half a dozen No. 8 galvanised-iron single-wire circuits. To-day, it carries nine subscribers' lines and two junctions together with a number of spare wires.

These pitch-pine poles were used frequently for the terminal poles of telegraph lines, but to-day there are probably few left. The timber was not treated with creosote, but the butt was charred and coated with tar before erection. The portion above ground level was painted.

It is uncertain whether this particular pole was originally treated with copper sulphate, but its life certainly rivals that of many creosoted poles. There is evidence of slight decay at ground level, but elsewhere the timber appears sound. Although its age and condition cannot rival that of the 1870 pole standing on the Warwick-Stratford-on-Avon road, it provides another interesting example of the type of poles used for overhead line construction.

P. L. R. W.

CABLING IN LARGE PEBBLES

It was recently necessary to lay a 4,000-yd. length of 122/10 tape armoured cable at a depth of 2 ft. in a beach made up of pebbles varying in diameter from 1/2 in. to 2 in.

The Electricity Authority already had a cable in the beach at a depth of approximately 2 ft. 6 in. and it is reported that the laying of this had taken some 40 weeks in a trench over 5 ft. in width. The width was necessary because the pebbles rolled back into the excavation.

Neither time nor cost would permit of methods such as this, and after consideration the very feature which caused the Electricity Authority to have to build such a wide trench, viz. the roundness of the pebbles, was that which permitted a cheap and quick method to be used. The cable was mole-drained using an International TD9 tractor, a standard mole-drainer and a two-wheeled cable-drum carrier all in tandem. The 4,000 yards was laid in three and a half days.

The boxes for jointing and loading coils were excavated for by placing a framework on the stones and digging from inside to gradually allow the weighted framework to sink. The box was then built in the excavation.

W. J. P.

Associate Section Notes

Bedford Centre

This Centre was reopened in June, 1951, after a lapse of three years and, although a very interesting and instructive programme has been held since that date, this is believed to be the first post-war report to appear in the JOURNAL.

During the first years of our renewed life the programme has consisted of visits to local firms and authorities ranging from Vauxhall Motors, Luton, where we saw cars built up from steel pressings to finally drive off the assembly line ready for the road, to the local waterworks and pumping station, where many members were fascinated by the long-lasting echo in a new underground reservoir which was empty at the time of our visit. These visits were interspersed with several interesting talks on subjects as diverse as "The Present System of Appraisal and Promotion," by Colonel C. E. Calveley, O.B.E., B.Sc., M.I.E.E., President of the Associate Section, and "Gas Generating Plant," given by Mr. R. Bottomley, of the Eastern Gas Board.

The Centre is planning to carry out an equally interesting programme in the coming year and it is hoped that we shall continue to receive the support of all our members. A. D. T.

Birmingham Centre

It is pleasing to be able to report that the membership of this Centre is still growing, the present figure of 232 being an increase of 90 over the figure for last April. Attendance at meetings has also improved and all visits have proved so popular that it has not always been possible to include everyone wishing to join the parties. These notes will be published just prior to the Annual General Meeting and it is to be hoped that as many members as possible will attend, for it is at this meeting that the policy and programme are formulated for the next session.

The circulation of periodicals, run on similar lines to that of the Senior Section, has been so well supported by members that it may be necessary next session to purchase additional copies of some magazines owing to the number of people wishing to be included on the lists.

Since the last notes were written, talks on a variety of subjects have been well attended, the most popular being "Servicing Television Receivers," when 38 members and seven visitors were present at a most interesting and well-presented talk given by Mr. G. W. Jones (late of E.M.I. Sales & Service, Ltd.). The treasurer of this Centre, Mr. A. C. Rotherham, had an audience of 34 members and 10 visitors when he spoke most ably on a subject which has been much in the public mind, due to being featured recently by the press—the subject was "Interplanetary Travel." Mr. Rotherham, who is also Secretary of the Midland Branch of the British Interplanetary Society, provided members with a thoroughly enjoyable evening.

A talk by the deputy overseer of the composing room of a Birmingham evening newspaper was most instructive, whilst the visit to the printing works of that newspaper the following week served to demonstrate the efficiency and speed with which a newspaper is produced.

Other visits which have taken place recently have been to one of Birmingham's largest breweries, to a chemical plant of I.C.I., Ltd., at Oldbury, and to the Department of Archaeology and Local History of the City Museum, the party being conducted round this collection by Mr. Oswald, M.A., F.S.A., the keeper.

A talk on "Plastics," illustrated by an excellent coloured sound film, was given by the sales development manager of Bakelite, Ltd., Mr. W. E. Patman, who brought along innumerable samples and went to endless trouble to explain every point to a keenly interested audience. The most recent talk was one given by an assistant engineer of this Area, Mr. F. A. A. Pariser, who gave a very interesting discourse on "Cable Corrosion and Protection." K. G. S. A.

Bishop's Stortford Centre

The 1952/53 session opened on 17th September, with a film show given by Ovaltine, Ltd., followed by the Annual General Meeting, when the programme for the session was discussed

and approved. In October, a limited number of members visited the Murphy Radio works at Welwyn, and were shown the various stages involved in the production of both sound radio and television receivers. Methods of testing and fault localisation in television receivers concluded a very interesting visit. Owing to very bad weather the film show planned for December had to be cancelled at short notice.

The next meeting was held in January, when Mr. A. H. C. Knox (Regional Engineer) gave a very interesting talk on "Appraisal and Promotion." After the talk Mr. Knox answered various questions relating to his talk.

At the time of writing this report, an interesting and varied programme had been arranged for the remainder of the session, including visits to the Hertfordshire Police Headquarters at Hatfield, to the London offices of the *Daily Mail*, and to the Vauxhall motor factory at Luton. R. A. C.

Cambridge Centre

At the Annual General Meeting held in April, 1952, the following were elected as officers for the 1952/53 session:—

President, Mr. W. E. Dance, Telephone Manager; *Chairman*, Mr. L. A. Salmon; *Secretary*, Mr. J. P. Wearn; *Vice-Chairman*, Mr. B. S. Cranfield; *Treasurer*, Mr. K. H. Phillips. *Committee*, Messrs. H. P. Brooks, H. W. Haworth, J. K. Giles and G. V. Short. *Auditors*, Messrs. L. W. Pooley and N. Radford.

The winter programme commenced in September, when 26 members (selected by ballot) visited Messrs. Stewart & Lloyd's steelworks at Corby, Northants. This was followed in October with an illustrated lecture, "Trunk Mechanisation," by Mr. A. J. Thompson, E.-in-C.'s Office. In December a party visited the local gasworks. The new year commenced with a lecture—"Some Recent Developments in Switching Design"—by Mr. F. Gresswell, of Home Counties Region, and this was followed by a visit to the *Cambridge Daily News* printing works. The session concluded with a visit to the new Telephone Repeater Station, Trumpington, and the A.G.M. and Film Show. J. P. W.

Canterbury Centre

Since our last notes were published, the Annual General Meeting has been held. The new committee comprises:—

Chairman, V. Dungey; *Vice-Chairman*, L. J. Martin; *Secretary*, G. E. West; *Treasurer*, K. B. Chapman. *Committee*, B. Fletcher, C. Cox, H. Marsh.

Mr. Knox, Regional Liaison Officer, addressed the meeting, which was very well attended.

During the summer a party of members paid a visit to Chislet Colliery.

The 1952/53 session commenced in October, 1952, with a talk by Mr. Gerry entitled "Are Overhead Lines Worth While?"

In November a visit was made to the Dover Engineering Works to see how the Post Office Elkington-pattern manhole cover was manufactured. Later in the month Mr. C. W. A. Kent (Chief Traffic Superintendent) spoke on "The Function of the Traffic Division."

There was a visit to Canterbury Tannery in December, and the monthly talk was given by two members, Messrs. Leutchford and Ward. Their subject was "Youths-in-Training in National Service."

The speaker for January was Mr. E. C. Wilson. He provided amateur photographers with interesting information in his talk on "Cameras—How They Work and How to Work Them."

The remaining programme consisted of:—

February.—"Practical Aspects of Cable Fault Location," by Messrs. Payne and Bushnell.

March.—"Frequency Modulation," by W. Seymour.

We have an ambitious programme for the Annual General Meeting; details will be given as early as possible.

In brief: Canterbury Centre has a membership of 115. Meetings are generally well attended. A Radio Section has been formed at Thanet.

The change of title to Associate Section has been received with general satisfaction. Senior members' interest continues. G. E. W.

Chiltern Centre

Our Annual General Meeting was held on Thursday, 11th December, when Mr. H. Robinson was elected *Chairman*, Mr. F. Sherriff *Vice-Chairman*, and Mr. H. J. Trotman, *Secretary*.

Past and future programmes were discussed, and suggestions for activities in 1953 were noted by the Secretary; also the problem of attracting new members received attention.

Last session's programme included talks and discussions on "Post Office Finance," "Radar," "Coaxial Working," "Cycling" and a film show.

For the coming session we have "Costs and Statistics," by Mr. A. H. Knox, Regional Engineer; "Transmission," by Mr. D. H. Noble; "Amateur Radio," by Mr. K. E. Felton; "Some of our Problems," by Mr. R. C. Such, our Area Engineer; and a debate "Is Television Worth While?"

A "sausage-roll supper" concluded the Annual General Meeting, a convivial and worth-while event. H. J. T.

Darlington Centre

The half-way stage has now been reached in the Centre's programme and on reflection the committee feel highly satisfied with the reception of the fare served up at the meetings. A little propaganda by those members who come along should result in increased attendances.

A brief account of recent events is given below.

25th November, 1952.—A Darlington Centre member, Mr. G. Dale, gave an "Outline of Multi-metering in Non-Director Areas," which was followed with much interest and a good discussion.

6th January, 1953.—Mr. H. Hopkins, the Town Clerk of the County Borough of Darlington, was the guest speaker and he described all the aspects of "Local Government"—the history from its origin up to the present constitution of the mayor, aldermen and councillors, who are responsible for the administration—the work of the various departmental committees, and the effects of nationalisation of public services. This illustrative and informal talk was the prelude to a most lively and enjoyable discussion, which was commented upon very favourably by Mr. Hopkins.

3rd February, 1953.—"Income Tax—from the Underside," by Mr. E. J. L. Hochstrasser, also proved to be most interesting and informative; the speaker reviewed the work of his department from an unusual angle. In the discussion there was no lack of questions and these were ably dealt with to the evident satisfaction of all.

The non-technical talks intermixed in the programme have proved most interesting.

In the near future it is hoped to visit a cable ship, Patons & Baldwins, and Glaxo Laboratories. C. N. H.

Guildford Centre

The Guildford Centre can claim to have had successful autumn and winter sessions despite the fall in membership which followed the decision to raise the quarterly subscription to 2s. to find the money to pay for our 16-mm. ciné projector.

The projector is now paid for and has provided many enjoyable evenings. The membership figure is also now much improved and at the moment is 107, which is about 20 per cent. of the Area labour force.

The monthly film shows have been well attended by audiences of 30 to 40. The programme material has covered many aspects of engineering, industrial processes, travel and subjects of wide general interest. It may be a point of interest that 33,600 ft. of 16-mm. film is required to provide eight two-hour shows.

Factory visits continue to be popular and to provide evidence that to produce goods that are in much demand, many workpeople have some shockingly monotonous jobs, which appear to need the barest minimum of mental effort.

The visits have covered glass-making and the mass production of lamp envelopes, vacuum bottles and tumblers, etc., printing and bookbinding, cable and wire manufacture, motor tyre-making, brewing and the mass production of sweets, cakes and many other nice things. The Morris Motor Co. have promised an invitation to their Oxford factory in May.

Lectures have been diverse in subject and well received, attendances of 20-30 being the general rule.

Subjects were "The Telephone System in the U.S.A.," by E. A. Mayne, Esq., B.Sc., A.M.I.E.E., Telephone Manager, Guildford. "The Traffic Light System," by H. M. Wells, Esq., A.M.I.E.E., Area Engineer, Guildford. "Coal Mining," by Mr. J. Jones, a jointer member, and "Modern Gas Discharge Lamps," by Mr. L. G. Wallis. L. G. W.

Leicester Centre

After a lapse of several years the Leicester Centre of the Associate Section has been re-established. Mr. H. W. Sharman, Area Liaison Officer, opened the inaugural meeting on the 13th October, 1952, and outlined the aims of the Associate Section. A proposal to re-establish the Centre was carried unanimously and the following officers and committee were elected for the session:—*Chairman*, R. Medland; *Secretary*, T. E. Lord; *Assistant Secretary*, R. G. Willott; *Treasurer*, J. R. Cambridge. *Committee*, A. F. Allsopp, S. Bircham, A. S. Bradshaw, J. H. Leband, C. J. Wykes.

A general meeting was held on 5th November, 1952, when the main feature was a talk by Mr. H. C. Swinfield Wells, Technical Officer, on "Home Sound Recording," with demonstrations using equipment which he had constructed. A further meeting was held on Wednesday, the 17th December, 1952, when Mr. A. F. Allsopp, Technical Officer, gave a talk on his activities in connection with the Model Engineering Club, illustrated by some fine examples of model locomotives and marine engines. Both talks were well given and proved very interesting.

Looking ahead, the committee hope to provide a wide and varied programme likely to appeal to the membership at large. Two items of interest: a visit to the Leicester works of the Dunlop Rubber Co. was arranged for February, 1953; and the Leicester Radio Society have issued an open invitation to our members to attend their meetings.

It is hoped that the membership, now numbering 61, will wholeheartedly support the committee by their presence and helpful contributions at future meetings. T. E. L.

London Centre

With the end of the 1952/53 Session in sight, the London Centre is looking forward to its 21st year of activity. The 21st A.G.M. is being held on Wednesday, the 27th May, 1953, at the I.E.E., Lecture Theatre, Savoy Place, W.C.2, when the President, Col. C. E. Calveley, will read a paper on "Some Applications of Electronics to Telecommunications."

The programme for the 1952/53 session has been most successful, and the following papers have been read to our members:—

October.—"Call Queuing on Sleeve-Control Switchboards," by Mr. B. G. Woods.

November.—"Automatic Teleprinter Concentrator," by Mr. A. W. Haddon.

December.—"Photography in the Circuit Laboratory," by Mr. G. L. Mack and Mr. J. L. Martin.

January.—"Cordless-Type Switchboards," by Mr. N. V. Knight, B.Sc.(Eng.), A.M.I.E.E.

February.—"Projection Television," by Mr. R. W. Addie, M.A.

March.—"Beginnings of the Telephone Industry," by Mr. C. Hartwell.

April.—"Modern Radio Servicing," by Mr. G. King.

The first two have been submitted to the Senior Section for their Annual Competition for Association Section Members' Papers.

On the 7th, 8th, and 9th May, 1953, the London Centre Associate Section Radio Group is holding its 2nd Radio and Models Exhibition at the Metropole Hall. (For further information see page 39.)

Our Librarian, Mr. Skinner, is investigating the possibilities of forming a Technical Advice Panel, whereby an Associate Section Member requiring information on any subject can be referred to someone who can answer his query, and to periodicals and text-books where further information can be found.

Any Associate Section Members visiting London are cordially invited to attend our meetings. A. G. W.

Middlesbrough Centre

This Centre invited the members of the Tees-Side Amateur Radio Club to hear Mr. E. O. M. Grimshaw develop his theme, "The Electronic Organ." A keen audience fired a multitude of questions at the lecturer, who pursued each until complete satisfaction was obtained. Diagrams which accompanied Mr. Grimshaw's lecture further assisted us.

Mr. E. O. M. Grimshaw received the Telephone Manager's prize on 25th March, 1952, for his paper on "Domestic Radio" read in the previous session.

On 15th January, 1953, at the request of the Tees-Side Amateur Radio Club, members of the Associate Section attended a lecture entitled "Tips on Television," given by K. Sergeant, B.Sc. After a brief survey of television principles, Mr. Sergeant guided us through a circuit for use in the construction of our own sets. Following an interval for tea and biscuits, he supported his theoretical statements with demonstrations on his own home-constructed set.

Considered by and large, our attendances are encouraging and worthy of note.

As we close for press there is every indication that "Shared Service," a paper to be read by Messrs. R. Trotter and A. Chapman, will further add to its success in other Areas.

The "Two-Way Quiz" and Annual General Meeting will complete yet another year and add another chapter to the history of the Middlesbrough Centre of the Associate Section.

J. B.

Dollis Hill Centre

On the 1st January, 1953, a new Centre, known as the Dollis Hill Centre, was established at the Post Office Research Station, Dollis Hill, London, N.W.2. The Centre was originally part of the London Centre N.W. Area until October, 1951, when the Research Station Group was formed within the London Centre.

At the Inaugural Meeting of the Centre on 12th January, 1953, the following Officers were elected:—

Chairman, Mr. B. Gould; *Secretary*, Mr. D. E. Sexton. *Treasurer*, Mr. F. Thomas; *Librarian*, Mr. K. L. Taylor; *Visits Secretary*, Mr. H. W. Baxter. Representatives to the Committee were elected from the various Sections on the Station.

On the 9th May, 1951, the membership was 50, then, due to an improvement in facilities, the membership increased. At the inception of the Group in October, 1951, the membership was 100, and has now reached a total of 300.

The Centre already had a heavy programme of activities in progress. Eleven visits were organised during the latter part of 1952, including a visit to a Kent coalmine. The Lecture Programme arranged by our Talks Secretary, Mr. H. J. Hawkins, covered a series of six lectures during the winter of 1952-53.

The new Centre was formed with the object of providing better facilities for members, and to encourage non-members to join. Much of the praise for the formation of the Centre is due to the efforts of the Chairman, Mr. B. Gould, who formed the Research Station Group.

The Committee is also grateful for the help and advice given by the Liaison Officer, Mr. S. Welch, in the formation of this new Centre.

D. E. S.

Book Reviews

"Electrical Measurements and the Calculation of Errors involved (Part II A.C.)." D. Karo, Dip.Eng.E.S.E., A.M.I.E.E. Macdonald & Co. (Publishers), Ltd. 343 pp. 281 ill. 30s.

This is an unusual book which anyone who is already acquainted with the material, or who is using another textbook, will find stimulating to a fresh outlook. The calculation of errors follows the same lines as in Part I: that is to say, it is sound as far as it goes but it deals only with the errors caused by limited scale-reading accuracy and calibration accuracy. But the book cannot be unreservedly recommended for its declared purpose (which is to cover the syllabus of the London B.Sc.Eng. in Electrical Measurements) for two main reasons. First, many subjects are entered abruptly without any explanation of their relevance to the rest of the book. Comparison of this book with those of, for example, Golding or Hague will show its weakness in this respect. Second, there are many careless statements ranging from half-truths (which provide excellent exercise in discovering the conditions in which they are true) to plain errors of fact (of which the reviewer has counted about twenty).

Some of the diagrams are unsatisfactory. Admittedly a bridge network with screening and Wagner earth is bound to look complicated, but judicious use of heavier lines for main circuits and of broken lines for screens would have helped greatly. The entire absence of references cannot be excused on the irrelevant grounds stated in the Preface; there is nothing derogatory to Dr. Karo's book in wishing to have more detail than he has included in some matters. In one case (Butterworth's work on impurities in mutual inductors) one suspects that the author is himself not familiar with the literature.

The absence of an index may be forgiven because of the well-set-out Contents pages.

A.C.L.

"Modern Staff Training." F. J. Tickner, M.A. University of London Press Ltd. 150 pp. 12s. 6d.

The author is to be congratulated on his attempt to give "A survey of training needs and methods of today," and in the book on "Modern Staff Training" he has collected, for the first time it is thought, a good deal of information from industrial and commercial undertakings and other large organisations such as the Civil Service. He describes the

characteristic way in which training in the Civil Service has developed since the Assheton Report was published. It is probable that the training needs of other large undertakings may be similar to those in the Civil Service but it is felt that more convincing evidence should have been given. On page 101 we read "Nor can training be successful if the Personnel Manager, the Training Officer, or their staff feel that in the finances of the concern money is allocated to training as a luxury, and that training will be the first direction in which economies are to be sought in hard times." This view will persist in management until those who are responsible for training disprove it. Training is costly in time lost from productive work, teaching staff and overheads, and this expense can only be justified if the effectiveness and efficiency of training schemes are clearly demonstrated. Yet discussion on the economic problems of training has been omitted from the book and it would appear from page 13 that the main reason why a "Training Centre must be efficient and well conducted" is to impress newcomers.

Some guide on the proportions of formal training and "training on the job" for various types of job would have been an extremely valuable addition to the book.

The chapter on "Training the Supervisor" is based on the "Training Within Industry" (T.W.I.) methods which were designed primarily to help newly appointed foremen in a rapidly expanded industrial economy. Although they may form a useful basis for the design of courses on supervision, the rigidity of the instruction at the three institutes often fails to convince.

In the next chapter on "Training the Manager" the author makes the important point that managers must be selected from those who possess character and leadership. No training course in management will be effective unless students have these important qualities.

The importance of the correct selection and training of teaching staff is emphasised and the undesirability of adopting a compromise between staff available and those possessing teaching ability is stressed. How can training be efficient if bad or makeshift selections are made? What essential qualities are necessary in teaching staff and how are they to keep up to date? It is thought that the author's own experience of organising and conducting training courses would have increased considerably the value of the book which, in its present form, is limited even as far as the beginner is concerned.

H. R. H.

Staff Changes

Promotions

Name	Region	Date	Name	Region	Date
<i>Asst. Staff Engr. to Staff Engr.</i>			<i>Tech. Offr. to Asst. Engr.</i>		
Carter, R. O.	E.-in-C.O.	17.12.52	Forrest, J. N.	E.-in-C.O.	25.12.52
<i>Senr. Exec. Engr. to Asst. Staff Engr.</i>			Murray, W. J.	Scot. to E.-in-C.O.	3.1.53
Bevis, W. F.	H.C. Reg.	30.12.52	King, G. C.	E.-in-C.O.	4.2.53
Cameron, C. J.	E.-in-C.O.	3.2.53	Jones, R.	E.-in-C.O.	23.1.53
<i>Exec. Engr. to Senr. Exec. Engr.</i>			Storey, R. O. C.	E.-in-C.O.	14.2.53
Allan, F. W.	N.E. Reg.	8.12.52	<i>Exper. Offr. to Scientific Offr.</i>		
<i>Asst. Engr. to Exec. Engr.</i>			Harrison, J. C.	E.-in-C.O.	8.12.52
Baldwin, A. W. T.	L.T. Reg. to E.-in-C.O.	8.12.52	<i>Asst. Exper. Offr. to Exper. Offr.</i>		
Durrant, H. L.	L.T. Reg.	20.1.53	Hines, R. E.	E.-in-C.O.	19.1.53
Fairs, A. E.	L.T. Reg.	20.1.53			
Gale, C. M. S.	L.T. Reg.	20.1.53			

Transfers

Name	Region	Date	Name	Region	Date
<i>Chief Regl. Engr.</i>			<i>Asst. Engr.—continued</i>		
Beer, C. A.	L.T. Reg. to N.E. Reg.	11.12.52	Roberts, E.	E.-in-C.O. to Extl. Tele-comms. Exec.	10.12.52
<i>Area Engr.</i>			Rogers, J. A.	E.-in-C.O. to Extl. Tele-comms. Exec.	10.12.52
Pitcairn, A. C.	N.E. Reg. to S.W. Reg.	8.12.52	Martin, C. W. J.	E.-in-C.O. to Extl. Tele-comms. Exec.	10.12.52
<i>Senr. Exec. Engr.</i>			Singleton, N.	E.-in-C.O. to Extl. Tele-comms. Exec.	10.12.52
Neale, J.	E.-in-C. to G.C. H.Q.	29.12.53	Tait, W. A.	E.-in-C.O. to Extl. Tele-comms. Exec.	10.12.52
<i>Exec. Engr.</i>			Welch, W. T.	E.-in-C.O. to Extl. Tele-comms. Exec.	10.12.52
Shearme, J. N.	E.-in-C.O. to G.C. H.Q.	5.1.53	Cochrane, J.	Mid. Reg. to N.E. Reg.	31.1.53
Hughes, H. S.	E.-in-C.O. to G.C. H.Q.	2.2.53	Willis, S. T.	E.-in-C.O. to L.T. Reg.	1.2.53
Saunders, J. C.	S.W. Reg. to N.E. Reg.	9.2.53	<i>M.T.O. III.</i>		
<i>Asst. Engr.</i>			Stokes, F. W.	E.-in-C.O. to L.T. Reg.	1.2.53
Martin, A. C.	E.-in-C.O. to P. & T. Dept., Nigeria	21.12.49	<i>Tech. Asst. I.</i>		
Mackellar, A. C.	E.-in-C.O. to Trinity House Service	31.10.52	Trimmer, G. J. P.	L.T. Reg. to H.C. Reg.	9.2.53
Danes, J. E.	E.-in-C.O. to Extl. Tele-comms. Exec.	10.12.52	Thompson, J.	N.E. Reg. to Scot.	9.2.53
Jacob, J. A.	E.-in-C.O. to Extl. Tele-comms. Exec.	10.12.52	<i>Senr. Scientific Offr.</i>		
			Hill, L. W.	E.-in-C.O. to G.C. H.Q.	5.1.53

Resignations

Name	Region	Date	Name	Region	Date
<i>Asst. Engr.</i>			<i>Asst. (Scientific).</i>		
Stanhope, F. W.	E.-in-C.O.	20.12.52	Harbottle, Mrs. E. A.	E.-in-C.O.	1.12.52
Dodd, G. A.	E.-in-C.O.	12.1.53			
Glover, S.	E.-in-C.O.	31.1.53	Hall, Mrs. A. H.	E.-in-C.O.	31.12.52
Brewin, H. T. R.	H.C. Reg.	12.12.52			

Retirements

Name	Region	Date	Name	Region	Date
<i>Regl. Engr.</i>			<i>Asst. Engr.—continued.</i>		
Robinson, O. D.	Mid. Reg.	5.2.53	Lally, J.	N.E. Reg.	30.12.52
<i>Exec. Engr.</i>			Morse, F. H.	E.-in-C.O.	20.1.53
Wright, C. T.	H.C. Reg.	31.12.52	Durston, E. A.	S.W. Reg.	28.1.53
Layton, N.	L.T. Reg.	31.12.52	Edge, J.	E.-in-C.O.	3.10.52
Bateson, E. L. H.	E.-in-C.O.	31.1.53	<i>Inspector.</i>		
<i>Asst. Engr.</i>			Gray, W.	N.I. Reg (Health grounds)	21.10.52
Edmonstone, J. M.*	Scot.	9.8.52	O'Doherty, J.	N.I. Reg.	16.12.52
Leece, W.	N.E. Reg.	19.12.52	Sawyer, O. R.	N.E. Reg.	31.12.52
Smith, C.	N.E. Reg.	28.12.52	Foote, F. W.	N.W. Reg.	31.12.52
Bird, A. V.	E.-in-C.O.	31.12.52	Clarke, W. J.	L.T. Reg.	4.1.53
Dennis, E. W. B.	L.T. Reg.	31.12.52	Hunt, G. W.	L.T. Reg.	27.1.53
Wildig, A.	Mid. Reg.	31.12.52	Short, C. C.	H.C. Reg.	8.11.52
Thomson, E. B.	Scot.	31.12.52	Blyth, C. R.	H.C. Reg.	9.11.52
			Turner, C. W.	H.C. Reg.	20.11.52
			Fisher, F. C.	H.C. Reg.	28.12.52

* It is regretted that this entry was inadvertently included under "Deaths" in the January 1953 issue.

Deaths

Name	Region	Date	Name	Region	Date
<i>Senr. Exec. Engr.</i>			<i>Asst. Engr.—continued</i>		
Burgess, A. G.	E.-in-C.O.	26.12.52	Chaplin, H. T.	E.-in-C.O.	30.1.53
			Hardy, J.	N.E. Reg.	17.2.53
<i>Asst. Engr.</i>			<i>Inspector.</i>		
Bowman, A.	N.I. Reg.	5.12.52	Dewes, H.	N.E. Reg.	30.11.52
Waller, D. C.	H.C. Reg.	24.12.52	Parrett, A. W.	L.T. Reg.	26.12.52

CLERICAL GRADES

Promotions

Name	Region	Date	Name	Region	Date
<i>E.O. to H.E.O.</i>			<i>C.O. to E.O.—continued.</i>		
Fox, A.S.	E.-in-C.O.	22.9.52	Brown, G. W.	E.-in-C.O.	15.9.52
			Mariner, Miss E. M.	E.-in-C.O.	22.9.52
<i>C.O. to E.O.</i>					
Harris, E. A. J.	E.-in-C.O.	8.9.52	Noble, W. C.	E.-in-C.O.	22.9.52
			Stoddart, C. H.	E.-in-C.O.	20.11.52

Transfers

Name	Region	Date	Name	Region	Date
<i>E.O.</i>			<i>E.O.—continued.</i>		
Pollock, Miss K. J. M.	E.-in-C.O. to Ministry of Food	20.10.52	Wilson, J.	E.-in-C.O. to H.M.S.O., Belfast	1.11.52
			Richart, E. W. T.	A.G. Dept. to E.-in-C.O.	29.12.52

DRAUGHTSMEN

Promotions

Name	Region	Date	Name	Region	Date
<i>L. D'man to Senr. D'man.</i>			<i>D'man Cl. I to L. D'man.</i>		
Wright, L. J.	E.-in-C.O.	17.11.52	Kendall, E. C.	E.-in-C.O.	6.8.52
Edmondson, E. E.	E.-in-C.O.	1.12.52	Smith, G. H.	E.-in-C.O.	30.12.52
			Bradford, H. J.	E.-in-C.O.	5.1.53

BOARD OF EDITORS

H. FAULKNER, C.M.G., B.Sc., M.I.E.E., F.I.R.E., Chairman.
 W. WEST, B.A., M.I.E.E.
 L. F. SCANLEBURY, Whit.Sch., A.C.G.I., D.I.C., A.M.I.E.E.
 D. A. BARRON, M.Sc., A.M.I.E.E.
 H. G. BEER, Whit.Sch., A.C.G.I., A.M.I.E.E.
 E. DAVIS, A.M.I.E.E.
 L. CHANT.
 G. E. STYLES, A.M.I.E.E., Managing Editor.
 W. A. HUMPHRIES, A.M.I.E.E.
 J. P. HARDING, B.Sc.(ENG.), } Assistant Editors.
 A.M.INST.C.E., A.M.I.E.E.
 A. J. HUTCHISON, Secretary-Treasurer.

Copyright

The entire contents of this JOURNAL are covered by general copyright, and special permission is necessary for reprinting long extracts, but Editors are welcome to use not more than one-third of any article, provided credit is given at the beginning or end thus: "From the *Post Office Electrical Engineers' Journal*."

The Board of Editors is not responsible for the statements made or the opinions expressed in any of the articles in this JOURNAL, unless such statement is made specifically by the Board.

Communications

All communications should be addressed to the Managing Editor, *P.O.E.E. Journal*, Engineer-in-Chief's Office, Alder House, Aldersgate Street, London, E.C.1. Telephone: HEADquarters 1234. Remittances should be made payable to "*The P.O.E.E. Journal*" and should be crossed "& Co."

Binding Cases

Cases for binding are available, and may be obtained from the Local Agents for 3s. Subscribers can have their copies of volumes bound, at a cost of 10s. 6d., by sending the complete set of parts to the Local Agents or to the *P.O.E.E. Journal*, Engineer-in-Chief's Office, Alder House, Aldersgate Street, London, E.C.1. Orders for binding for Vols. 1-19 should indicate whether the original binding case with black lettering, or the later pattern with gold, is required. Cases with gold lettering are the only type stocked from Vol. 20 onwards.

Back Numbers

The price of the JOURNAL, which is published quarterly, is 2s. 6d. (2s. 9d. post free) per copy, or 11s. per annum, post free. Back numbers can be supplied, subject to availability of stocks, at 2s. 6d. each (2s. 9d. post free). Orders for back numbers may be sent to the *P.O.E.E. Journal*, Engineer-in-Chief's Office, Alder House, Aldersgate Street, London, E.C.1, or to the Publishers.

Employees of the British Post Office can obtain the *Journal* through Local Agents at the reduced price of 2s. per copy.

Advertisements

All communications relating to space reservations should be addressed to the Advertisement Editor, *P.O.E.E. Journal*, Alder House, Aldersgate Street, London, E.C.1. Communications regarding advertisement copy, proofs, etc., should be addressed to the Publishers, Messrs. Birch & Whittington (Prop. Dorling & Co. [Epsom], Ltd.), 49 Upper High Street, Epsom, Surrey.

Fine wires in telecommunication & electronic equipment
need



the only vitalised pure rosin cored Solder

ACTOL is the only fast-working cored solder which is chlorine free. Its *pure rosin* flux is vitalised by an exclusive process to increase its wetting power without altering its chemical properties ; it contains no additive. Furthermore, ACTOL has the unique Enthoven stellate core for rapid wall solder collapse and faultless fluxing. ACTOL leaves a hard, non-corrosive residue



of maximum insulation resistance. A.I.D. approved. In all standard tin/lead alloys, 10-22 s.w.g.

Please send for a sample of ACTOL or ask one of our technical advisers to call.

Perfect joints in precision instruments and delicate components need ACTOL, the only vitalised pure rosin cored solder.



Developed and manufactured at the Enthoven Solder Factory

MARKETED BY ENTHOVEN SOLDERS LTD., 89, UPPER THAMES ST., LONDON, E.C.4

Telephone : MANsion House 4533

INDEX TO ADVERTISERS

	PAGE
Airmec, Ltd.	xxviii
Alton Battery Co., Ltd., The	x
Automatic Coil Winder & Electrical Equipment Co., Ltd.	xxiii
Automatic Telephone & Electric Co., Ltd.	xii, xviii
Bennett College, The	ii
British Electric Resistance Co., Ltd., The	xxvii
Creed & Co., Ltd.	xxii
Edison Swan Electric Co., Ltd., The	xxix
E.M.I. Institute	ii
Enthoven Solders	iii
Ericsson Telephones, Ltd.	v
Evershed & Vignoles, Ltd.	xvii
Ferranti, Ltd.	viii
General Electric Co., Ltd., The	xiii-xiv
Great Northern Telegraph Co., Ltd.	xxiv
Hackbridge Cable Co., Ltd.	xxiv
Hivac, Ltd.	iv
Jones, Walter & Co. (Engineers), Ltd.	xxvii
Marconi Instruments, Ltd.	ix
Marconi's Wireless Telegraph Co., Ltd.	xi
Muirhead & Co., Ltd.	viii
Mullard, Ltd.	vi
Neill, James, & Co., Ltd.	xxviii
Painton of Northampton	vii
Pirelli-General Cable Works, Ltd.	xxix
Pitman, Sir Isaac, & Sons, Ltd.	iv
Pye, Ltd.	xv-xvi
Siemens Brothers & Co., Ltd.	xxi
Smith, Frederick, & Co.	ii
Standard Telephones & Cables, Ltd.	xix-xx
Sullivan, H. W., Ltd.	xxv
Telephone Manufacturing Co., Ltd.	xxiii
Tungstone Products, Ltd.	xxvi
Westinghouse Brake & Signal Co., Ltd.	xxv
Winn & Coales, Ltd.	ii

PITMAN

Telephony (2 vols.)

By J. Atkinson, A.M.I.E.E., Area Engineer, Post Office Engineering Dept. A standard textbook for Post Office engineers and students. With over 1,500 illustrations. Vol. I (General Principles and Manual Exchange Systems) 35/- net. Vol. II (Automatic Exchange Systems) 55/- net.

Alternating Currents in Telecommunications

By W. T. Palmer, B.Sc.(Eng.), Wh.Ex., M.I.E.E., A.M.I.Mech.E. 4/- net. "Should be of value to the student who finds the often condensed treatment of the average textbook difficult to follow."—
TECHNICAL JOURNAL.

Radio and Radar Technique

By A. T. Starr, M.A., Ph.D., M.I.E.E. A survey of modern knowledge concerning essential methods and techniques of radio and radar. Special attention is paid to noise, microwave techniques, waveforms, pulse circuit techniques, and electronic tubes. 75/- net.

The Induction Motor

By Herbert Vickers, Ph.D., M.Eng., A.Inst.P., M.I.E.E. The Second Edition of this authoritative textbook, covering the theory, design and applications of induction motors. A great deal of new material is included in this edition. With 250 illustrations. 70/- net.

Electric Wiring Diagrams

By W. Perren Maycock. Fourth Edition, revised by A. Serner, B.Sc., A.C.G.I., A.M.I.E.E. An up-to-date and reliable reference work. 257 diagrams. 8/6 net.

PITMAN, Parker Street, Kingsway, London, W.C.2

SUB-MINIATURISATION

HIVAC

THE FIRST TO
GET DOWN
TO IT!

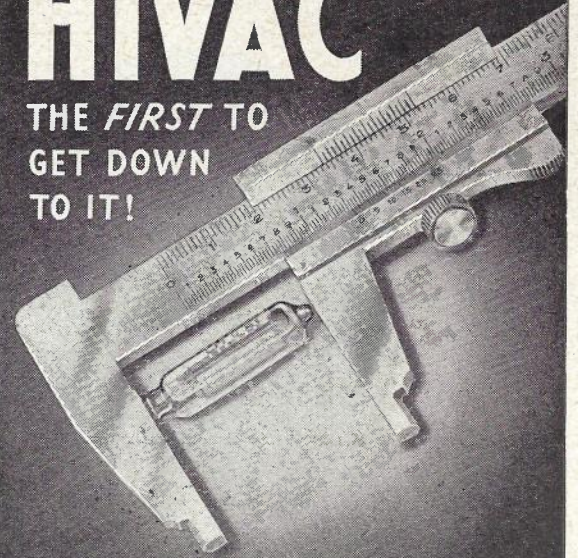

XFY 31

Beam Tetrode
Sub-Miniature Output Valve

TYPICAL OPERATION

Filament Voltage	1.25	1.25 V.
Filament Current	12.5	12.5 mA.
H.T. Voltage	22.5	30 V.
Control Grid Voltage.....	0	-2.75 V.
Power Output.....	1.8	6.0 mW.

The maximum cross-section is only 8 mm. x 6 mm. with a maximum glass length of 35 mm. and the nominal filament current is 12½ mA.

These features, in conjunction with the high efficiency of the XFY31 permit still greater saving in space whilst maintaining exceptionally fine performance.

HIVAC

THE SCIENTIFIC
VALVE

Hivac Ltd.

Telephone: HARrow 2855
GREENHILL CRESCENT, HARROW-ON-THE-HILL, MIDDLESEX

Cold Cathode Tubes



DEKATRONS

TRIGGER TETRODES

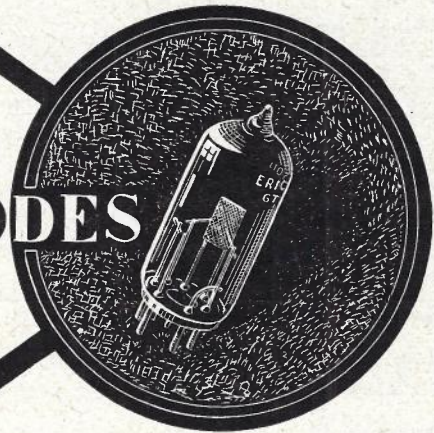

STABILISERS

*Descriptive Catalogue available on
application to:-*

WORKS:
BEESTON,
NOTTINGHAM
Beeston 54225

TELEPHONES
Ericsson
LIMITED

HEAD OFFICE:
22, LINCOLN'S INN FIELDS,
LONDON, W.C.2
HOLborn 6936



Grinding Mullard 'Ticonal' permanent magnets to required size.

MAGNETIC MATERIALS Extensive research and manufacturing facilities have established Mullard as the leading producers of magnetic materials. They were the first, for example, to introduce Ferroxcube, the world's most efficient magnetic ferrite; 'Ticonal' anisotropic permanent magnets, renowned for their high stability and high energy output; and Ferroxdure, an entirely new type of permanent magnet with the insulating properties of a ceramic.

The wealth of experience gained from these developments is available to all users of magnetic materials through the Mullard advisory service. An enquiry to the address below will put a team of specialised engineers at your disposal.



Mullard

'TICONAL' PERMANENT MAGNETS · FERROXDURE PERMANENT MAGNETS
FERROXCUBE MAGNETIC CORE MATERIAL

MULLARD LTD., COMPONENT DIVISION, CENTURY HOUSE, SHAFTESBURY AVENUE, LONDON, W.C.2.



By Appointment to the Professional Engineer..

Attenuators

Faders

Stud Switches and Toggle Switches

Wirewound Potentiometers

High Stability Carbon Resistors

Wirewound Resistors

Plugs and Sockets

Terminals

Knobs Dials and Pointers

PAINTON

Northampton England

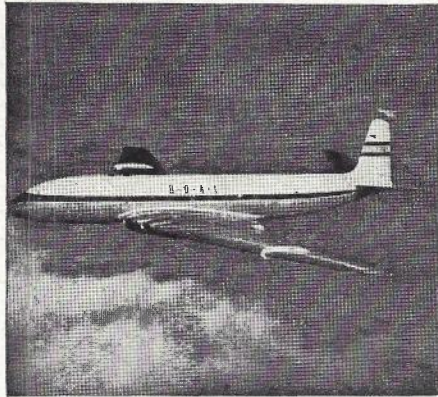

VOLUME 4 NUMBER 2 APRIL 1952

**THIS INTERESTING QUARTERLY
WILL BE MAILED *FREE*
TO ANY PART OF THE WORLD
POST THIS COUPON TODAY**

MUIRHEAD & CO. LTD · BECKENHAM · KENT · ENGLAND

Please mail me, free of charge, your quarterly journal "technique"

NAME _____

POSITION _____

COMPANY _____

ADDRESS _____

76

MUIRHEAD & CO. LTD · BECKENHAM · KENT · ENGLAND
PRECISION ELECTRICAL INSTRUMENT MAKERS

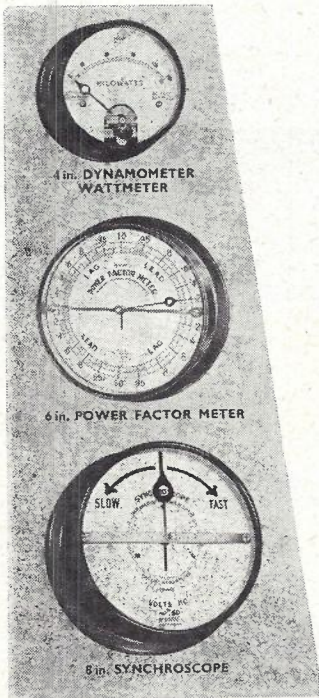

FERRANTI

ROUND PATTERN

Switchboard Instruments

**DIALS 4", 6" and 8", open or protected.
PATTERNS projecting or flush. TYPES**

Moving coil and moving iron ammeters and voltmeters. Dynamometer wattmeters. Power Factor Meters. Induction wattmeters. Frequency Meters. Synchrosopes. Synchronous Clocks.

Square patterns flush mounting also supplied in above sizes and types.

Write for descriptive lists

FERRANTI LTD · HOLLINWOOD · LANCs

London Office: KERN HOUSE, 36 KINGSWAY W.C.2



Valve millivoltmeter

TYPE TF 899

A SENSITIVE electronic millivoltmeter of wide frequency response, the instrument is primarily intended for the measurement of small r.f., v.f. and a.f. voltages where a high input impedance is essential; in addition to its normal routine applications, it is useful as a signal tracer, as a low admittance resonance indicator and as a detector of amplitude modulation. Particular applications are as an aid in television receiver development and in the investigation of radio-gramophone performance, including direct tests on pick-ups in conjunction with standard frequency or gliding tone records.

The frequency range extends from 50 c/s to 100 Mc/s, and the three measurement ranges are 0-150mV, 0-500mV and 0-2000mV; the power pack is arranged for operation from a.c. supplies.

The Valve Millivoltmeter is of compact design, is portable and extremely convenient to use. It weighs only 8 lbs.



MARCONI INSTRUMENTS

SIGNAL GENERATORS • BRIDGES • Q METERS • OUTPUT METERS
WAVE METERS • WAVE ANALYSERS • BEAT FREQUENCY OSCILLATORS

MARCONI INSTRUMENTS LIMITED • ST. ALBANS • HERTFORDSHIRE

Midland Office: 19 The Parade, Leamington Spa.
Northern Office: 30 Albion Street, Kingston-upon-Hull.
Export Office: Marconi House, Strand, London, W.C.2

This is King's Pond— and its waters almost lap the bricks of the Alton Battery Works' south-west wall. It is part of the Company's property—a 5-acre asset in real estate. And a symbol of assets in wider terms than accountancy covers. Alton is a country town—with a full, rounded, contented life of its own. A town where people have not yet changed to personnel. A town where families take root—and son follows father up to the Battery Works. A place where a man's proper pride in himself and his folk and the life he leads is reflected in doing things just that all-important bit better than 'up-to-specification.' And Alton batteries are made by Alton men

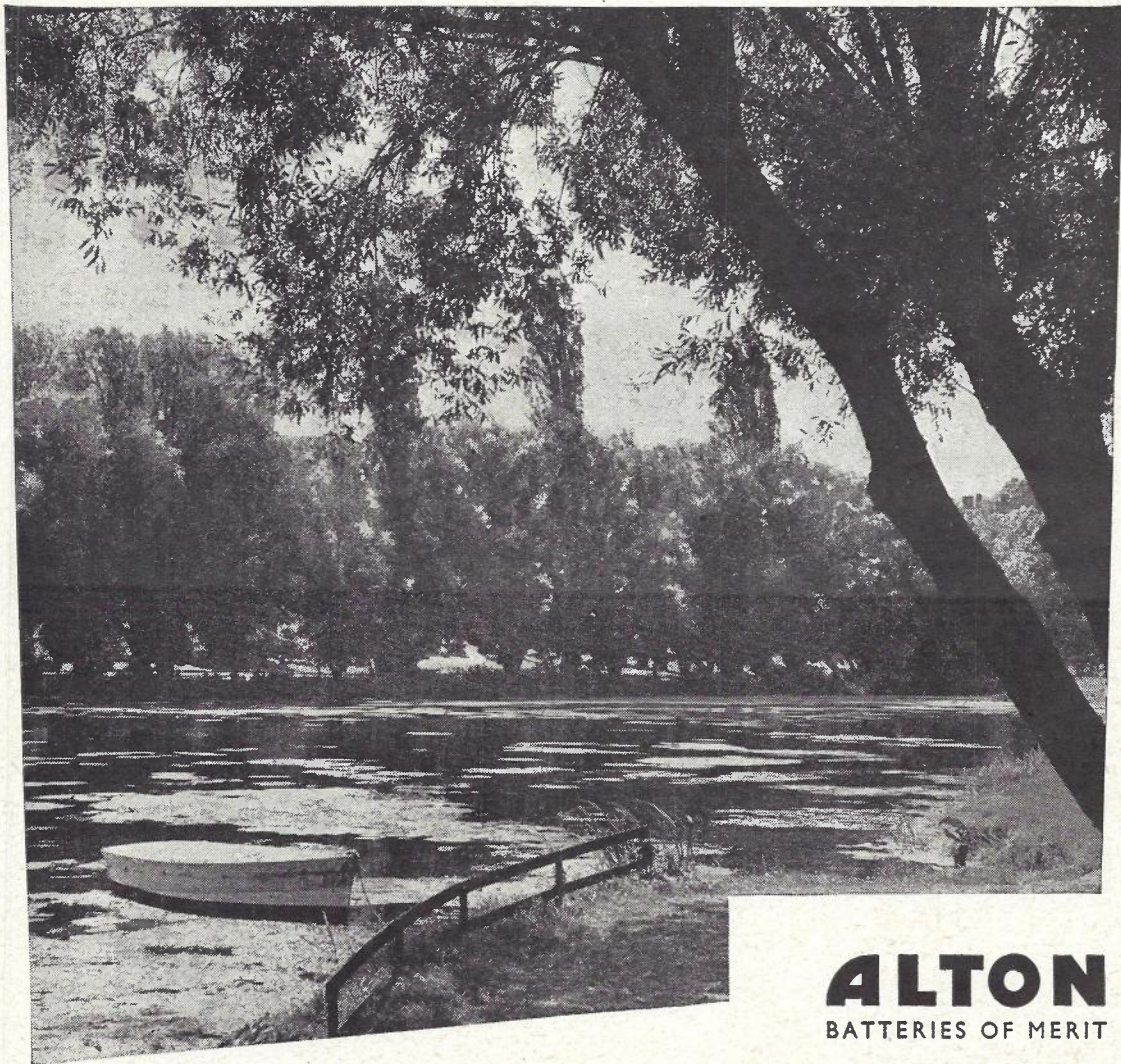

ALTON
BATTERIES OF MERIT

Alton stationary batteries: 10 to 15,000 Ah. Also in regular production, renewal plates for all makes of battery, British and Continental.

A24A

The Alton Battery Company Limited · Alton · Hants · Telephone: Alton 2267 and 2268 Telegrams: Battery, Alton

MARCONI communication systems



serve mankind

The jungle is no longer the barrier which for so many centuries hampered the progress of communications.

Guglielmo Marconi's invention of wireless overcame this obstacle just as it overcame

the ocean and the desert. The Company which he founded is still exploring, in the same exacting way, new ideas and techniques for bringing communications more fully into the service of mankind.



SURVEYED



PLANNED



INSTALLED

MARCONI'S WIRELESS TELEGRAPH COMPANY LTD · CHELMSFORD · ESSEX

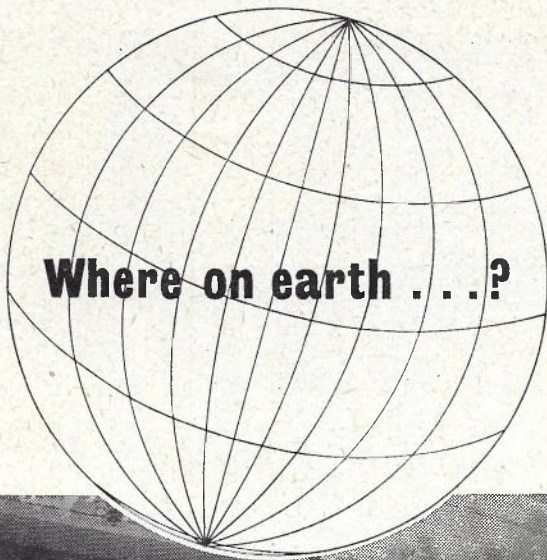

Aden or Aberystwyth, Yucatan or Great Yarmouth . . . the area makes little difference, for this mobile A.T.E. v.h.f. survey unit is specially equipped to undertake propagation and topographical surveys on behalf of Telecommunication Administrations and other customers *anywhere*.

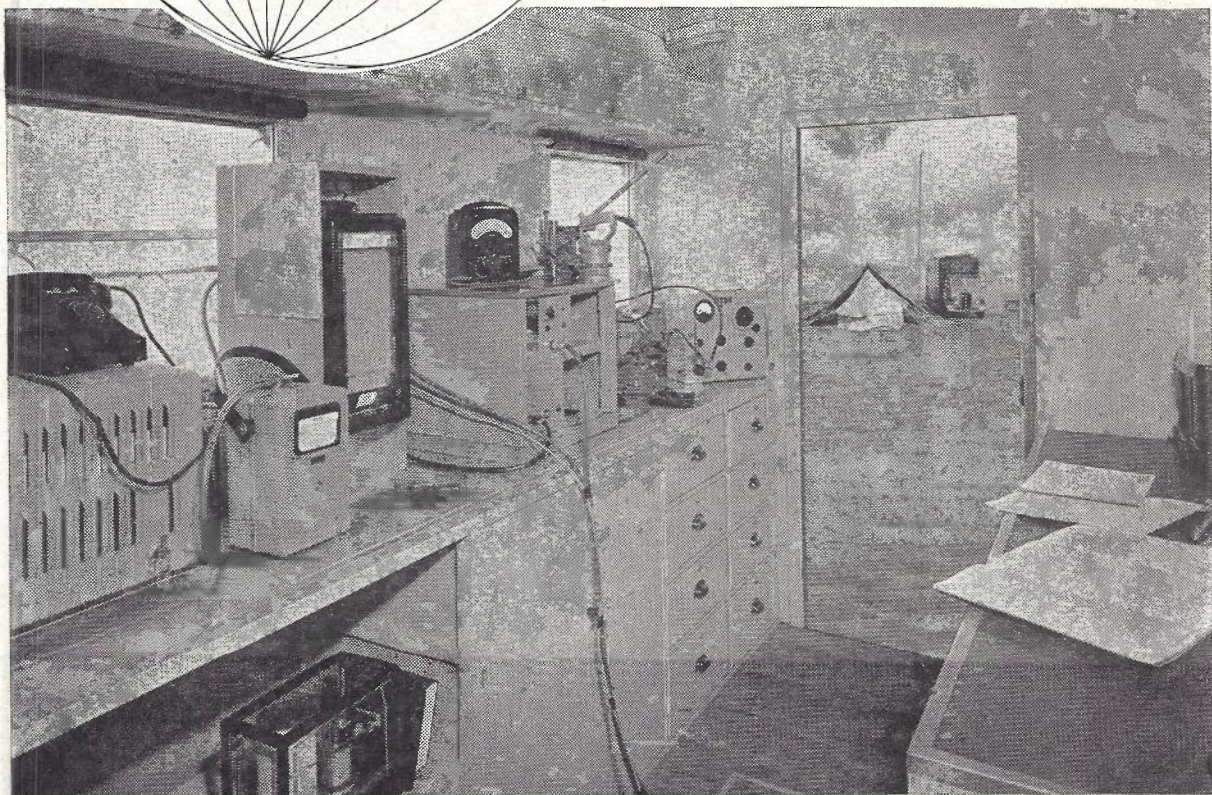

An effective survey on site will prove a sound investment in the planning of all radio telephone systems and ensure that the required system performance is obtained at the most economic cost to the Administration. Such surveys, taking into account all relevant propagational and meteorological data, ensure that the most suitable route is selected to meet local conditions and in particular that all stations, both terminal and repeater, are sited to the best advantage . . .

AUTOMATIC TELEPHONE & ELECTRIC CO. LTD.

RADIO AND TRANSMISSION DIVISION · STROWGER HOUSE, ARUNDEL ST., LONDON W.C.2
Telephone: TEMple Bar 9262.

Cablegrams: Strowgerex London



ATI4281-BX107



TWO MILLION

CALLS ALREADY -

- now it's on the third !



THE GENERAL ELECTRIC COMPANY LIMITED OF ENGLAND



The British Post Office standard durability requirement for selector switches is a life of 1,000,000 calls, representing 20 years' normal service. SE 50 selectors taken from the production line will each complete over 2,000,000 calls, the equivalent of 40 years' trouble-free service, without readjustment or replacement of any major part.

AN SE 50 SELECTOR WAS SUBMITTED TO A SCRUPULOUS EXAMINATION AFTER 2,000,000 CALLS, WITH THE FOLLOWING INSPECTION RESULTS:—

PART	CONDITION
Private wiper	Replaced after the first million calls. Worn but still usable if adjusted after the second million.
Line wipers	Slight wear.
Vertical guide teeth	Wear just perceptible.
Vertical and rotary ratchet teeth, pawl, pawl stops, armature bearings and detents	Wear just perceptible.
Vertical detent spring	Tension reduced—still perfectly workable.
Play in shaft spline	Increased by less than 0.002 in.
Vertical off normal spring set	Still functioning quite correctly.
Vertical and rotary armature travel	As specified originally
Wear on all other parts not mentioned above ...	No evidence.

This SE 50 selector has begun its third million-call life-test.



cutting the cost of maintenance

TELEPHONE, RADIO AND TELEVISION WORKS, COVENTRY

Multichannel

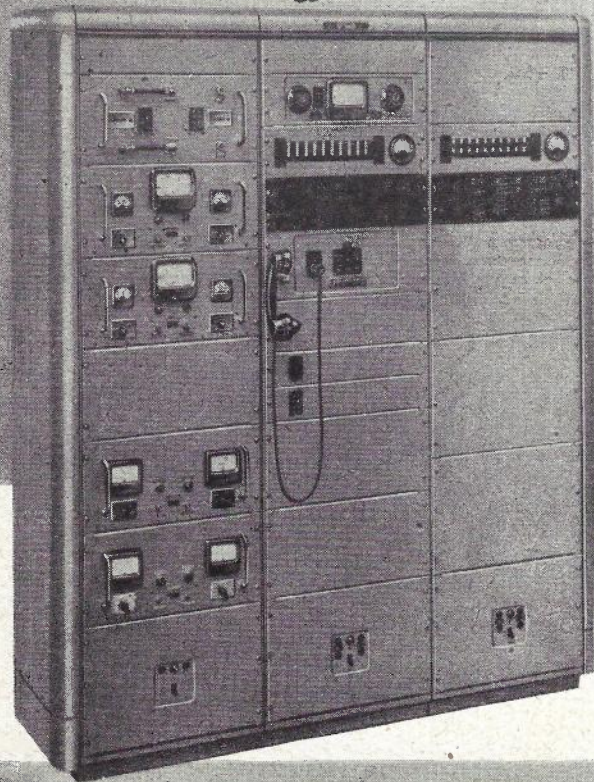
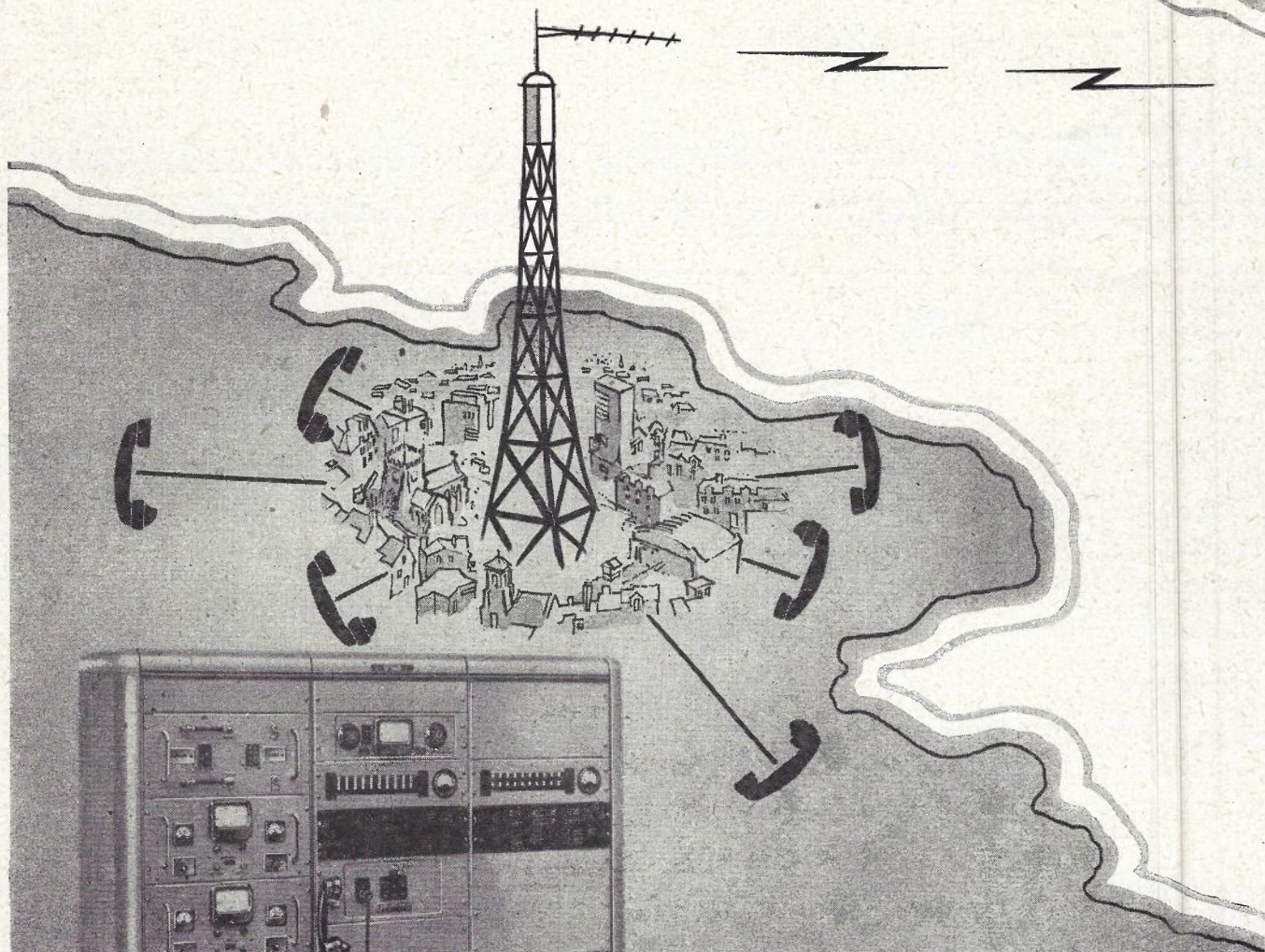

Designed and Manufactured

*Enquiries may be addressed
to either company*

PYE LIMITED
Cambridge,
England.

ERICSSON TELEPHONES LTD
22, Lincoln's Inn Fields,
London, W.C.2. England.

Radiotelephony

A major contribution toward the rapid establishment of communications in overseas territories, the Pye-Ericsson V.H.F. multiplex radio-telephone system has been fully developed to provide reliable telephone links wherever wire and cable circuits are impractical or, as is often the case, uneconomic. Standard carrier technique is retained and the system will commend itself to administrations already combining speech channels for transmission over wire circuits. The Pye-Ericsson V.H.F. multiplex radio-telephone system is the result of close collaboration between the two companies.

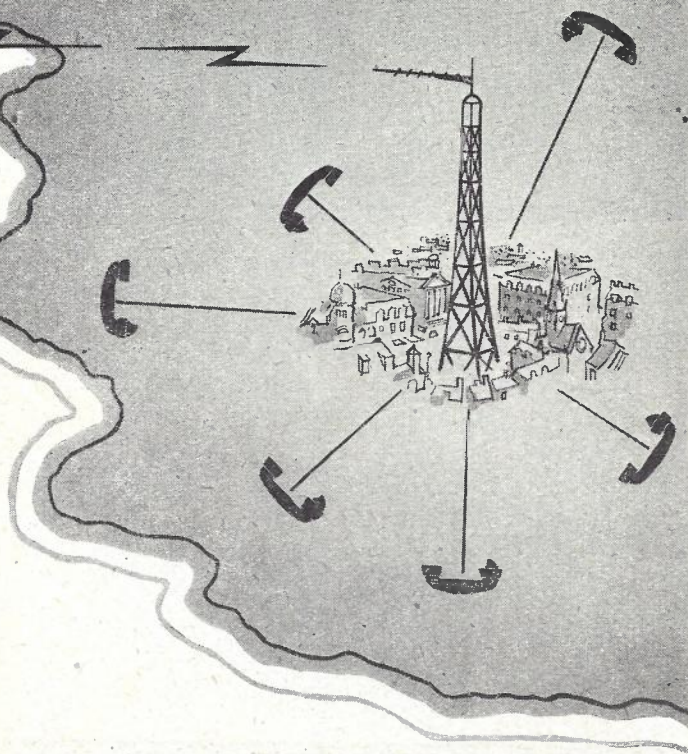

by *PYE LIMITED and ERICSSON TELEPHONES LIMITED*

Engineers interested in working on tele-communication projects are invited to apply to Pye Ltd. for full details of positions available.





GREECE. This picture shows officials of Telecommunications Organisation of Greece Ltd., using a "Megger" Insulation and Continuity Tester, Series 2, during a routine check at a telephone exchange in Greece.



HOLLAND. "Megger" Testers are used by the Dutch Post Office. This photograph shows Dutch P.O. engineers using a 500 volt Bridge-Megger Varley Testing Set to test a faulty line of a telephone cable in a polder-dike.

"MEGGER" TESTERS SERVE WORLD COMMUNICATIONS

UNITED KINGDOM. 64% of all faults on the 34,000 miles of main underground Post Office cables in the United Kingdom are located by "Megger" Testers.

ITALY. The Societa Telefonica Tirrena, which operates the telephone lines of Liguria (Genoa and the Riviera), Tuscany, Central Italy, the Vatican City and the Island of Sardinia, uses "Megger" Insulation Testers in the maintenance and localisation of faults in cables balanced in groups between cities.

AUSTRALIA. Bridge-Megger Testers prove equally valuable to the Post Office down under. Instruments equipped with Varley fault localisation facilities are used extensively by the Australian Postmaster-General's Department for the location of faults on underground cables. They report that "it is outstanding when used to perform this function."

ALL OVER THE WORLD the famous series of "Megger" Insulation Testers are used by public authorities, industrial undertakings and commercial enterprises because these instruments are more accurate, more reliable and sturdier in use.

For full details send for Publication X051/I-8.



Telephone: Chiswick 3670

EVERSHED & VIGNOLES LIMITED

ACTON LANE WORKS · CHISWICK · LONDON · W.4

Telegrams: Megger, Chisk, London

Cables: Megger, London
6/76

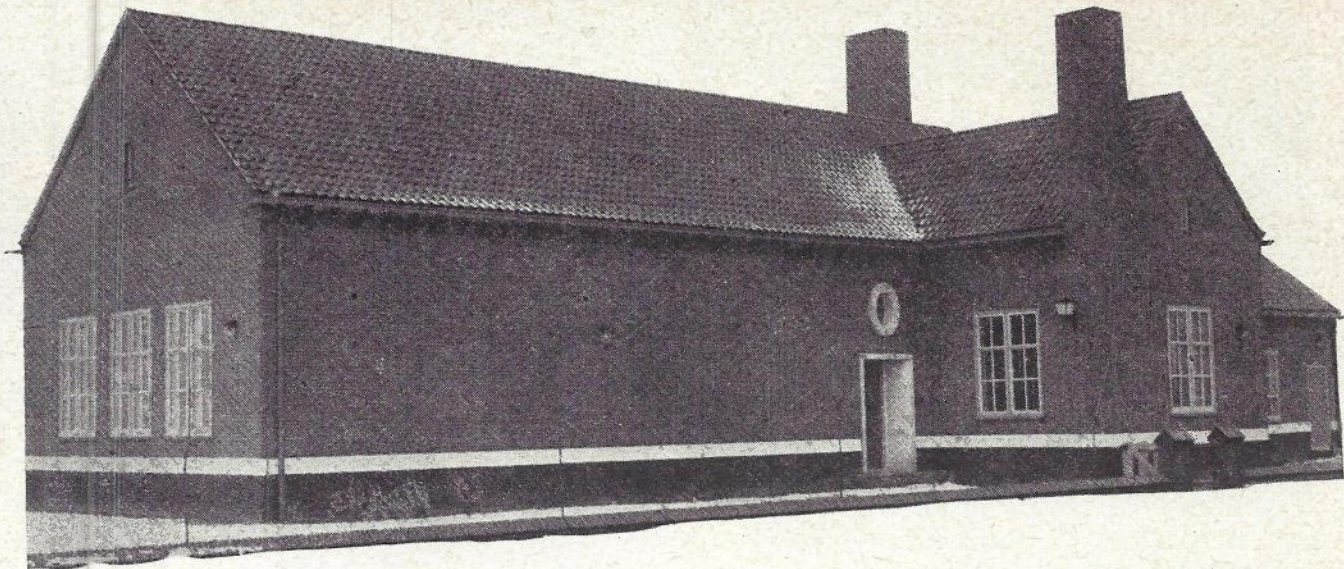

Another Strowger Exchange

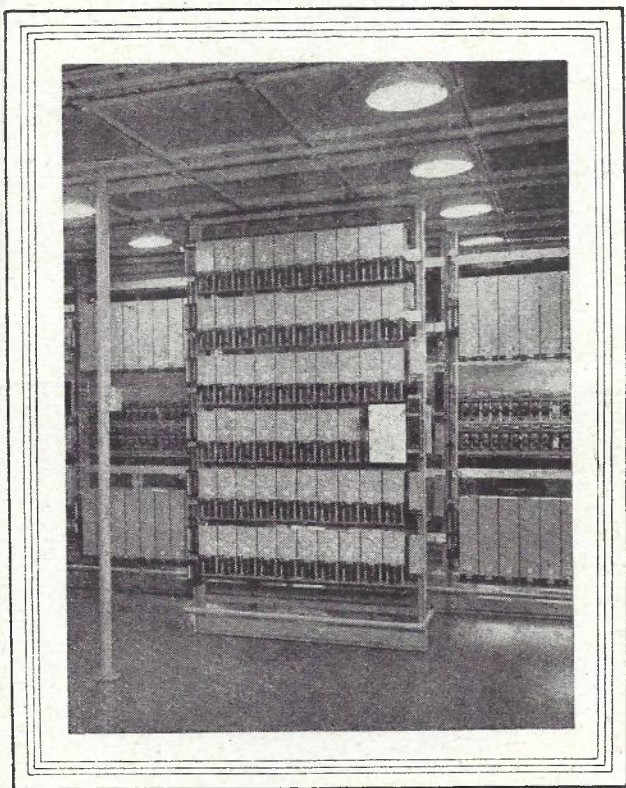

Middenmeer Sector Exchange is one of the latest to be commissioned by the Netherlands Postal and Telecommunication Services as part of a nation wide scheme of automatization. Type 2027 equipment, designed by Automatic Telephone & Electric Co. Ltd., was specified for Middenmeer and other exchanges being built by the Company for this Administration, and the first exchange of this type was put into service at Blokker in January 1948. Since then exchange equipment totalling over 40,000 lines has been installed, or is on order.

The Netherlands P.T.T. were pioneers in the development of national dialling, and the present network is designed on this basis. Provision is made for alternative routing and automatic trunk metering.

Automatic Telephone & Electric Co. Ltd.

Export Department: Strowger House, Arundel Street, London W.C.2

Telephone: TEMple Bar 9262. Cablegrams: Strowgerex London. Strowger Works, Liverpool, England.



AT. 7771-A104

Communication

Standard Systems in Service



Britain's largest Private Telephone Exchange, serving the new Government offices on Victoria Embankment, was designed, manufactured and installed by S.T.C. Fully automatic, it is connected with the G.P.O. system via the Trafalgar exchange, and has its own direct channels to Toll and Trunk exchanges.



Standard Telephones

(TELECOMMUNICATION)

Connaught House, Aldwych,

Cairo

Dublin

Johannesburg

and Control

Standard systems include:—

Standard's wide resources, their long experience in the design and manufacture of systems and equipment for telecommunications and control have enabled them to produce an extensive range of apparatus for use in all parts of the world.

These resources and experience are at your service, either for the systems listed or for their development to meet specific needs, as well as for the supply of equipment, materials and components including:—

Power Factor Correction

- Capacitors
- Magnetic alloys
- SenTerCel Selenium Rectifiers
- Thermionic Valves
- Quartz crystals

- Telephone
- Telegraph
- Teleprinter
- Radio Broadcasting
- Radio Communication
- Radio Navigation
- Sound Reproduction
- Remote Control
- Remote Indication
- Telemetry
- Railway Signalling
- Railway Control
- Power Cable
- Communication Cable
- Airfield Lighting Control
- Street Lighting Control
- Fire Alarm
- Totalisator
- Public Indicator
- Signalling (Office and Factory)

and Cables Limited

ENGINEERS)

London, W.C.2, England

Karachi

New Delhi

Salisbury

SIEMENS

12 Channel

CARRIER TELEPHONE EQUIPMENT

Type CS 12/C

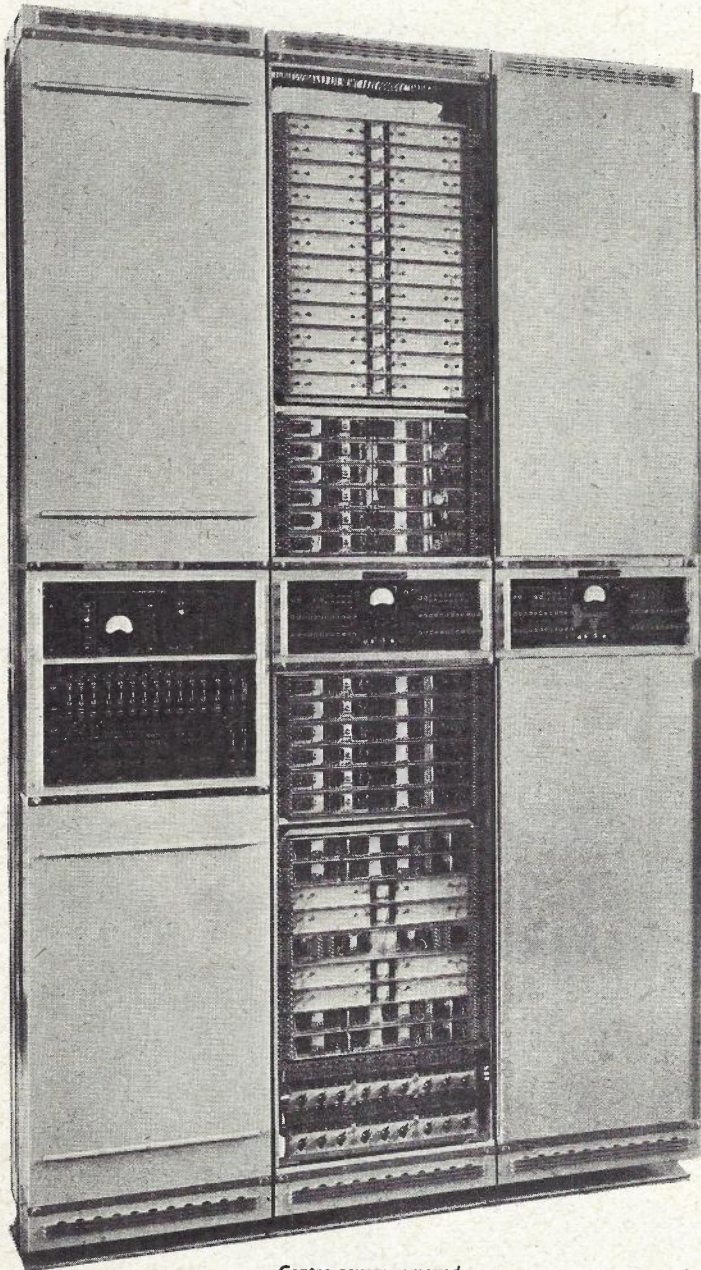

Centre covers removed

THE ILLUSTRATION SHOWS A TYPICAL SIEMENS CARRIER TELEPHONE TERMINAL EQUIPPED FOR 24 CHANNELS COMPLETE WITH CARRIER SUPPLY, LINE AMPLIFIERS AND FILTERS, RINGERS AND TERMINATIONS.

- Complying in all respects with C.C.I.F. recommendations for 12 channel carrier systems.
- Operated from A.C. Mains and suitable for connection to underground cable, overhead line or radio link systems.
- Incorporating the new Siemens method of mounting apparatus to give a compact equipment while providing accessibility and ease of maintenance.

SIEMENS BROTHERS & CO., LIMITED
WOOLWICH • LONDON • S. E. 18.

Facsimile

ELECTRONIC MESSAGE COMMUNICATION

Desk-Fax



THE Desk-Fax is a simple electronic instrument for transmitting and receiving written messages between remote locations.

Handwriting, typewritten matter and sketches are reproduced with equal facility and the highest fidelity.

It is only necessary to wrap the message around a cylinder and press a button. Transmission takes only two minutes.

The Desk-Fax does not make errors.

It's small, it's fast, it's silent in operation and it's dependable.

Creed & Company Limited

TELEGRAPH ENGINEERS

CROYDON · ENGLAND

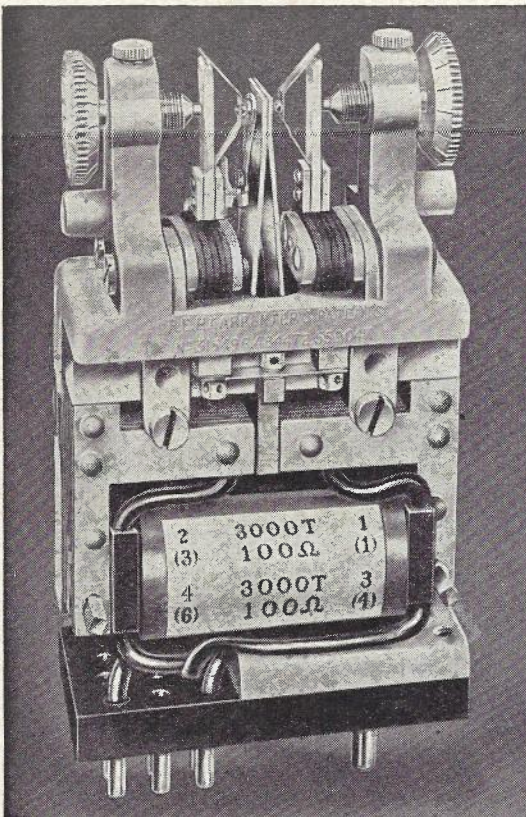

CARPENTER POLARIZED RELAY TYPE 4

The chief characteristics of this relay are low transit time—high contact pressure—freedom from contact chatter and positional error—high sensitivity—stability—symmetrical action—and ease of adjustment.

On V.F. dialling systems its use facilitates the design of sensitive receiving equipment, and on trunk telephone circuits the relay's high sensitivity enables it to respond to D.C. dialled impulses received over unrepeaters trunk lines of up to 100 miles long.

It is particularly suitable as an impulse accepting relay when a minimum of signal distortion is imperative, and because of the excellent change-over action and absence of contact chatter the relay is unequalled for impulsing the selector magnets in teleprinter automatic switching systems.

The relay responds satisfactorily to frequencies up to 100 c/s, when the contact gap is adjusted to 0.004 in. nominal, without serious bias disturbance. It can be left connected to line whilst awaiting a clearing signal, there being little distortion of through signals since the total leak can be of the order of 10,000 ohms.

Dimensionally the relay is interchangeable with the "3000" type relay. Terminations can either be made by means of a 12-pin plug base as illustrated, or with soldering tags in place of the pins. Protection is given by a magnetic screen and a transparent cap which is removable for contact adjustments.

Complete details supplied on request.

Manufactured by the Sole Licensees:—

TELEPHONE MANUFACTURING COMPANY LIMITED

Contractors to Governments of the British Commonwealth and other Nations

HOLLINGSWORTH WORKS · DULWICH · LONDON S.E.21 TEL: GIPSY HILL 2211 (10 LINES)



Electric

SOLDERING TOOLS

*for SPEED, ECONOMY
and BETTER WORK*

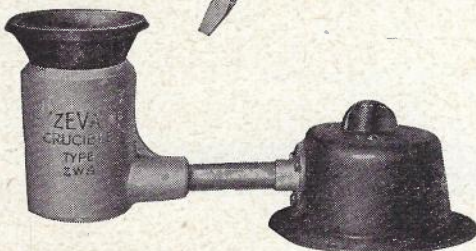

The news that this famous range of Soldering Irons and Crucibles is again available has been welcomed in numerous branches of industry everywhere. Zeva Tools are unquestionably without equal for efficiency, economy and trouble-free long life.

- ZEVA heating elements never need renewal. They last the life of the tool.
- ZEVA Irons can be left switched on all day without detriment to the tool.
- ZEVA current consumption for rated temperature is less than any other make of tool.
- ZEVA initial cost is the only cost.
- ZEVA Irons are guaranteed.

Write for complete
Illustrated Catalogue:—

THE AUTOMATIC COIL WINDER & ELECTRICAL EQUIPMENT CO., LTD
Winder House, Douglas Street, London, S.W.1

Phone: VICTORIA 3404-9

Z1/P2/ZWS

G.N.T.

REPERFORATOR MODEL 457

A truly synchronous reperforator for
morse code.

Speed range:

40-200 words per minute without
gear changes.

Supplied with A. C. or D. C. motor
as required.

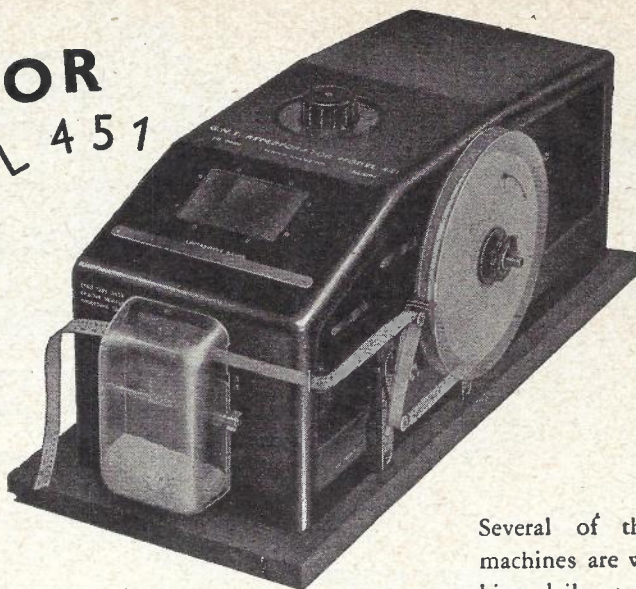

Several of these
machines are wor-
king daily at 180
words per minute.

★ Write for comprehensive catalogue.

THE GREAT NORTHERN TELEGRAPH COMPANY'S FACTORY

4, SYDHAVNS PLADS
COPENHAGEN SV . DENMARK



LONDON OFFICE: 5, ST. HELENS PLACE
LONDON E.C.3.

POWER LIGHTING TELEPHONY

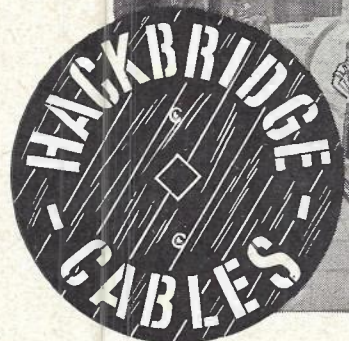

HACKBRIDGE
Cable Company Limited

KELVIN WORKS, HACKBRIDGE, SURREY
In Association with BRYCE ELECTRIC CONSTRUCTION CO. LTD.
Branches at BIRMINGHAM, BRISTOL, CARDIFF, MANCHESTER, NEWCASTLE, SHEFFIELD

THE PIONEERS

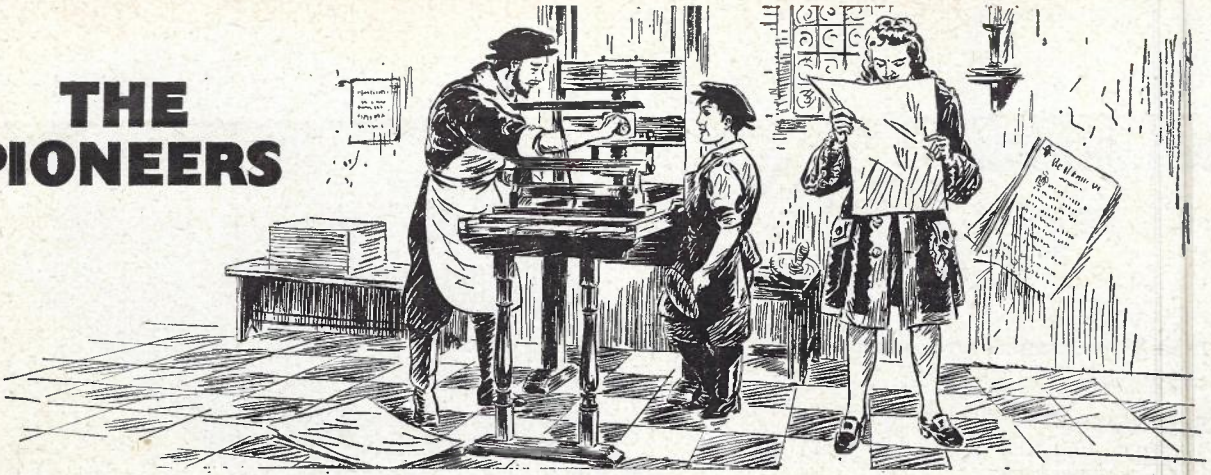

OF METAL

RECTIFICATION

Following the invention of movable type, printing, encouraged by many patrons including Peter the Great, advanced rapidly. Pioneers of this new method of reproduction soon flourished in many countries, spurred on by the enormous and hitherto unsatisfied demand for reading-matter. Progress born of necessity is evident also in the development of Metal Rectifiers. Pioneered by Westinghouse, to-day they meet every operational requirement throughout a wide range of applications, without loss of performance. Two instances are rectifiers for operating in ambient temperatures of 70°C, and a new lightweight rectifier for d.c. power supplies on aircraft. If you are a potential rectifier user we welcome your enquiries, and will be pleased to supply, to your requirements, full details of . . .



METAL RECTIFIERS

Dept. P.O.4., WESTINGHOUSE BRAKE & SIGNAL CO., LIMITED, 82 YORK WAY, KING'S CROSS, LONDON, N.1

SULLIVAN & GRIFFITHS

DIRECT READING VARIABLE CONDENSERS

WITH NOVEL AIR CAPACITANCE
DECADE RANGE EXTENSION

This air dielectric condenser comprises a decade of air capacitance and a continuously variable air condenser thus giving a scale accuracy ten times that of an ordinary variable condenser of the same range.

Thus a decade of capacitance is provided—permanent in value and entirely free from loss, the only loss present in the complete combination of decade and variable condenser being that due to the solid insulating material which is ordinarily employed in the construction of the latter.

The variable condenser has a range of 100 μ F which is extended to 1100 μ F by ten increments of 100 μ F, all adjusted with accuracy so that the decade is absolutely direct reading in μ F, no corrections or calibration being necessary.



LIST No. C880

H. W. SULLIVAN, LTD., LONDON, S.E. 15.

POWER *behind the lines*

TUNGSTONE PLANTE CELLS are being supplied to the British Post Office and Post and Telegraph Departments in many countries overseas. They conform fully to G.P.O. Standard specifications.

OPEN TYPE CELLS

Similar to the illustration here, these are available in glass and/or lead lined wooden boxes in capacities from 100 a.h. to 5000 a.h.

REPLATALS

We are in a position to supply plates for the replating of any existing Plante Battery.

ENCLOSED TYPE CELLS

As illustrated on the left these are in moulded glass boxes with sealed-in lid. Capacity range from 10 a.h. to 200 a.h.

HIGH VOLTAGE TELEPHONE BATTERIES

Portable Type. Standard layout for 50 volts, in waxed hardwood crates, exactly to the requirements of the G.P.O.

Overseas customers are invited to cable or write their enquiries for batteries or parts. Visitors to London are welcome at our offices (just off Fleet Street).

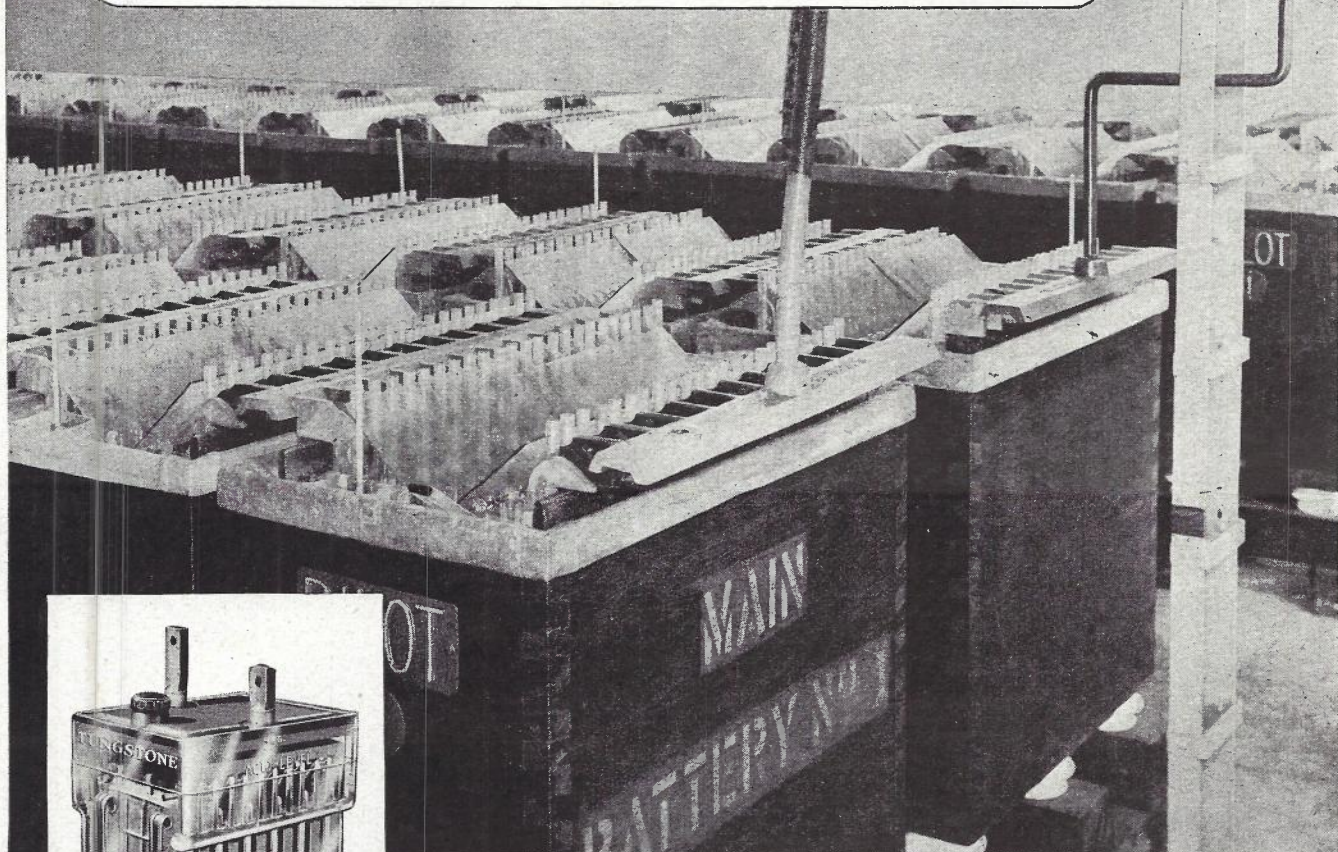

TUNGSTONE Batteries

For further particulars write: **TUNGSTONE PRODUCTS LIMITED**
10 SALISBURY SQUARE · LONDON · E.C.4 · ENGLAND · Cables: "Dilutum" London

The problem of

maintaining constant Voltage!

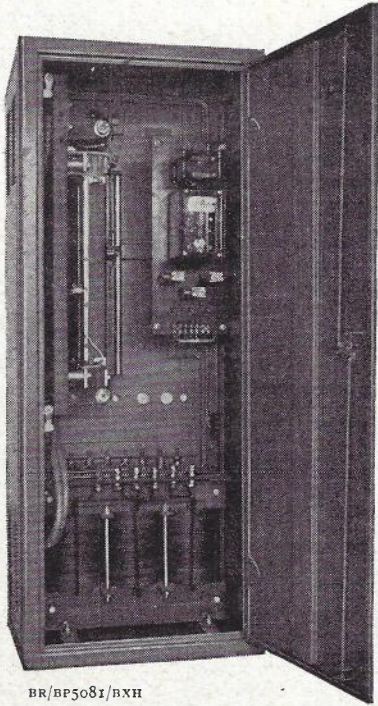

BR/BP5081/BXH

25KVA, 3 phase,
floor mounting cubicle
type fully automatic
Voltage regulator.

Users of industrial and scientific electrical equipment that is normally sensitive to voltage fluctuations are constantly faced with the problem of maintaining a constant supply voltage.

Experienced engineers in well-planned organisations throughout the world solve this problem by installing BERCO/B.P.T. "On-Load" Voltage Regulating Equipment.

May we send you further information and performance details? Please write for booklet 5081.

Applications include induction heating equipment, electric furnace control, radio and scientific equipment, X-ray and electro-medical apparatus, meter testing equipment and all electric or electronic equipment for which a constant supply voltage is essential.



Single phase
"Regavolt" hand operated
voltage regulator.

**THE BRITISH ELECTRIC RESISTANCE CO. LTD.
BRITISH POWER TRANSFORMER CO. LTD.**

Queensway • Ponders End • Middlesex

Telephone: HOWard 1492

Telegrams: "Vitrohm, Enfield"



TAKE A BIRD'S EYE VIEW

OF THE No. 9A IMPULSE MACHINE

*** an impulse sender for Routers and Testers**

The illustration shows the new No. 9A impulse machine which operates with a speed and frequency accuracy of 0.5% with an input voltage range of 46 to 52 volts. It provides 12 impulses per second in trains of 9 and 11, 8 and 9, and 1 and 10 impulses with 80%, 66.6% or 50% break. The spring contacts operate without bounce. Their accuracy is visibly verifiable on graduated dials.

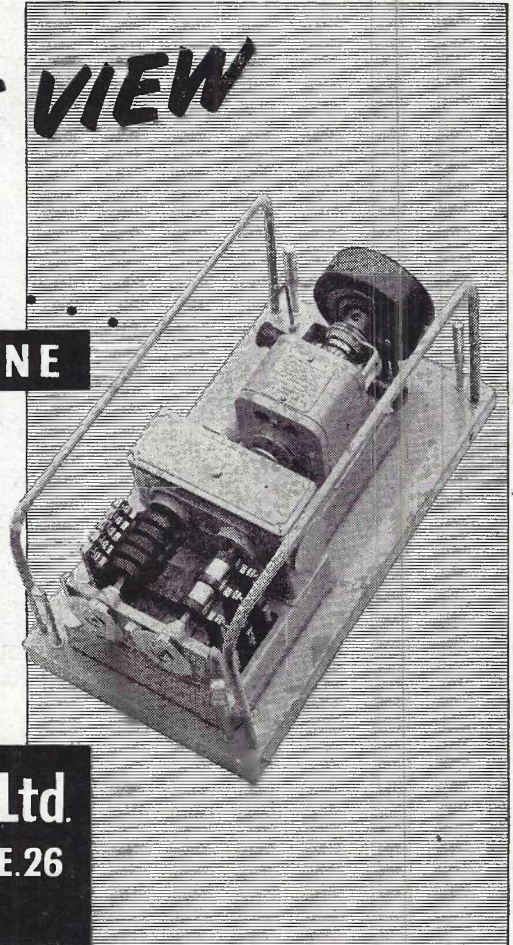

WALTER JONES & Co. (Engineers) Ltd.
NEWLANDS PARK • SYDENHAM • LONDON • S.E.26
TEL: SYDenham 6264

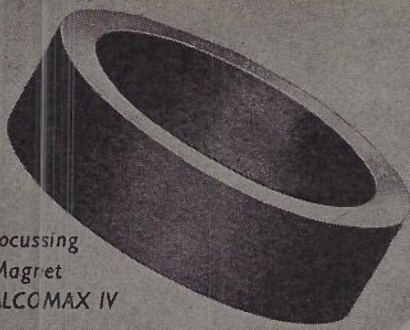

Focussing Magnet
ALCOMAX IV



Gramophone pickup Magnets
ALCOMAX III



ALCOMAX II
Loud Speaker Magnet

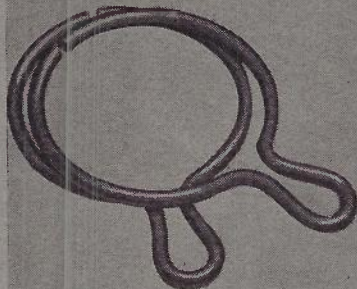

Picture Shift Magnets
in 6% Chromium Steel



Ion Trap Magnet
in 6% Chromium Steel



Ion Trap Magnet
ALNICO

Permanent Magnets for the Radio & T.V. Industry

The very latest techniques in permanent magnet manufacture can effect real economies in your production and at the same time contribute further to efficient operation of your products. Consult our Technical Staff at an early stage of design to be certain that you are taking advantage of recent progress.

Send for literature:

Pub. PM108—Loud Speaker Magnets.

Pub. PM112—Permanent Magnets for Television Receivers.



PERMANENT MAGNETS

JAMES NEILL & CO. (SHEFFIELD) LTD.,
SHEFFIELD, 11 ENGLAND
M3



MILLIVOLTMETER TYPE 784

(Wideband Amplifier and Oscilloscope Pre-Amplifier)

- Frequency range from 30 c/s to 10 Mc/s
- Voltage ranges 0-10, 0-100, 0-1000 millivolts
- Cathode follower probe
- Can be used as an amplifier up to 15 Mc/s
- Immediate delivery



THIS instrument consists essentially of a high-impedance probe unit followed by a stable wide-band amplifier and diode voltmeter. Measurements may be made from 1 millivolt to 1 volt in the frequency range 30 c/s to 10 Mc/s. The provision of a low impedance output enables the instrument to be used as a general purpose amplifier in the frequency range 30 c/s to 15 Mc/s, or as an extremely sensitive pre-amplifier for the Airmec Oscilloscope Type 723.

Full details of this or any other Airmec instrument will be forwarded gladly upon request.

AIRMEC
LIMITED

HIGH WYCOMBE

BUCKINGHAMSHIRE

ENGLAND

Telephone: High Wycombe 2060

Cables: Airmec, High Wycombe

TELEPHONE DISTRIBUTION

EQUIPMENT

ENGINEERS WHO ARE INTERESTED IN TELEPHONE DISTRIBUTION EQUIPMENT ARE INVITED TO REQUEST SECTION T.C.13 OF OUR TELECOMMUNICATION CABLES CATALOGUE.

TELEPHONE:
SOUTHAMPTON
2141 (5 lines).

IRELLI & GENERAL
CABLE WORKS, Ltd., SOUTHAMPTON

TELEGRAMS
"PIGEKAYBEL
SOUTHAMPTON"



EDISWAN

Telephone Line Protectors

Write for
your copy
TODAY

How to protect telephone lines

Surge currents, induced on telephone lines by electric storms or breakdowns on neighbouring power lines, may be effectively controlled by Ediswan telephone line protectors. These special electrode gas discharge tubes have been developed in collaboration with G.P.O. Engineers to provide economical and effective protection for telephone systems without impairing the service.

Full details of these protectors and their application is given in the new Ediswan publication C.1581 which is now available free of charge.

EDISWAN

THE EDISON SWAN ELECTRIC COMPANY, LTD.
155 CHARING CROSS ROAD, LONDON, W.C.2.

Member of the A.E.I. Group of Companies.